

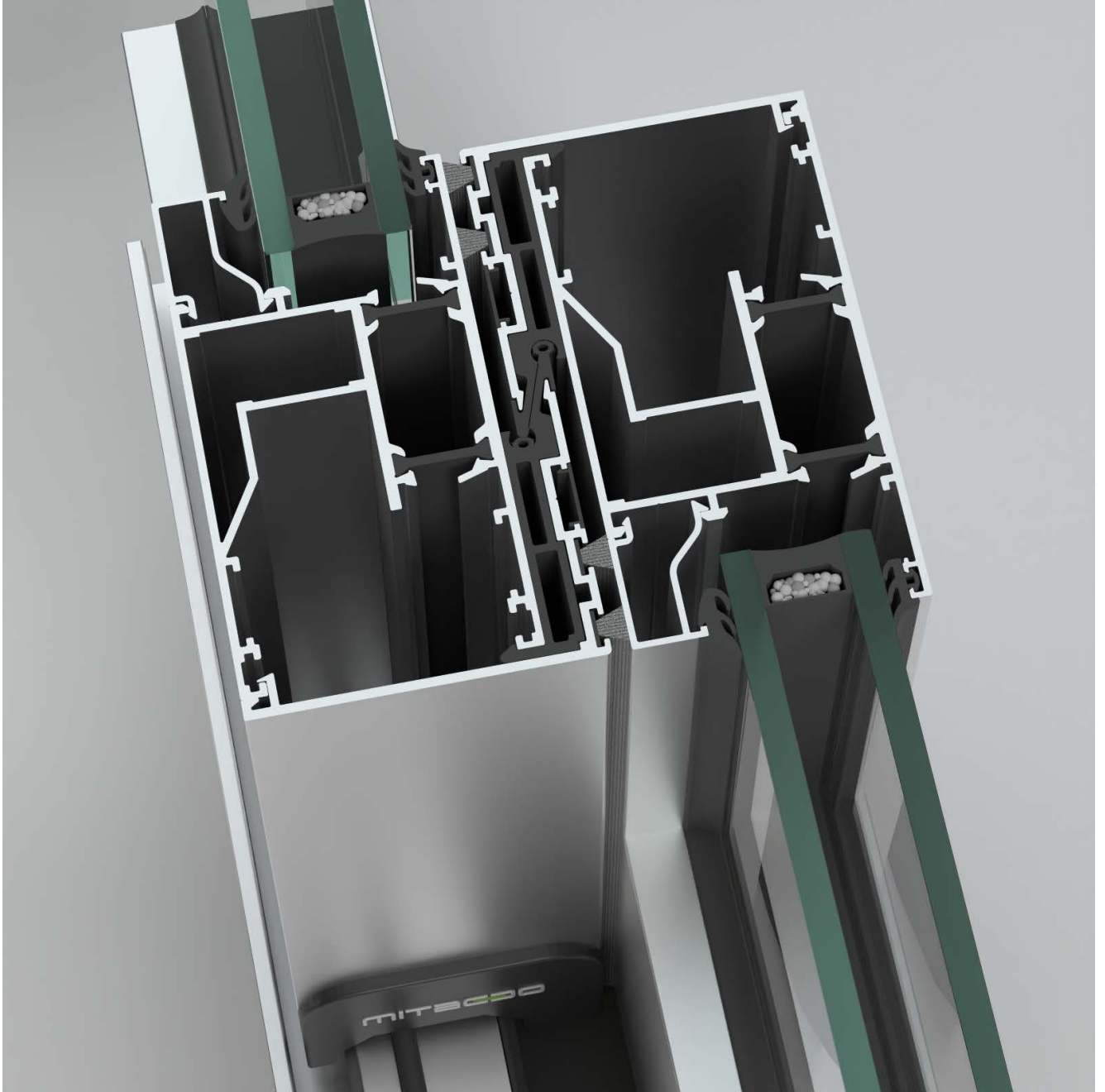

LST-125

KALDIRSUR & SÜRME SİSTEMİ

SLIDE - LIFT& SLIDE SYSTEM



GENEL BİLGİLER

GENERAL INFORMATION

KASA DERİNLİĞİ / Frame Depth	Min. 125 - Max. 133 mm
KANAT DERİNLİĞİ / Vent Depth	1,5 mm
PROFİL ET KALINLIĞI / Profile Wall Thickness	1,5 / 1,8 mm
MAKS. CAM KALINLIĞI / Max Glass Thickness	42,0 mm
YALITIM BARIYERİ / Thermal Insulation Bar	14,8 / 18 / 20 mm

KULLANIM SEÇENEKLERİ / APPLICATION ALTERNATIVE

KALDIRSÜR / Lify&Slide	EVET / YES
KLASİK SÜRME / Sliding	EVET / YES
90° KÖŞE DÖNÜŞ / 90° Corner	EVET / YES
MONO RAY KASA / Mono Rail Frame	EVET / YES
İKİ RAY KASA / Double Rail Frame	EVET / YES
ÜÇ RAY KASA / Triple Rail Frame	EVET / YES
SABİT KASA / Fixed Frame	EVET / YES
KANAT İÇTE ÇALIŞIR / Sliding Wing Indoor Operation	EVET / YES
PVC AKSESUAR / PVC Accessories	EVET / YES

PERFORMANS DEĞERLERİ / PERFORMANCE VALUES

HAVA GEÇİRGENLİĞİ / Air Permeability - EN 12207	CLASS 4 (600 Pa)
SU SIZDIRMAZLIK / Water Tightness - EN 12208	CLASS EA (1200 Pa)
RÜZGAR YÜKÜ DAYANIM / Resistance To Wind Load EN 12210	CLASS 3 (1200 Pa)
SEHİM / Deflection Criteia - EN 12210	CLASS C (L/150)
SİSTEM UF DEĞERİ / Thermal Insulation Value EN 10077-2	2,42-4,7 W/m ² K

ISI RAPORLARI

HEAT REPORTS

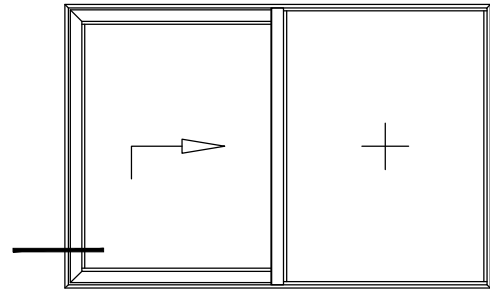

Model 1

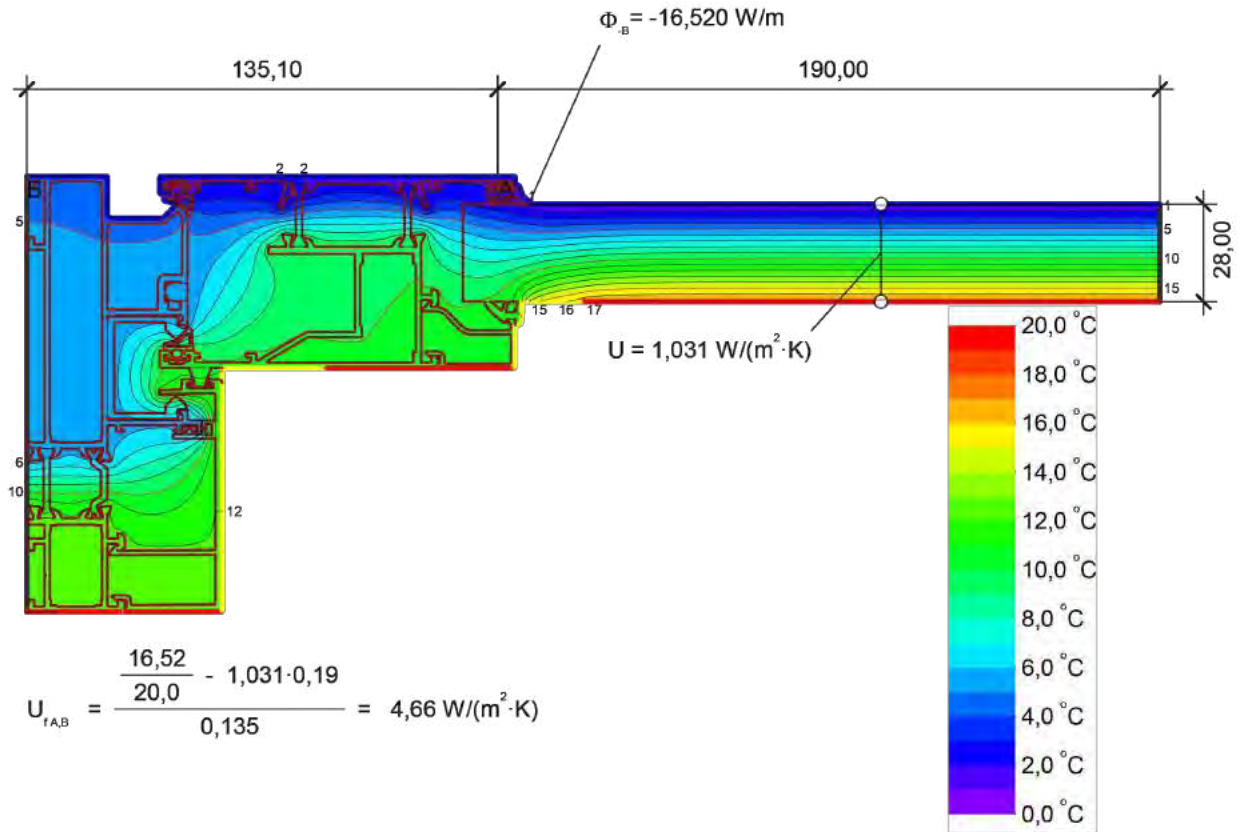

$$U_{fA,B} = \frac{\frac{16,52}{20,0} - 1,031 \cdot 0,19}{0,135} = 4,66 \text{ W}/(\text{m}^2 \cdot \text{K})$$



Material	λ [W/(m·K)]	ϵ	Boundary Condition	q [W/m ²]	θ [°C]	R [(m ² ·K)/W]	ϵ
Aluminium (Si Alloys)	160,000	0,900	n 0.9				0,900
EPDM (ethylene propylene diene monomer)	0,250	0,900	∅r, frame	0,000		0,040	
PVC-U (polyvinylchloride), rigid	0,170	0,900	∅r, frame, normal	20,000		0,130	
Panel	0,035	0,900	∅r, frame, reduced	20,000		0,200	
Polyamid 6.6 with 25% glass fibre	0,300	0,900	∅r, frame, reduced	20,000		0,200	
Polyester resin	0,190	0,900	∅r, frame, reduced	20,000		0,200	
Slightly ventilated air cavity *			∅r, frame, reduced	20,000		0,200	
Unventilated air cavity *			∅r, frame, reduced	20,000		0,200	
* EN ISO 10077-2:2017, 6.4.3/anisotrop							

Model 1

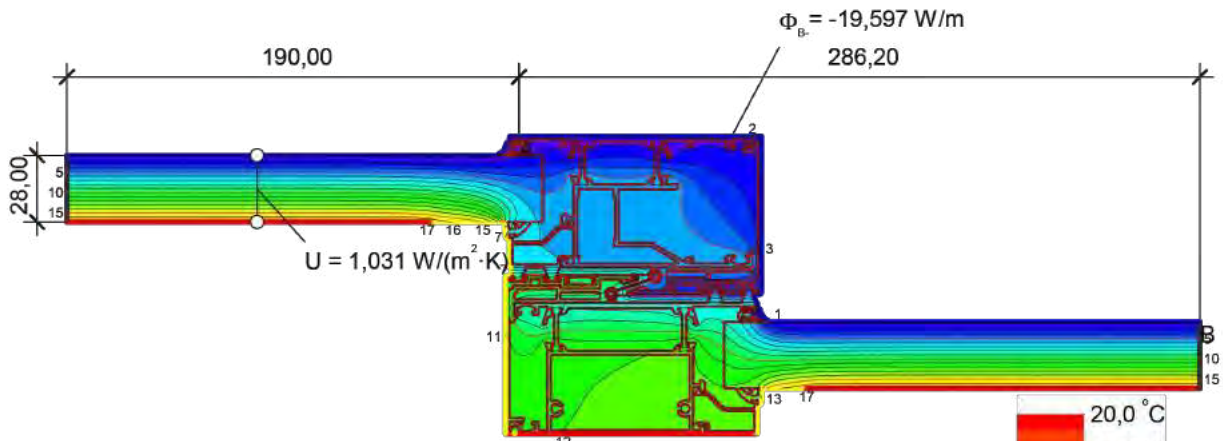
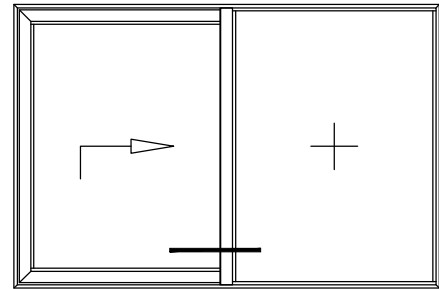

$$U_f = \frac{\frac{19,597}{20,0} - 1,031 \cdot 0,19}{0,286} = 2,74 \text{ W/(m}^2 \cdot \text{K)}$$

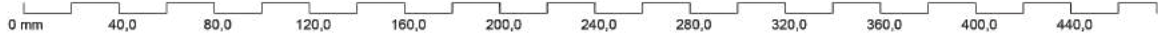

Material	λ [W/(m·K)]	ϵ	Boundary Condition	q [W/m ²]	θ [°C]	R [(m ² ·K)/W]	ϵ
Aluminium (Si Alloys)	160,000	0,900	n 0.9				0,900
EPDM (ethylene propylene diene monomer)	0,250	0,900	∅r, frame	0,000		0,040	
PVC-U (polyvinylchloride), rigid	0,170	0,900	∅r, frame, normal	20,000		0,130	
Panel	0,035	0,900	∅r, frame, reduced	20,000		0,200	
Polyamid 6.6 with 25% glass fibre	0,300	0,900	∅etry/Model section	0,000			
Polyester resin	0,190	0,900					
Unventilated air cavity *							

* EN ISO 10077-2:2017, 6.4.3/anisotrop

Model 1

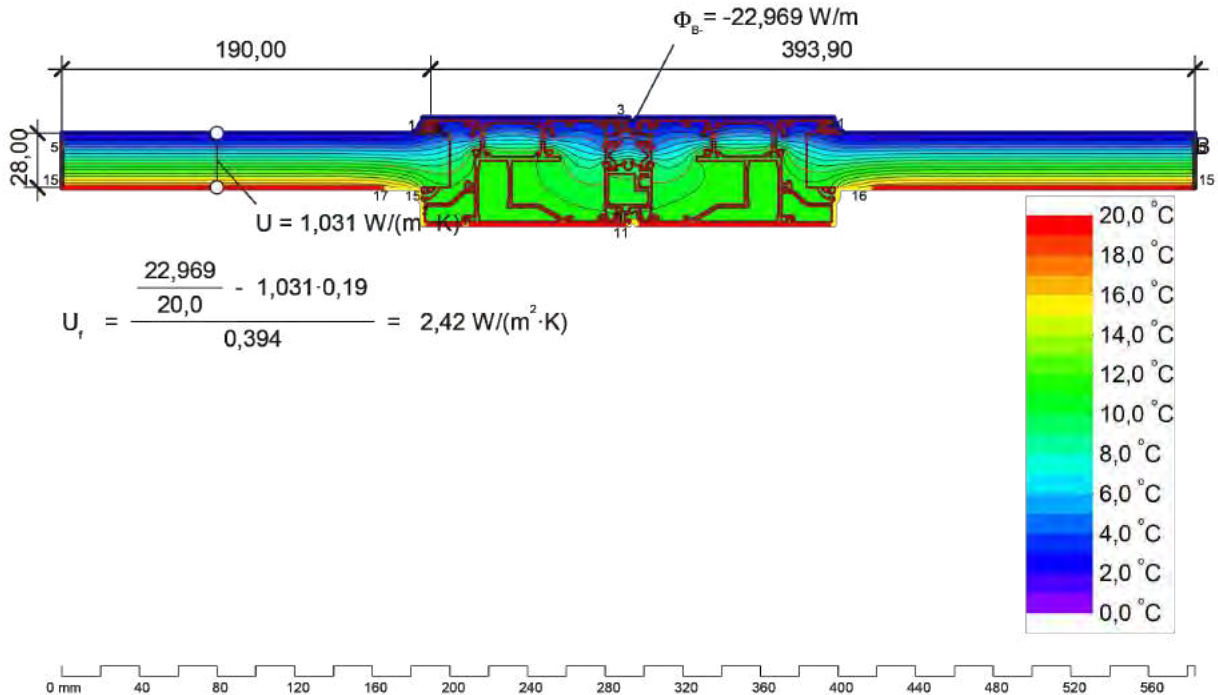
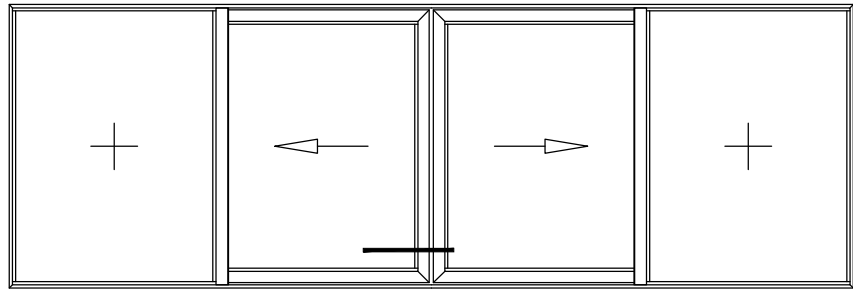

Material	λ [W/(m·K)]	ϵ	Boundary Condition	q [W/m ²]	θ [°C]	R [(m ² ·K)/W]	ϵ
Aluminium (Si Alloys)	160,000	0,900	n 0.9				0,900
EPDM (ethylene propylene diene monomer)	0,250	0,900	∅r, frame	0,000		0,040	
Panel	0,035	0,900	∅r, frame, normal	20,000		0,130	
Polyamid 6.6 with 25% glass fibre	0,300	0,900	∅r, frame, reduced	20,000		0,200	
Polyester resin	0,190	0,900	∅etry/Model section	0,000			
Unventilated air cavity *							
* EN ISO 10077-2:2017, 6.4.3/anisotrop							

PROFILLER

PROFILES

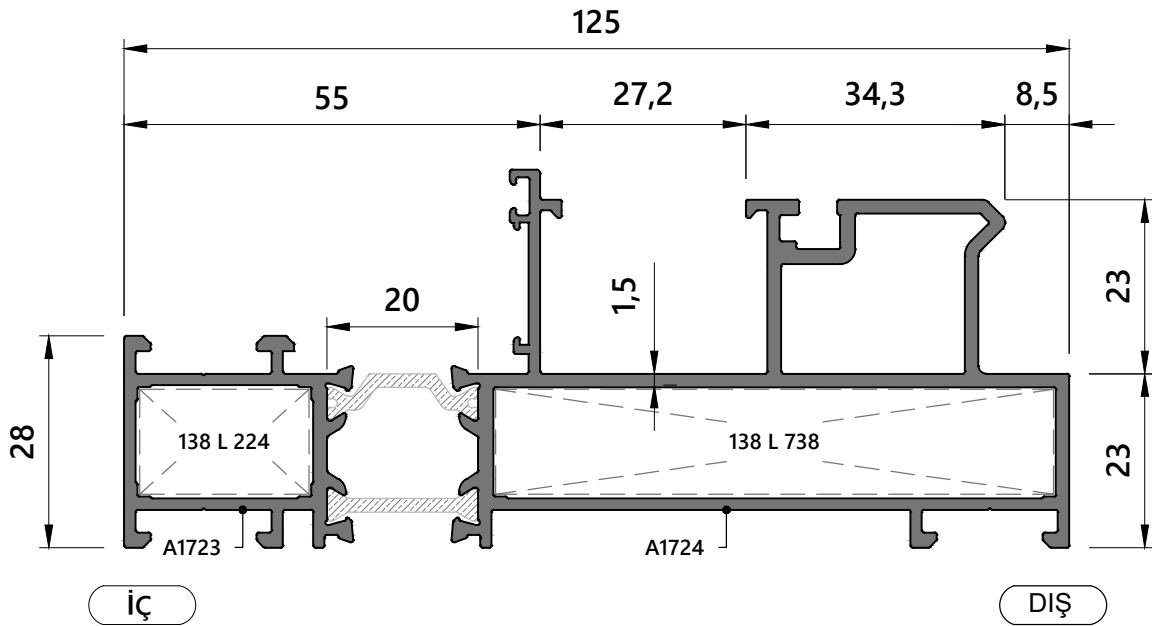

FT12501 Kasa Profil / Frame Profile		
kg/m	Jx	Jy
2,277	13,70	117,35

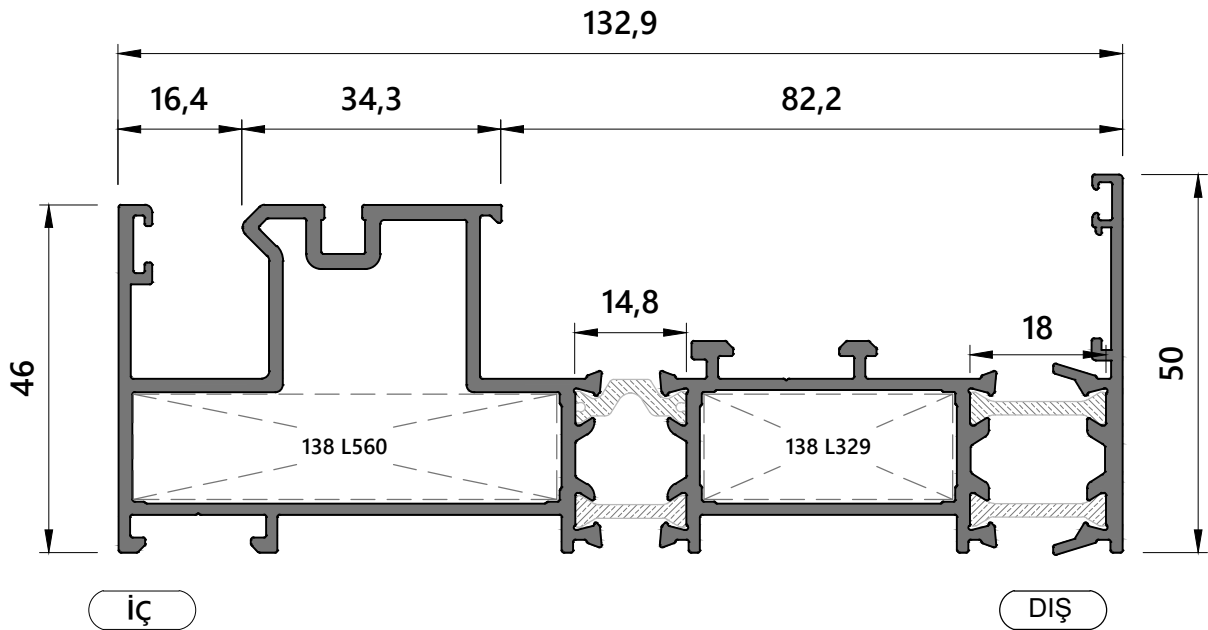

FT12510 Kasa Profil / Frame Profile		
kg/m	Jx	Jy
2,625	17,16	171,17

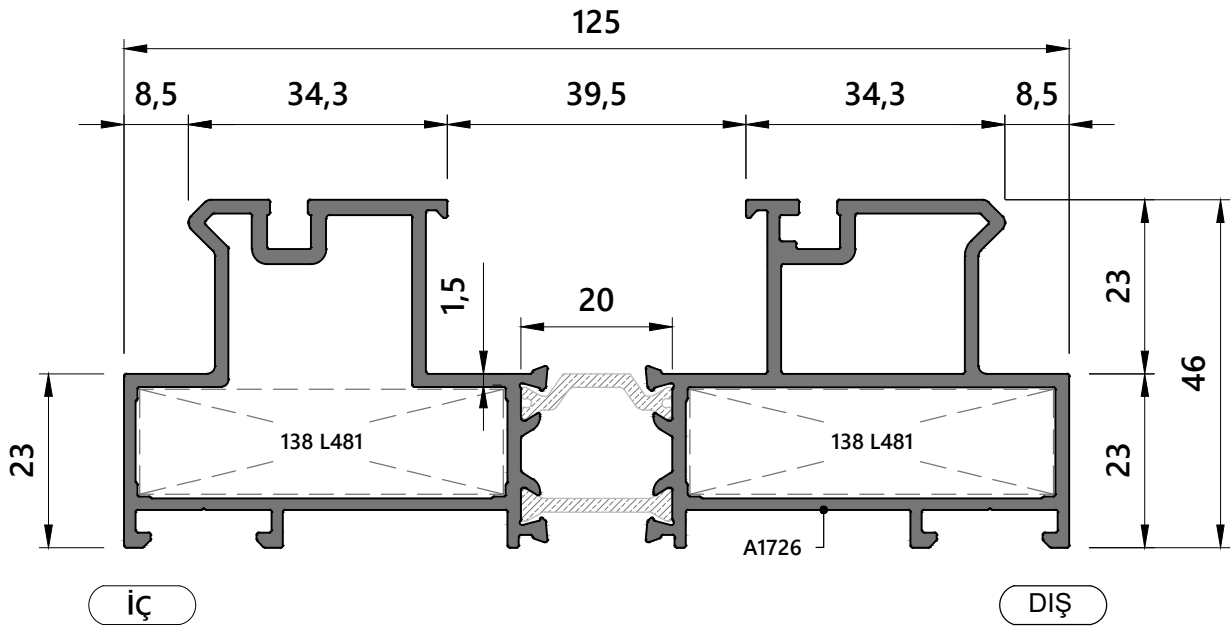

FT12502 Kasa Profil / Frame Profile		
kg/m	Jx	Jy
2,357	18,42	124,34

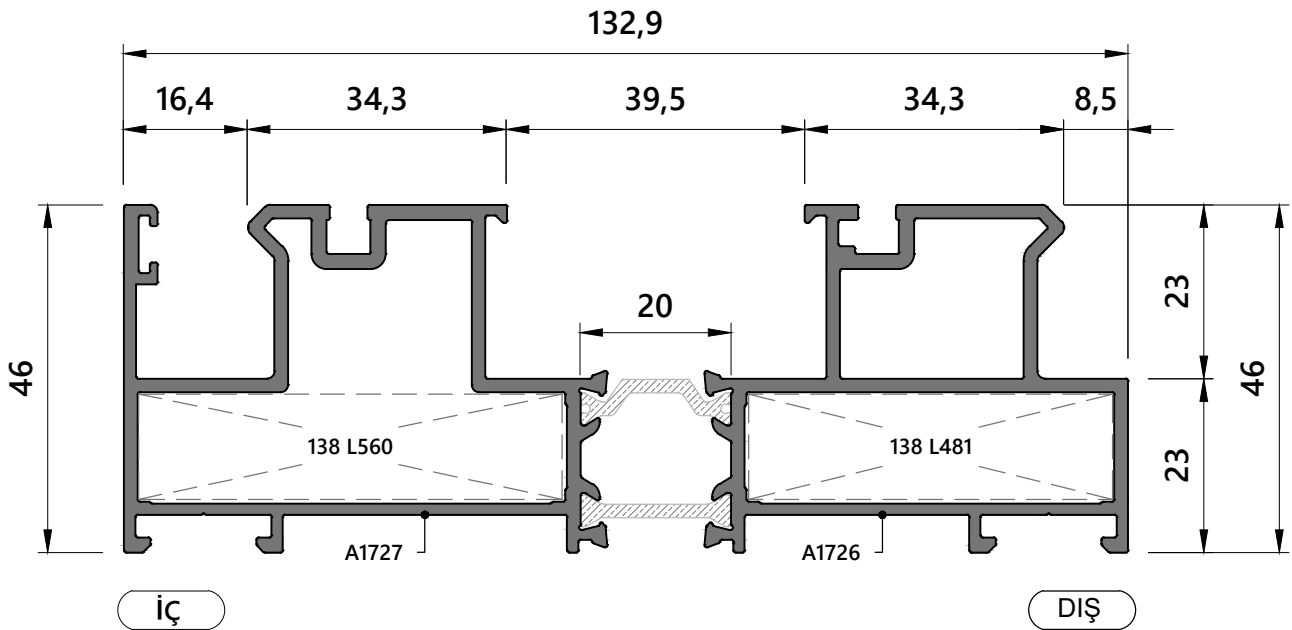

FT12512 Kasa Profil / Frame Profile		
kg/m	Jx	Jy
2,636	20,09	167,58

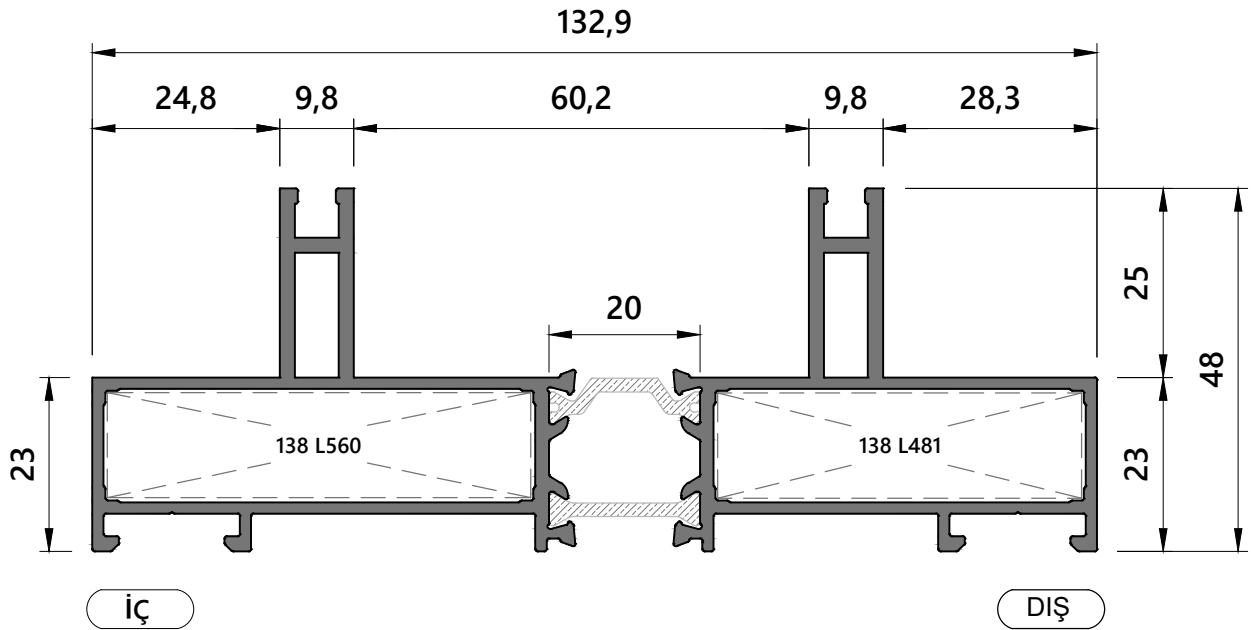

FT12522 Kasa Profil / Frame Profile		
kg/m	Jx	Jy
2,302	123,00	13,67

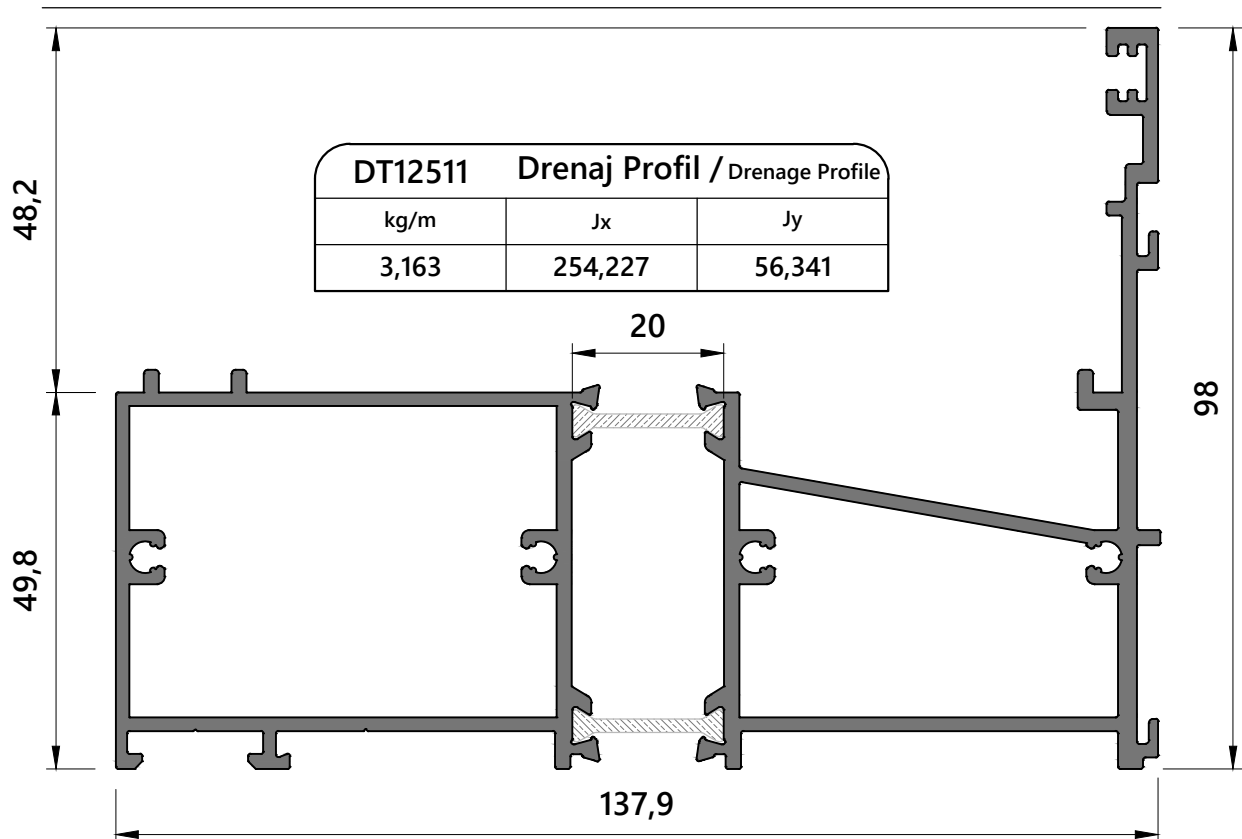

DT12511 Drenaj Profil / Drainage Profile		
kg/m	Jx	Jy
3,163	254,227	56,341

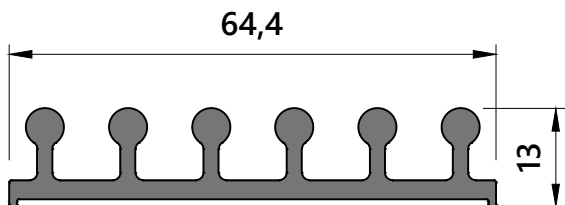

D12512 Drenaj Profil / Drainage Profile		
kg/m	Jx	Jy
0,918	-	-

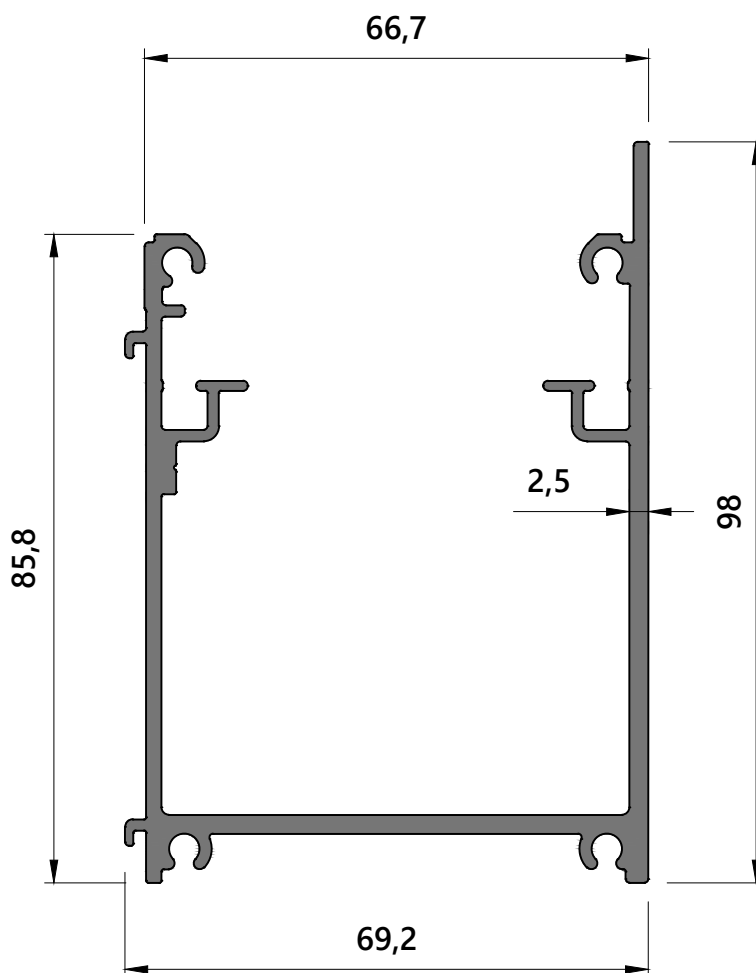

D12513 Drenaj Profil / Drainage Profile		
kg/m	Jx	Jy
1,971	-	-

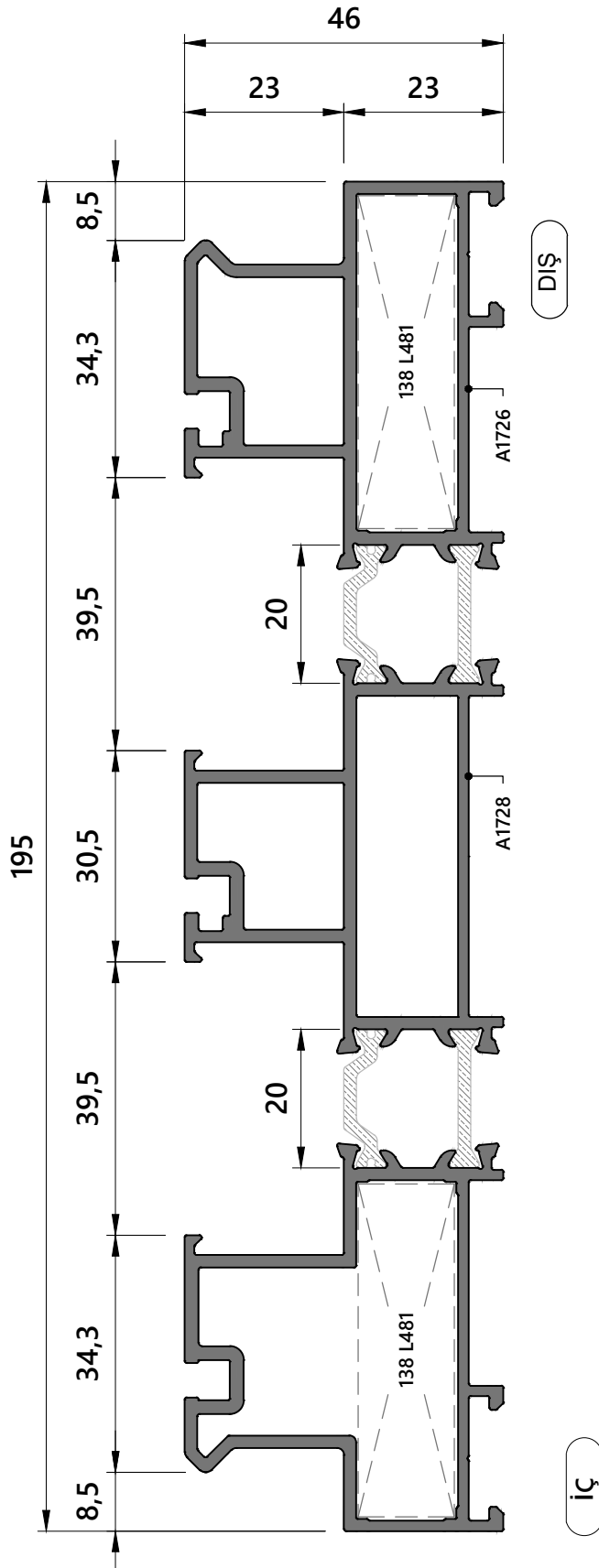

FT12503		Kasa Profil / Frame Profile	
kg/m	Jx	Jy	
3,646	27,19	449,61	

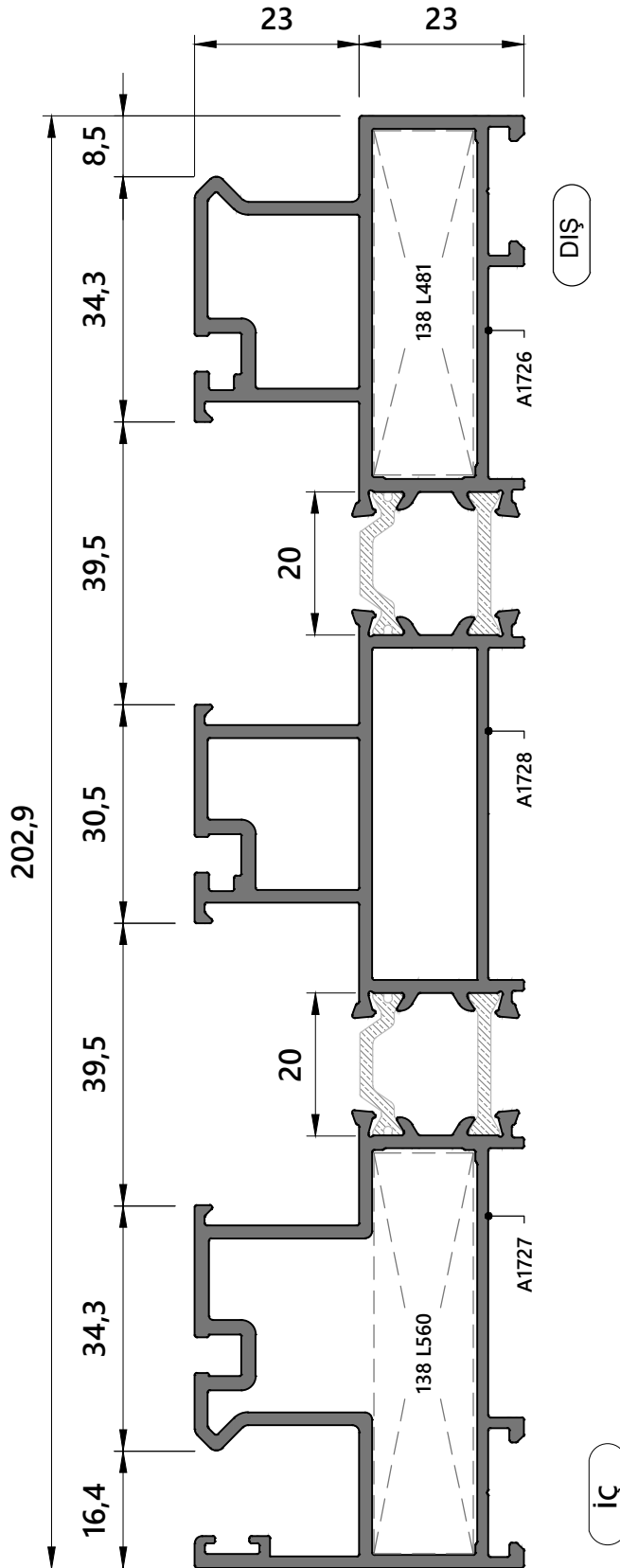

FT12513		Kasa Profil / Frame Profile	
kg/m	Jx	Jy	
3,864	28,63	538,99	

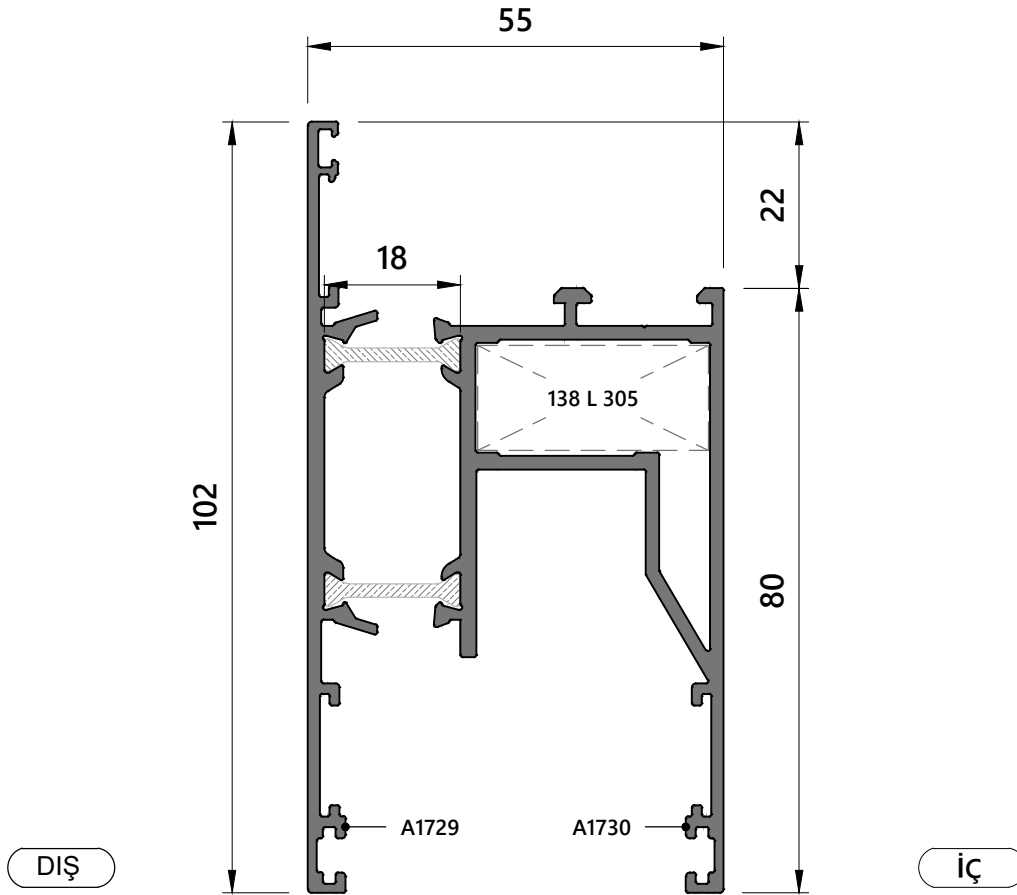

VT12501 Kanat Profili / Vent Profile		
kg/m	Jx	Jy
2,111	41,63	30,00

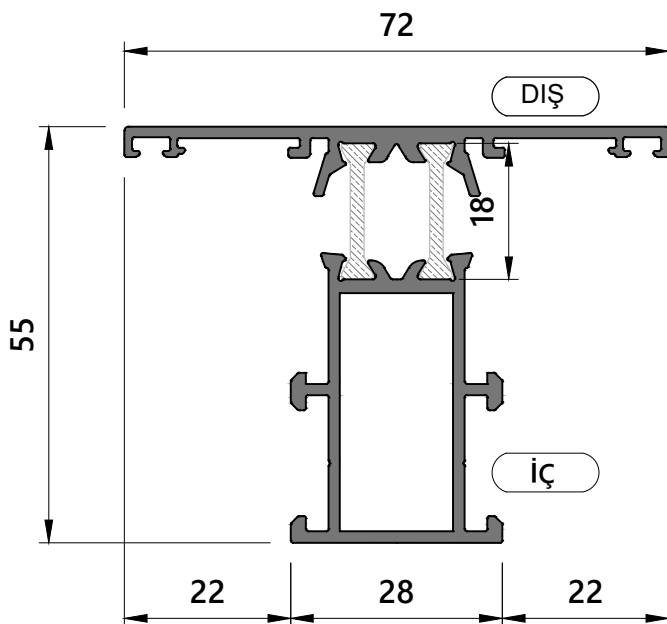

MT12501 Orta Kayıt / Mullion Profile		
kg/m	Jx	Jy
1,323	15,96	8,08

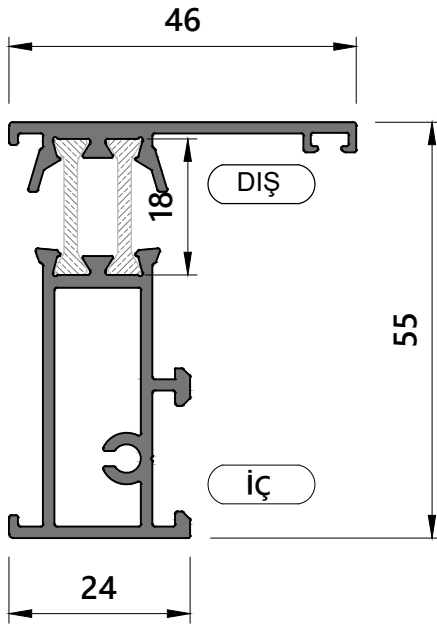

VT12511 Minimal Kanat / Vent Pr.		
kg/m	Jx	Jy
1,116	13,28	29,65

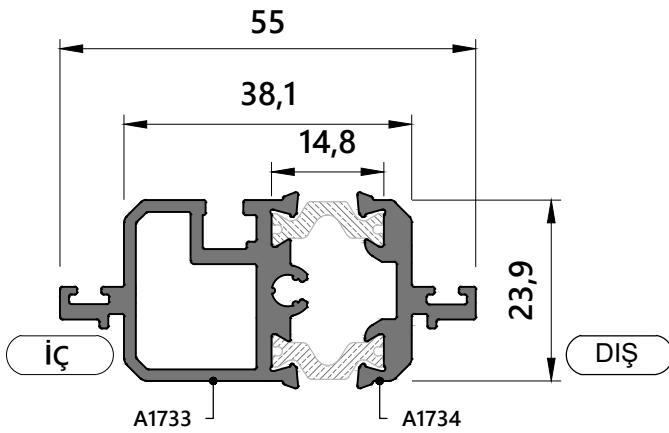

AT12501 Adaptör / Adapter Profile		
kg/m	Jx	Jy
1,046	-	-

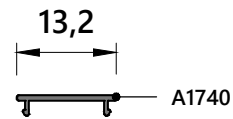
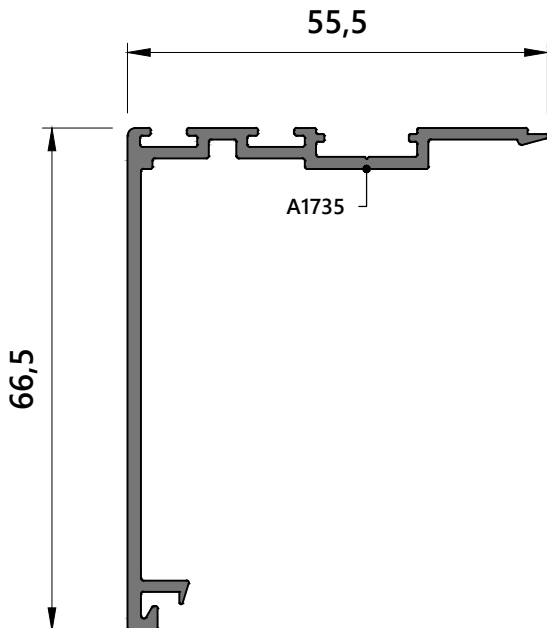

D12503	
Vida Kapak Pr.	
0,0311 kg/m	

C12501 Kenet Pr. / Adapter Profile		
kg/m	Jx	Jy
0,659	-	-

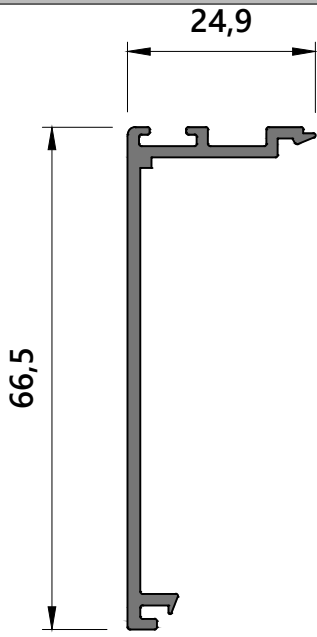

C12502		Kenet Pr. / Adapter Pr.	
kg/m	Jx	Jy	
0,457	-	-	

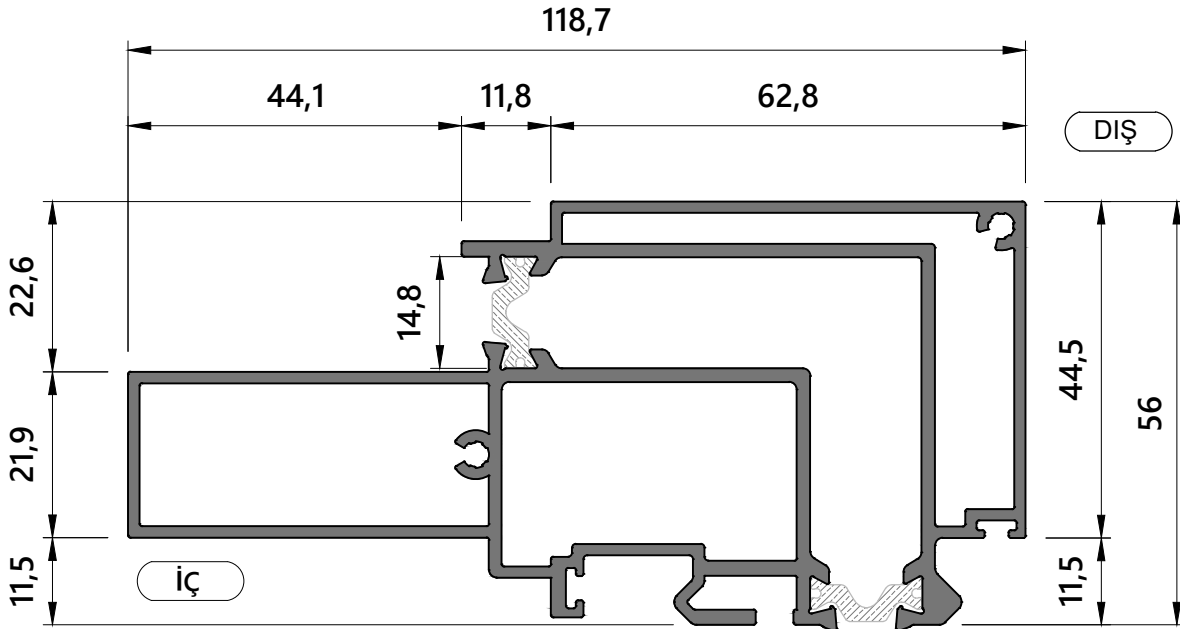

CT12501		90°DÖNÜŞ / Corner Profile	
kg/m	Jx	Jy	
2,693	-	-	

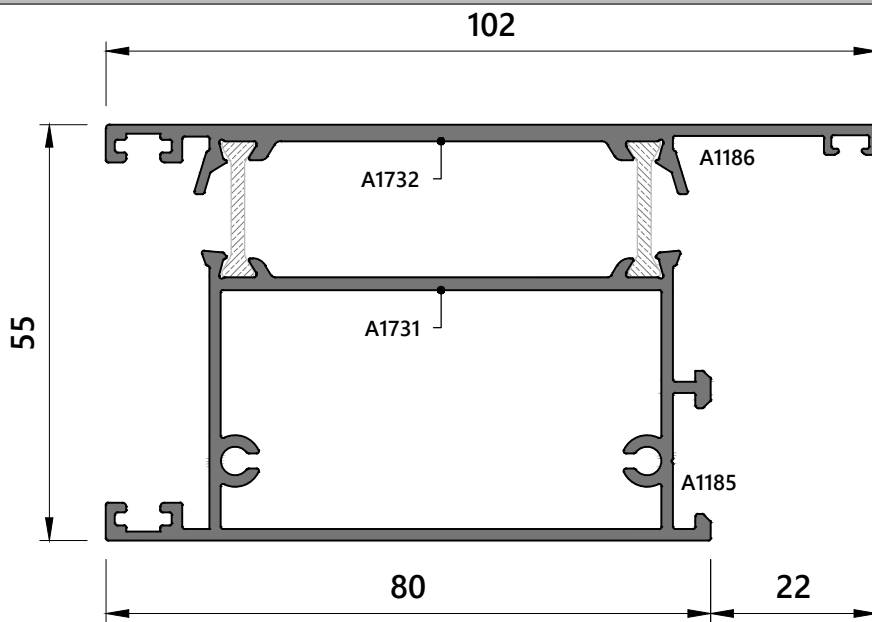

MT12502 Orta Kayıt / Transom Profile		
kg/m	Jx	Jy
1,998	49,18	28,21

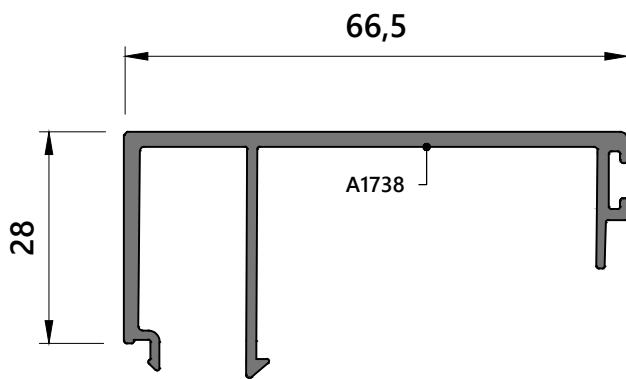

A12501 Adaptör / Adapter Profile		
kg/m	Jx	Jy
0,679	-	-

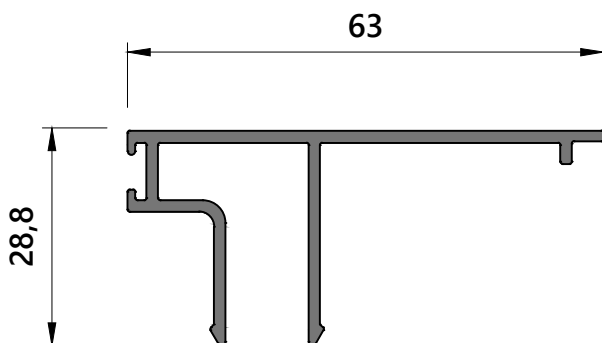

A12502 Adaptör / Adapter Profile		
kg/m	Jx	Jy
0,582	-	-

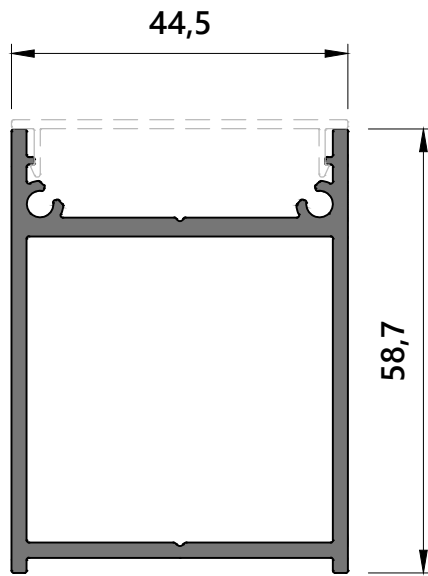

D12501 Takviye Pr. / Adapter Pr.		
kg/m	Jx	Jy
1,171	15,73	13,63

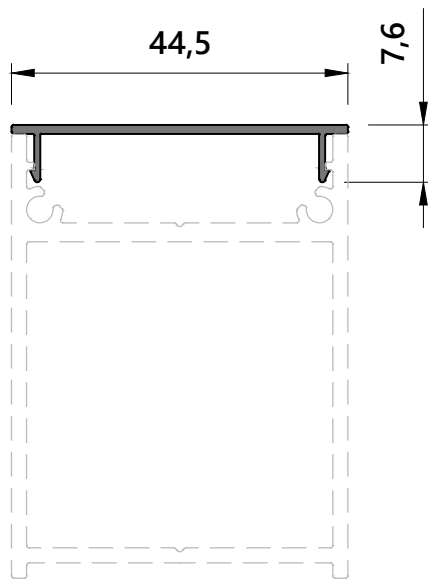

D12502 Kapak Pr. / Cap Profile		
kg/m	Jx	Jy
0,173	-	-

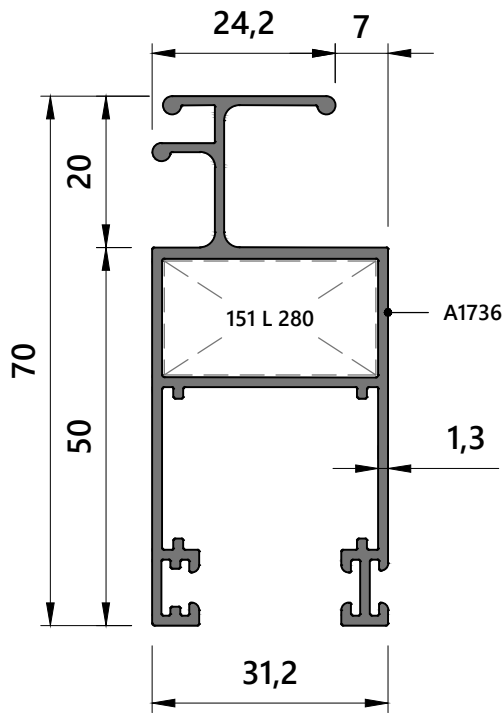

S12501
Sin.Kanat Pr.
0,884 kg/m

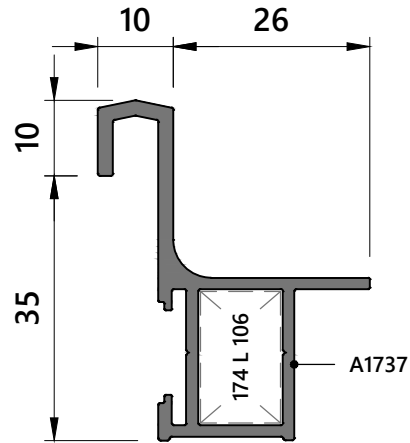

S12502
Sin.Kasa Pr.
0,590 kg/m

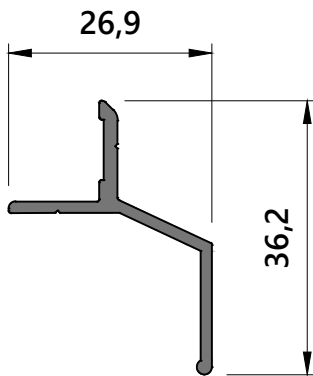

P12501
Damlalık Prof.
0,248 kg/m

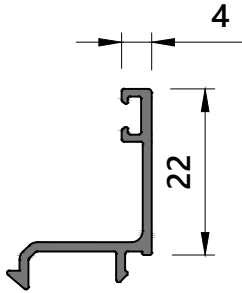

22 G 04
Cam Çıta Pr.
0,178 kg/m

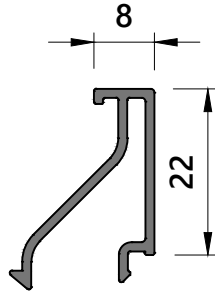

22 G 08
Cam Çıta Pr.
0,222 kg/m

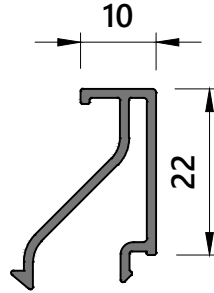

22 G 10
Cam Çıta Pr.
0,228 kg/m

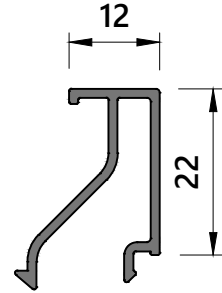

22 G 12
Cam Çıta Pr.
0,232 kg/m

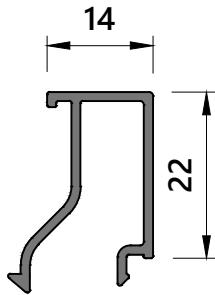

22 G 14
Cam Çıta Pr.
0,233 kg/m

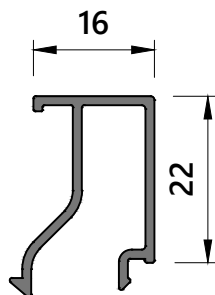

22 G 16
Cam Çıta Pr.
0,239 kg/m

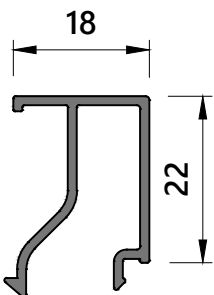

22 G 18
Cam Çıta Pr.
0,246 kg/m

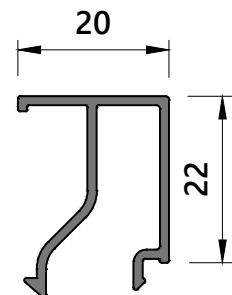

22 G 20
Cam Çıta Pr.
0,253 kg/m

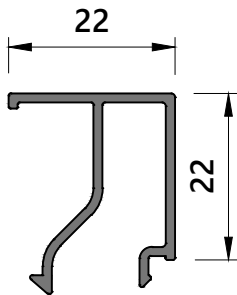

22 G 22
Cam Çıta Pr.
0,233 kg/m

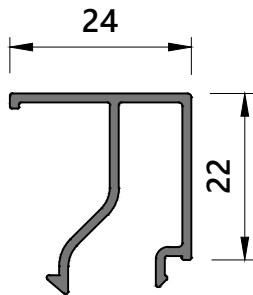

22 G 24
Cam Çıta Pr.
0,266 kg/m

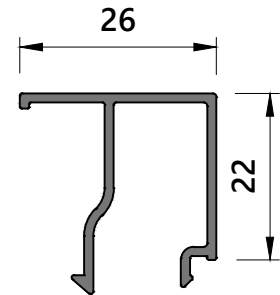

22 G 26
Cam Çıta Pr.
0,267 kg/m

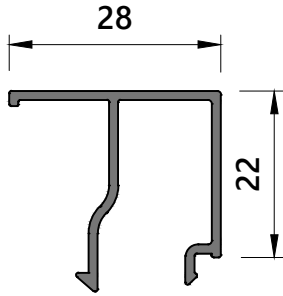

22 G 28
Cam Çıta Pr.
0,274 kg/m

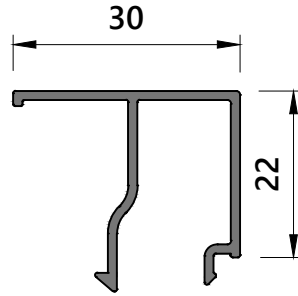

22 G 30
Cam Çıta Pr.
0,280 kg/m

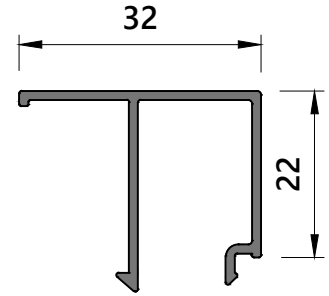

22 G 32
Cam Çıta Pr.
0,284 kg/m

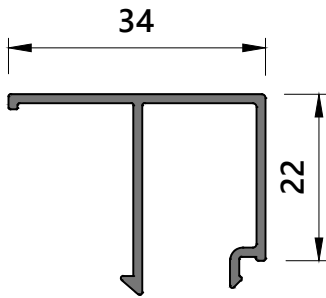

22 G 34
Cam Çıta Pr.
0,290 kg/m

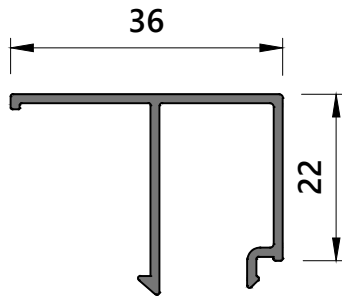

22 G 36
Cam Çıta Pr.
0,297 kg/m

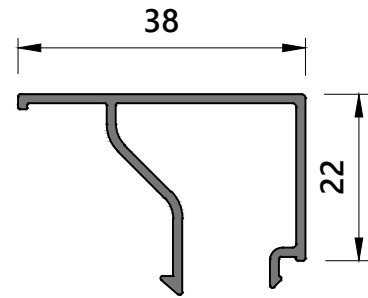

22 G 38
Cam Çıta Pr.
0,314 kg/m

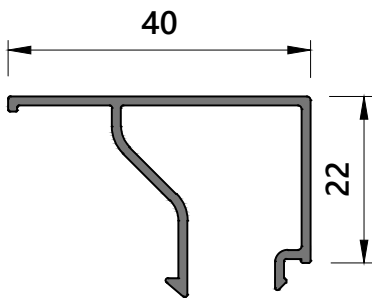

22 G 40
Cam Çıta Pr.
0,320 kg/m

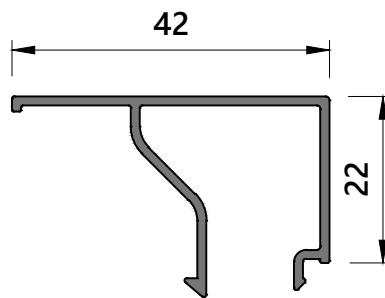

22 G 42
Cam Çıta Pr.
0,327 kg/m

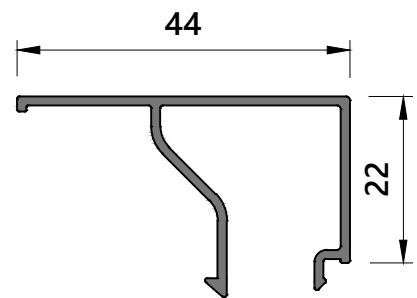

22 G 44
Cam Çıta Pr.
0,334 kg/m

CAM LİSTELERİ

GLEASING LIST

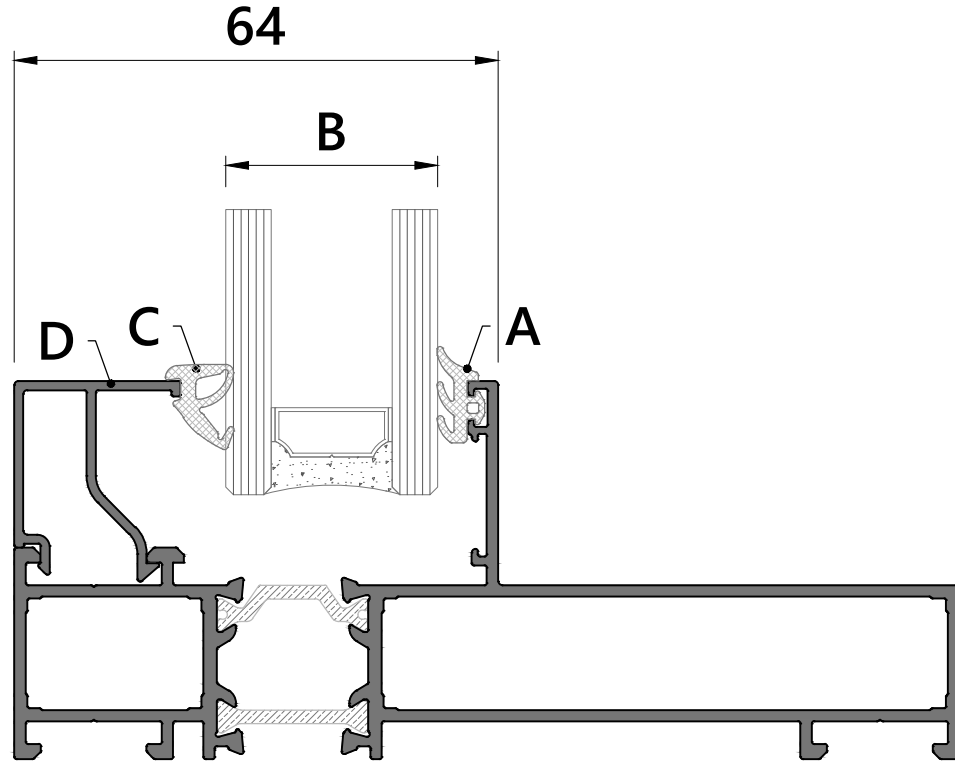

CAM KALINLIĞINA GÖRE CAM ÇİTASI SEÇİM TABLOSU
SELECTIONS TABLE ACCORDING TO GLAZING BEAD THICKNESS

A 4 mm	CAM KALINLIĞI GLASS THICKNESS B	C				D
		EP02.01 2-3 mm	EP02.02 4-5 mm	EP02.03 6-7 mm	EP02.04 8-9 mm	
EP01.01	4 mm				●	22G44
	5 mm				●	22G44
	6 mm			●		22G44
	8 mm		●			22G44
	10 mm			●		22G40
	12 mm		●			22G40
	14 mm	●				22G40
	16 mm			●		22G34
	18 mm		●			22G34
	20 mm	●				22G34
	22 mm			●		22G28
	24 mm		●			22G28
	26 mm	●				22G28
	28 mm			●		22G22
	30 mm		●			22G22
	32 mm	●				22G22
	34 mm			●		22G16
	36 mm		●			22G16
	38 mm	●				22G16
	40 mm			●		22G10
42 mm		●			22G10	

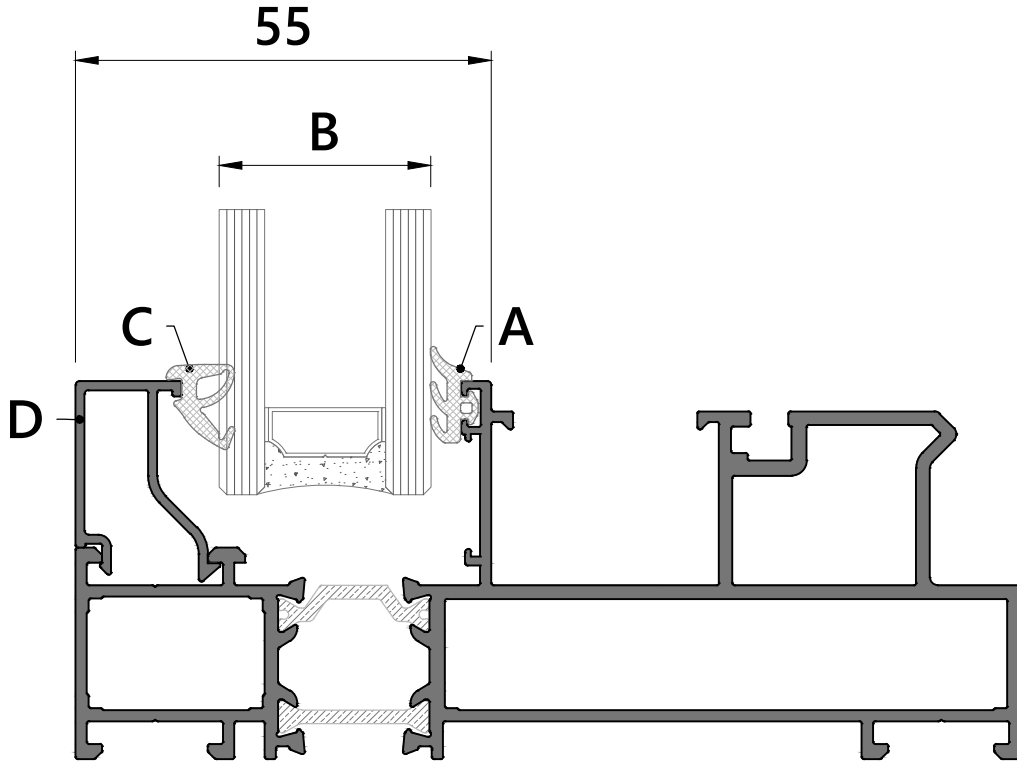

CAM KALINLIĞINA GÖRE CAM ÇITASI SEÇİM TABLOSU
SELECTIONS TABLE ACCORDING TO GLAZING BEAD THICKNESS

A 4 mm	CAM KALINLIĞI GLASS THICKNESS B	C				D
		EP02.01 2-3 mm	EP02.02 4-5 mm	EP02.03 6-7 mm	EP02.04 8-9 mm	
EP01.01	4 mm			●		22G38
	5 mm			●		22G36
	6 mm		●			22G36
	8 mm	●				22G36
	10 mm			●		22G30
	12 mm		●			22G30
	14 mm	●				22G30
	16 mm			●		22G24
	18 mm		●			22G24
	20 mm	●				22G24
	22 mm		●			22G20
	24 mm	●				22G20
	26 mm		●			22G16
	28 mm			●		22G14
	30 mm		●			22G12
	32 mm	●				22G12
	34 mm		●			22G08
	36 mm	●				22G08
38 mm			●		22G04	
40 mm	●				22G04	

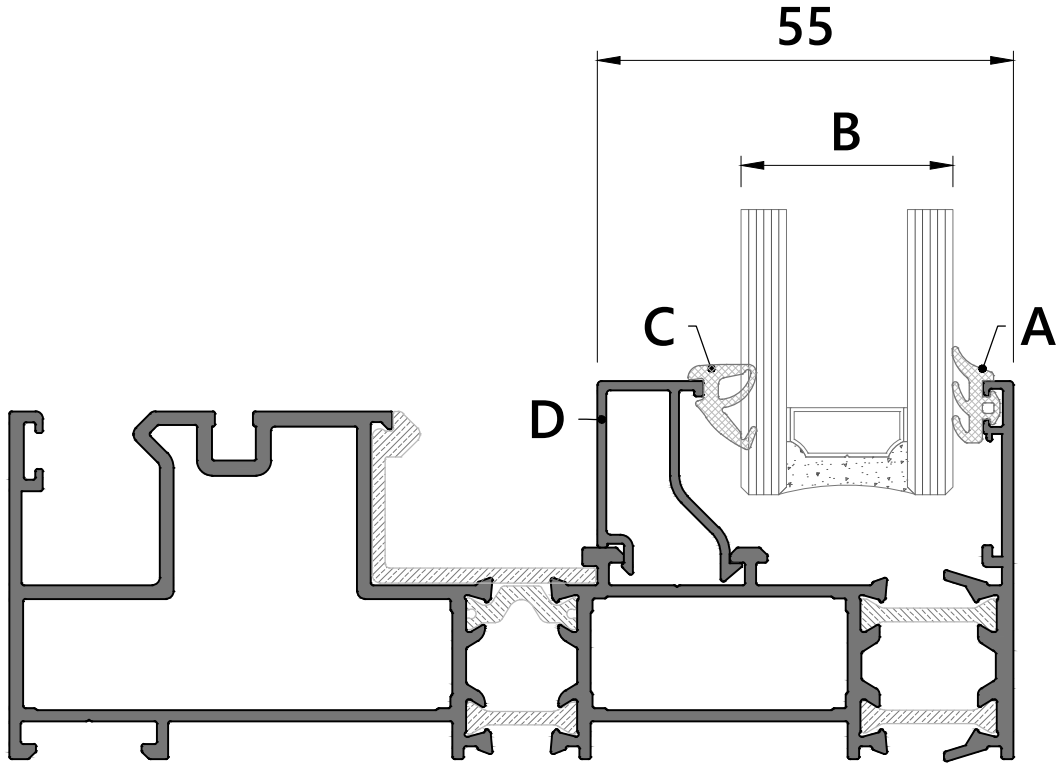

CAM KALINLIĞINA GÖRE CAM ÇITASI SEÇİM TABLOSU
SELECTIONS TABLE ACCORDING TO GLAZING BEAD THICKNESS

A 4 mm	CAM KALINLIĞI GLASS THICKNESS B	C				D
		EP02.01 2-3 mm	EP02.02 4-5 mm	EP02.03 6-7 mm	EP02.04 8-9 mm	
EP01.01	4 mm			●		22G38
	5 mm			●		22G36
	6 mm		●			22G36
	8 mm	●				22G36
	10 mm			●		22G30
	12 mm		●			22G30
	14 mm	●				22G30
	16 mm			●		22G24
	18 mm		●			22G24
	20 mm	●				22G24
	22 mm		●			22G20
	24 mm	●				22G20
	26 mm		●			22G16
	28 mm			●		22G14
	30 mm		●			22G12
	32 mm	●				22G12
	34 mm		●			22G08
	36 mm	●				22G08
38 mm			●		22G04	
40 mm	●				22G04	

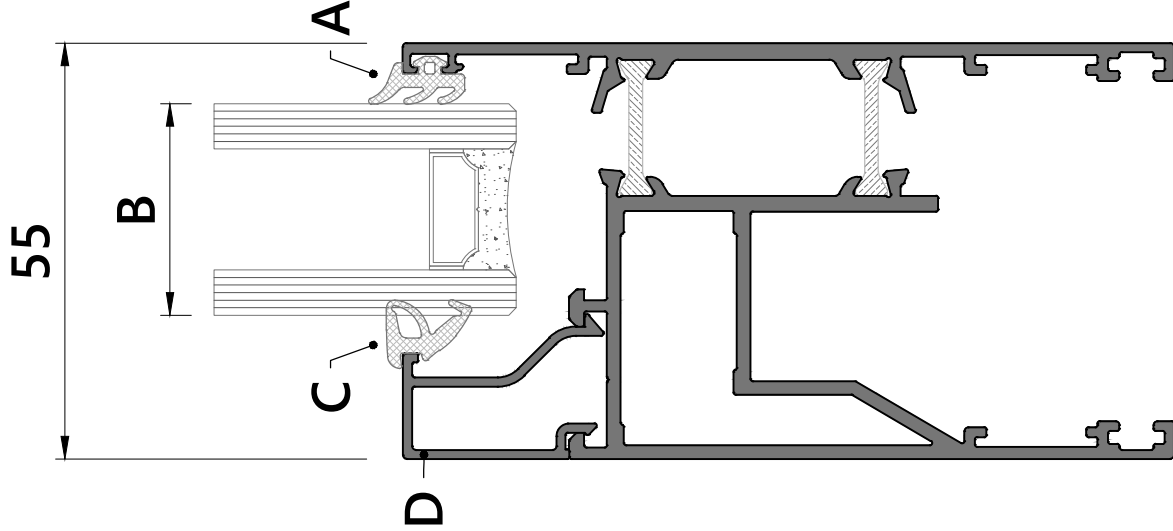

CAM KALINLIĞINA GÖRE CAM ÇITASI SEÇİM TABLOSU
SELECTIONS TABLE ACCORDING TO GLAZING BEAD THICKNESS

A 4 mm	CAM KALINLIĞI GLASS THICKNESS B	EP02.01	EP02.02	EP02.03	EP02.04	D
		2-3 mm	4-5 mm	6-7 mm	8-9 mm	
EP01.01	4 mm			●		22G38
	5 mm			●		22G36
	6 mm		●			22G36
	8 mm	●				22G36
	10 mm			●		22G30
	12 mm		●			22G30
	14 mm	●				22G30
	16 mm			●		22G24
	18 mm		●			22G24
	20 mm	●				22G24
	22 mm		●			22G20
	24 mm	●				22G20
	26 mm		●			22G16
	28 mm			●		22G14
	30 mm		●			22G12
	32 mm	●				22G12
	34 mm		●			22G08
	36 mm	●				22G08
38 mm			●		22G04	
40 mm	●				22G04	

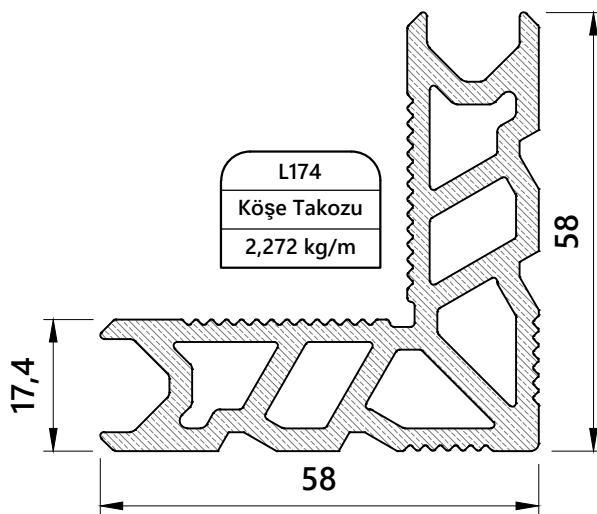
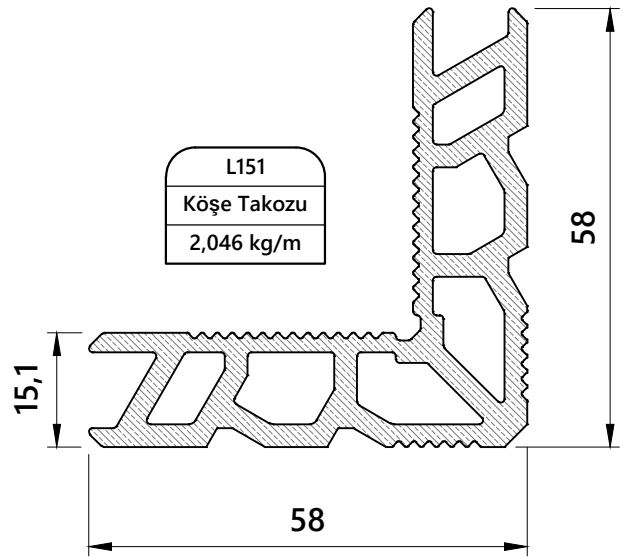
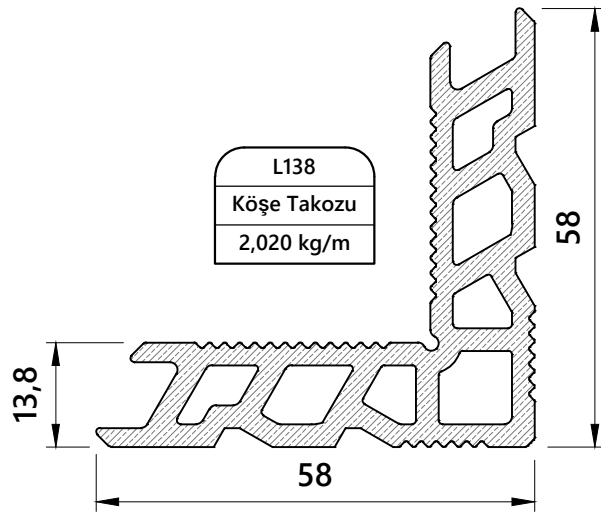

TEK RAYLI KASA UYGULAMA DETAYLARI

MONORAIL FRAME APPLICATION DETAILS

KALDIRSÜR AÇILIM TİPLERİ

LIFT&SLIDE TYPES OF OPENING

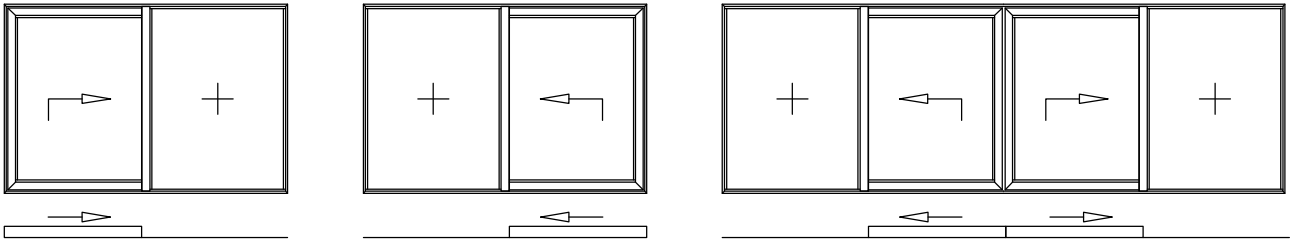

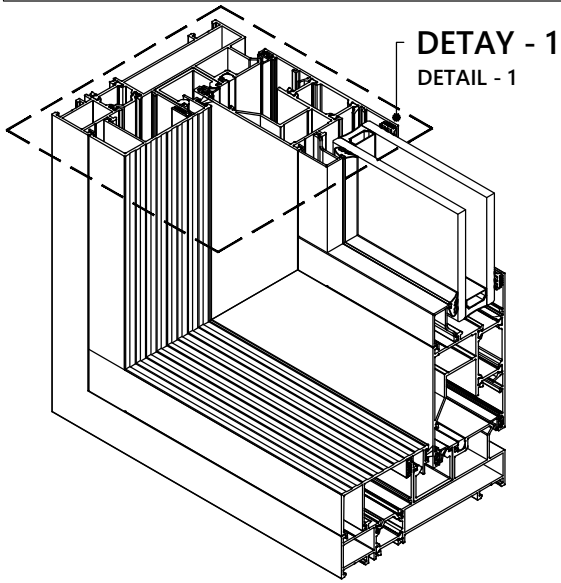

DETAY - 1
DETAIL - 1

DETAY - 1
DETAIL - 1

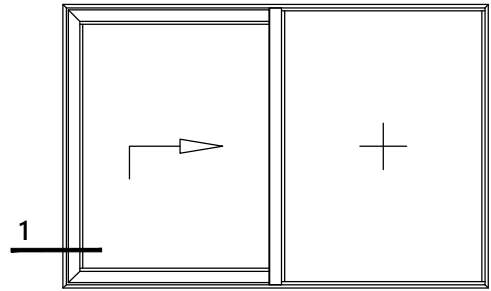

ÖLÇEK : 1/1
Scale : 1/1

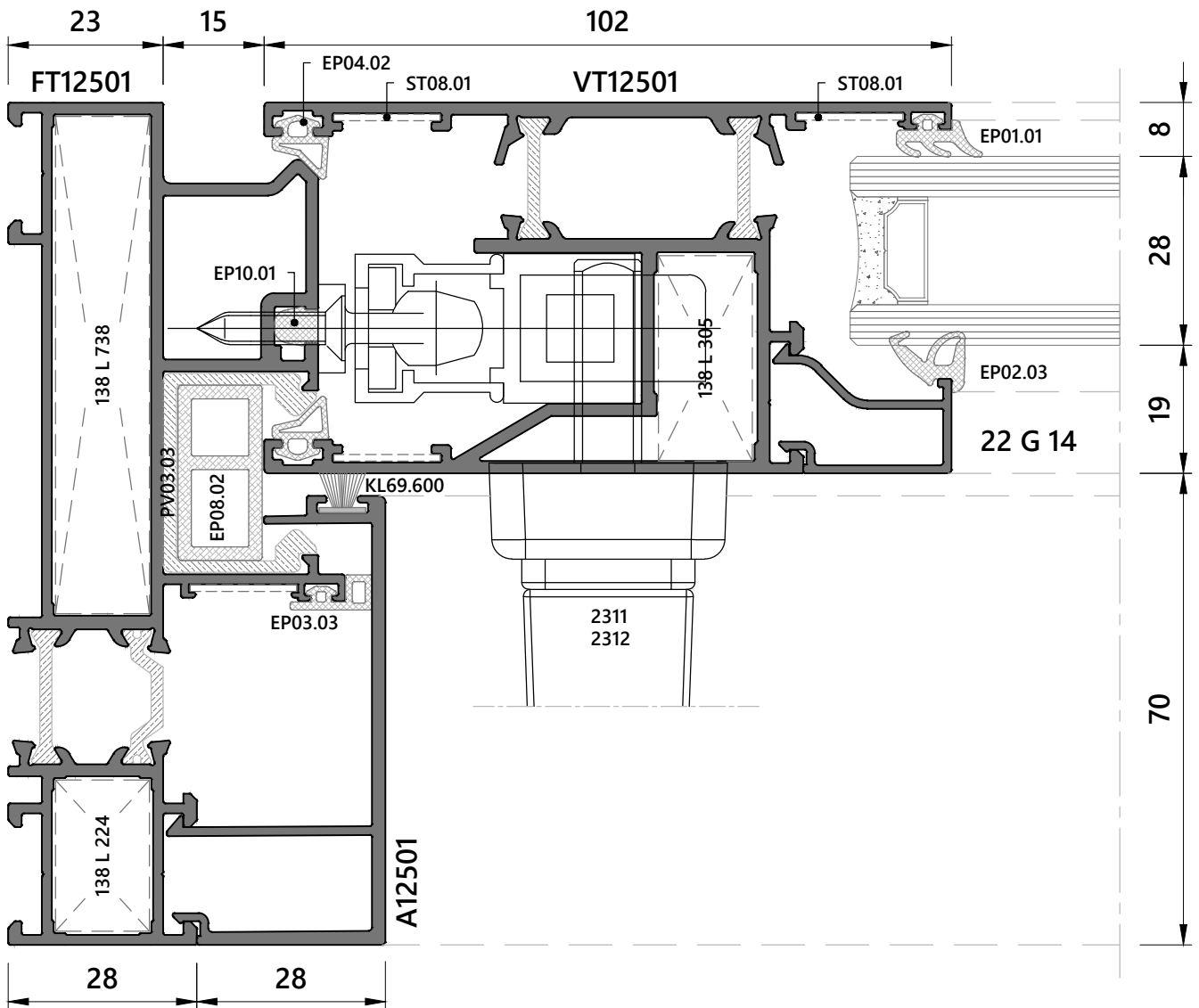

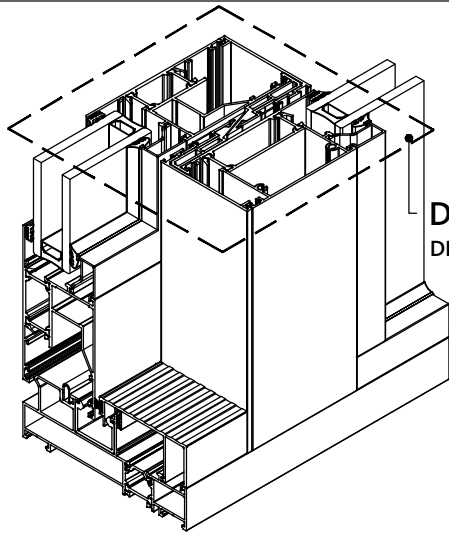

DETAY - 2
DETAIL - 2

DETAY - 2
DETAIL - 2

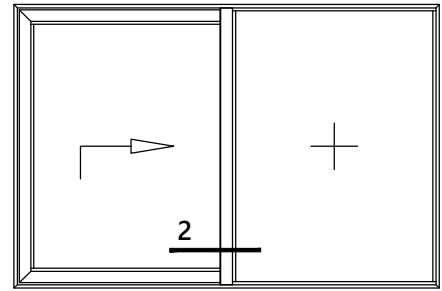

ÖLÇEK : 1/1
Scale : 1/1

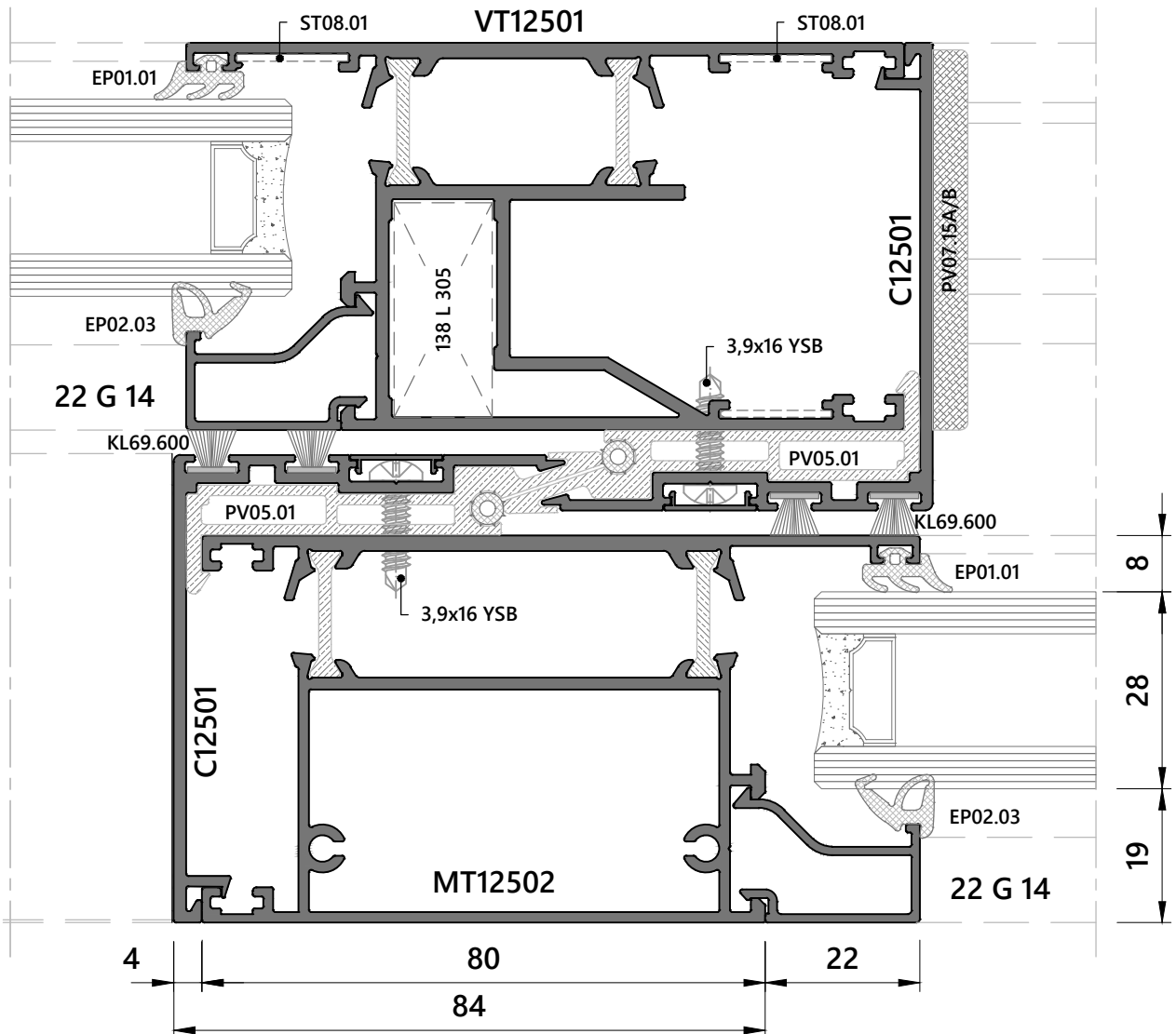

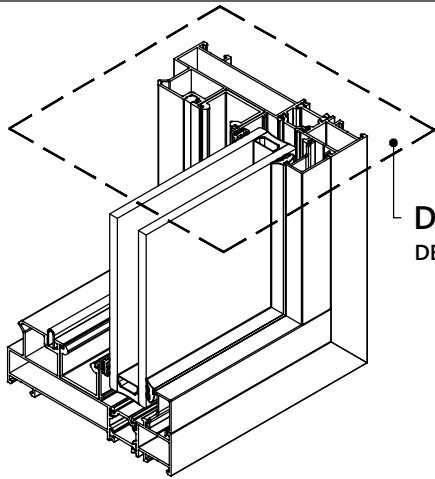

DETAY - 3
DETAIL - 3

DETAY - 3
DETAIL - 3

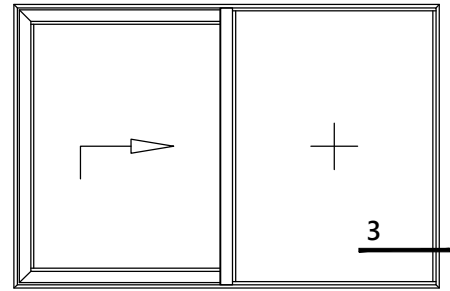

ÖLÇEK : 1/1
Scale : 1/1

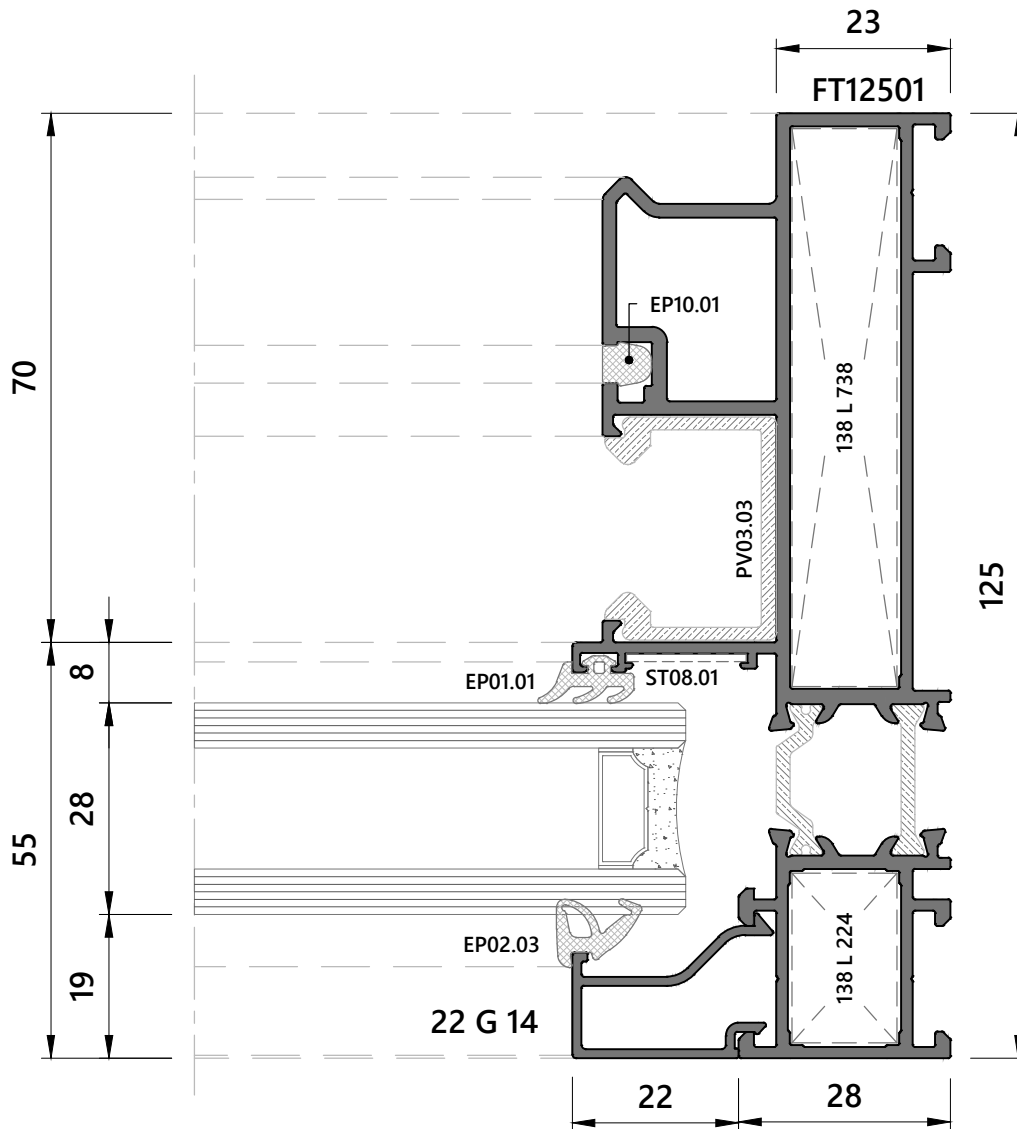

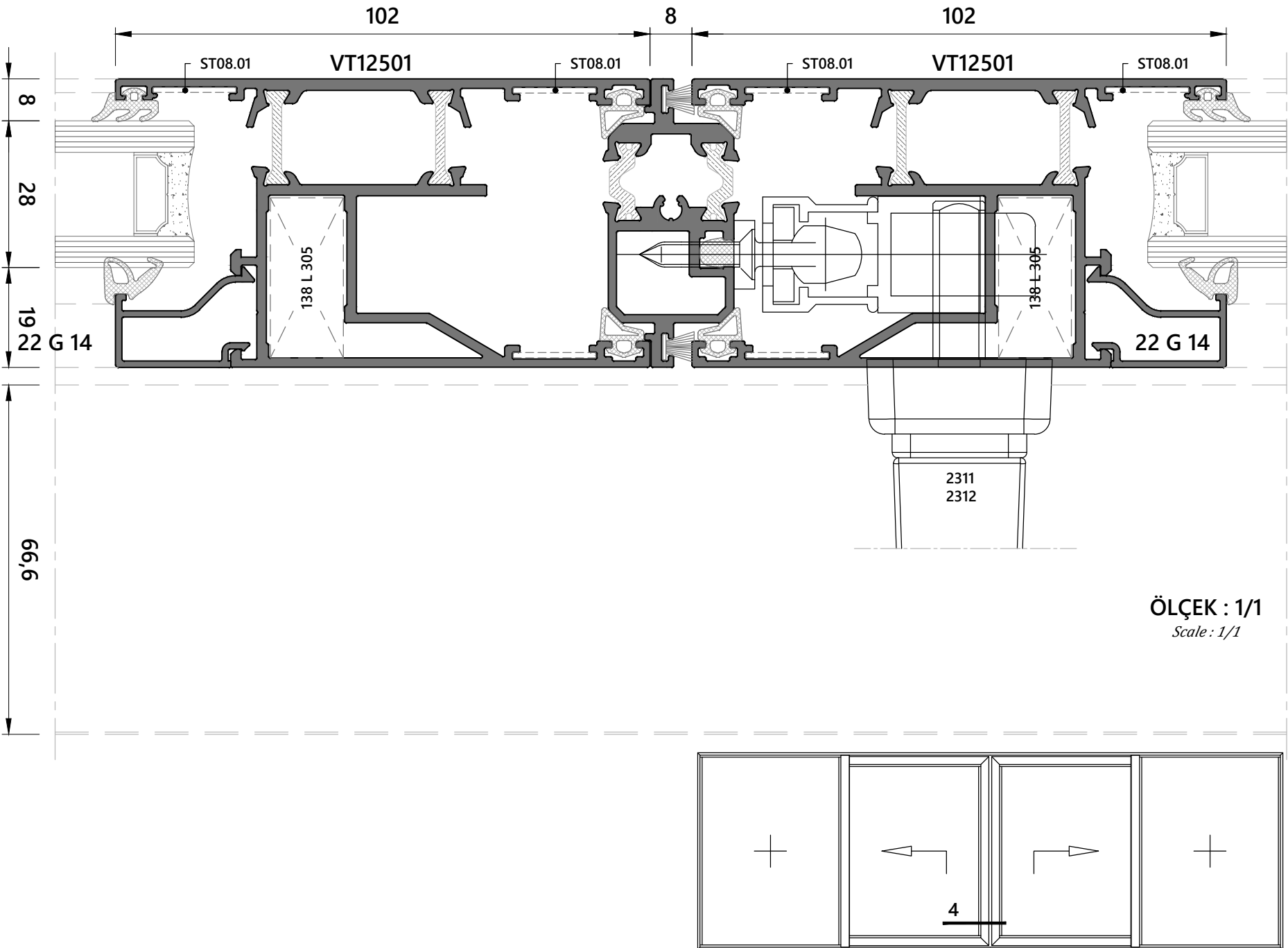

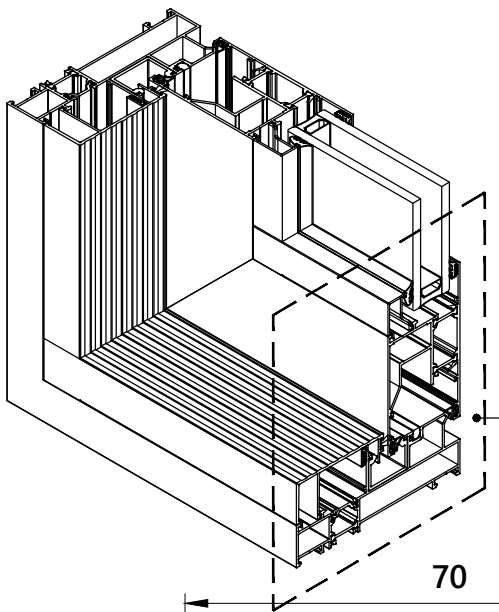

DETAY - 5
DETAIL - 5

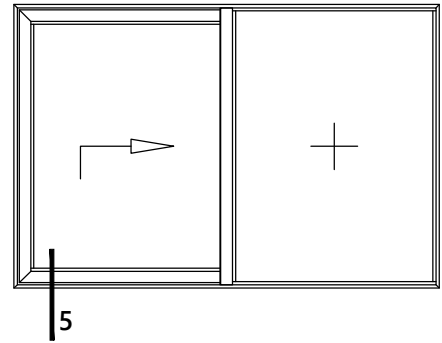

ÖLÇEK : 1/1
Scale : 1/1

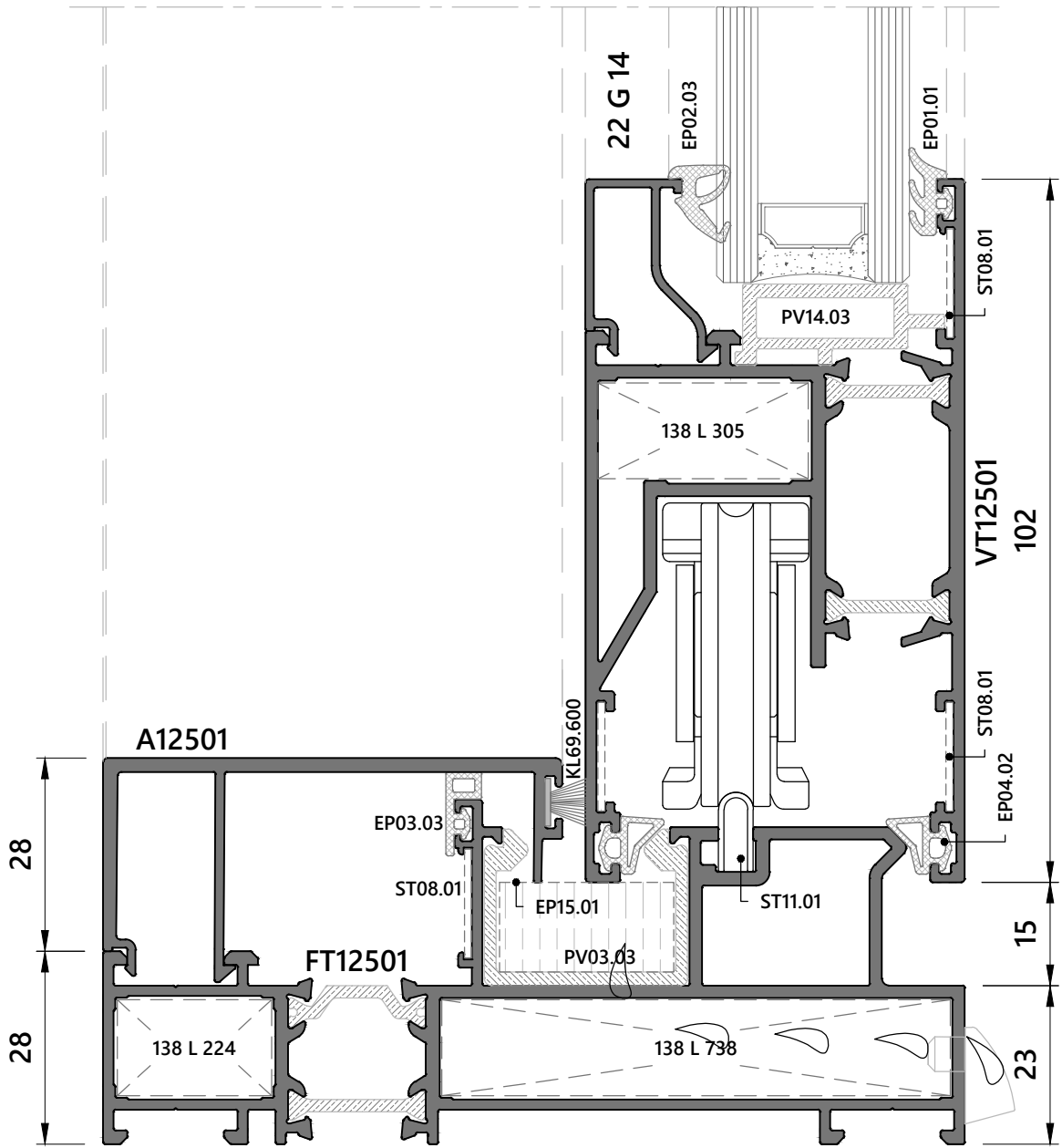
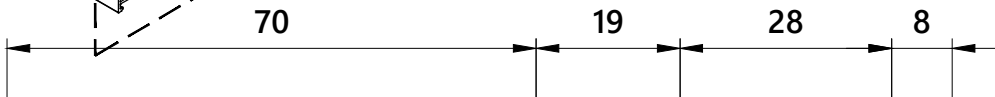

DETAY - 6
DETAIL - 6

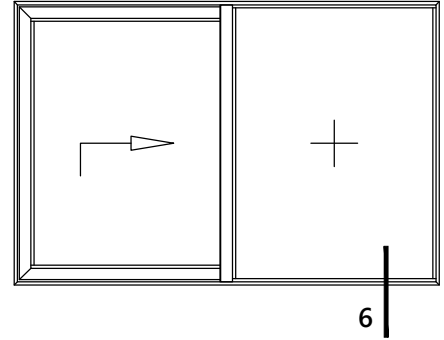
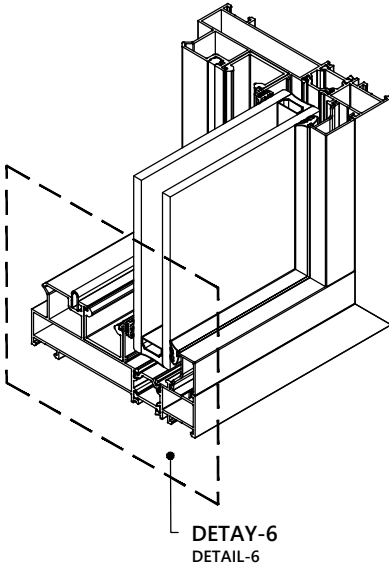

ÖLÇEK : 1/1
Scale : 1/1

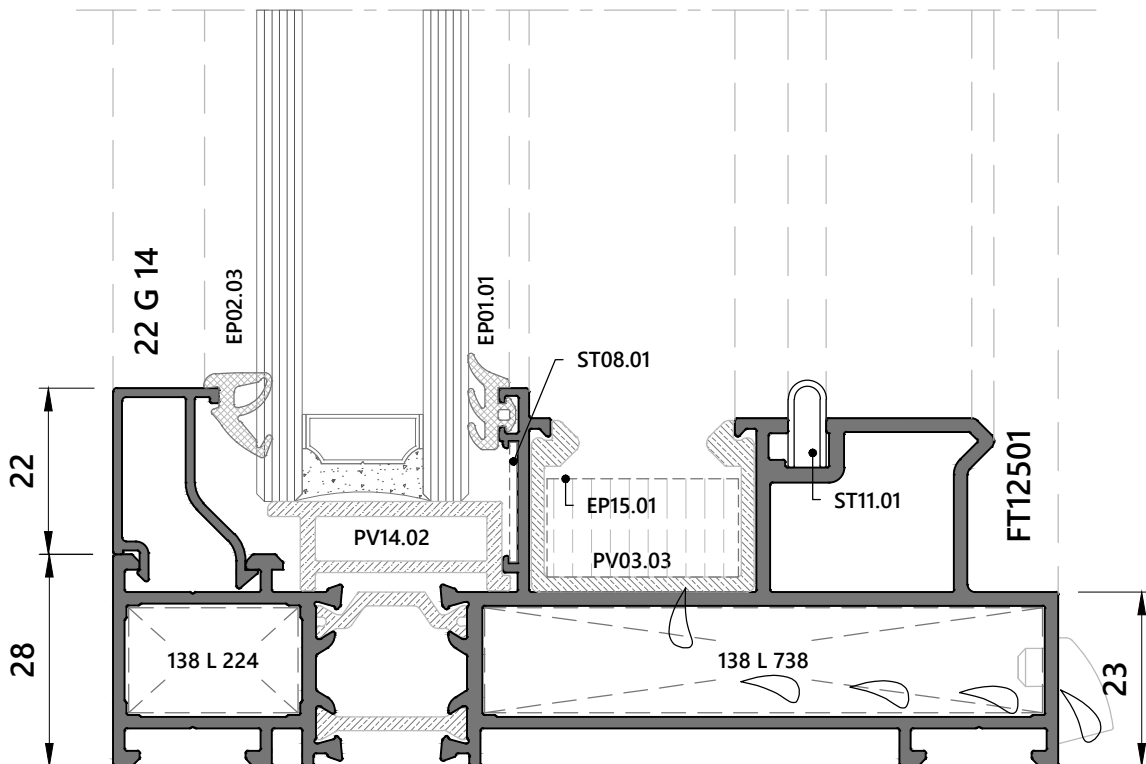
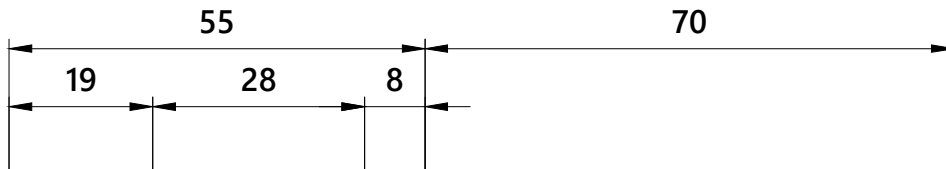

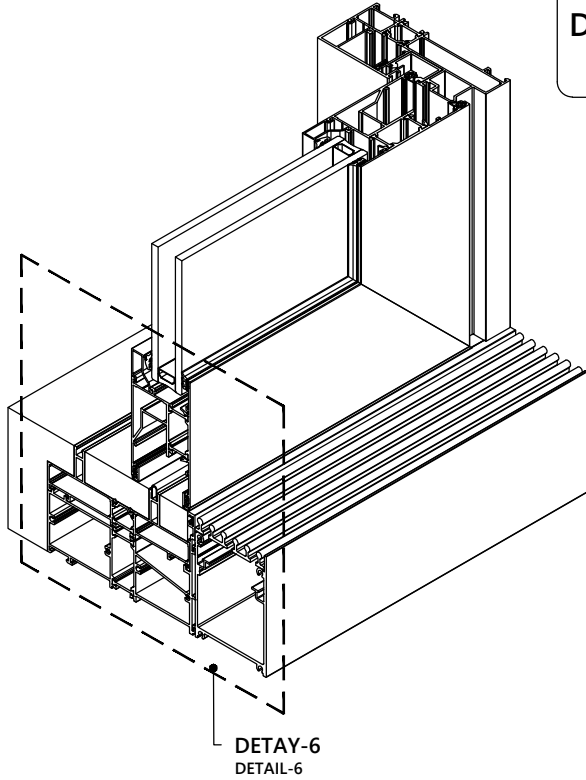

DETAY - 6a
DETAIL - 6a

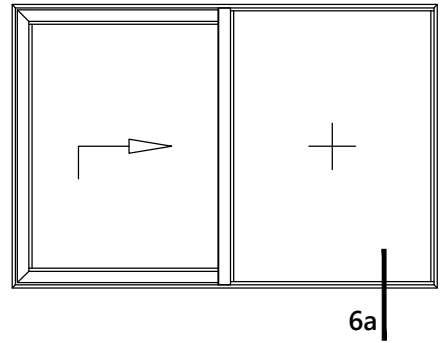

ÖLÇEK : 1/1
Scale : 1/1

DETAY-6
DETAIL-6

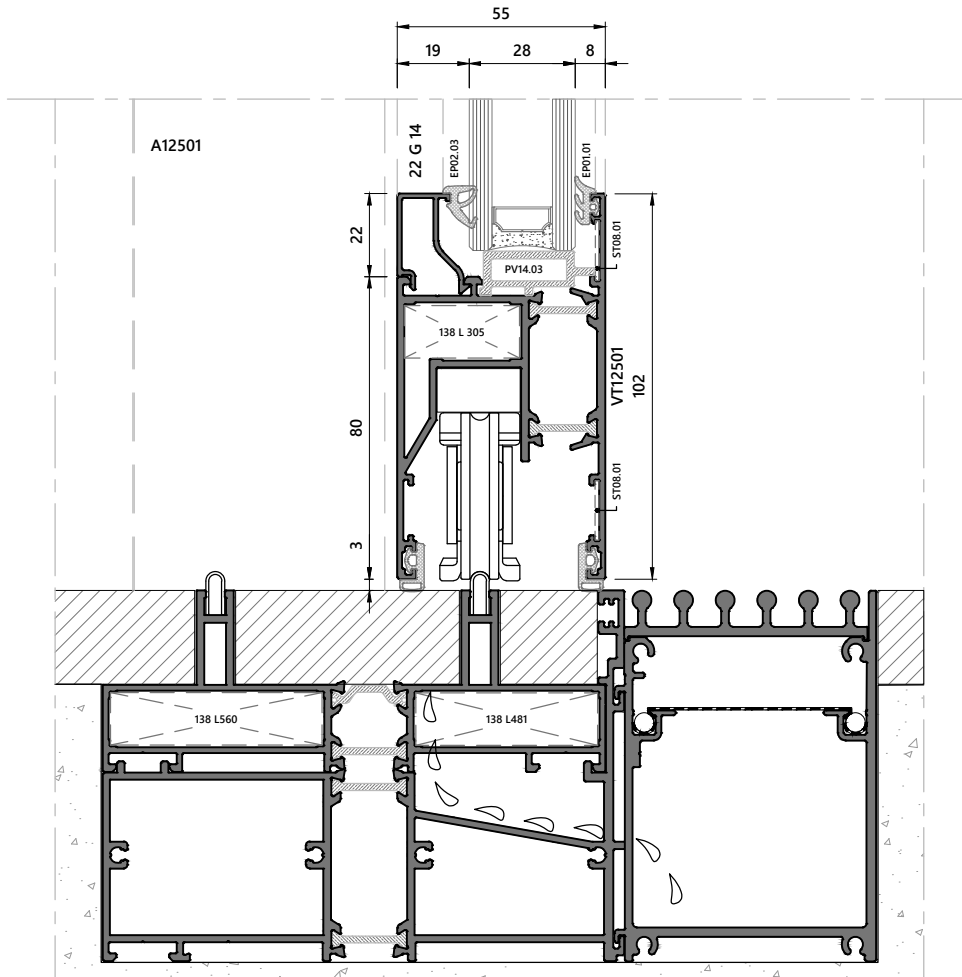

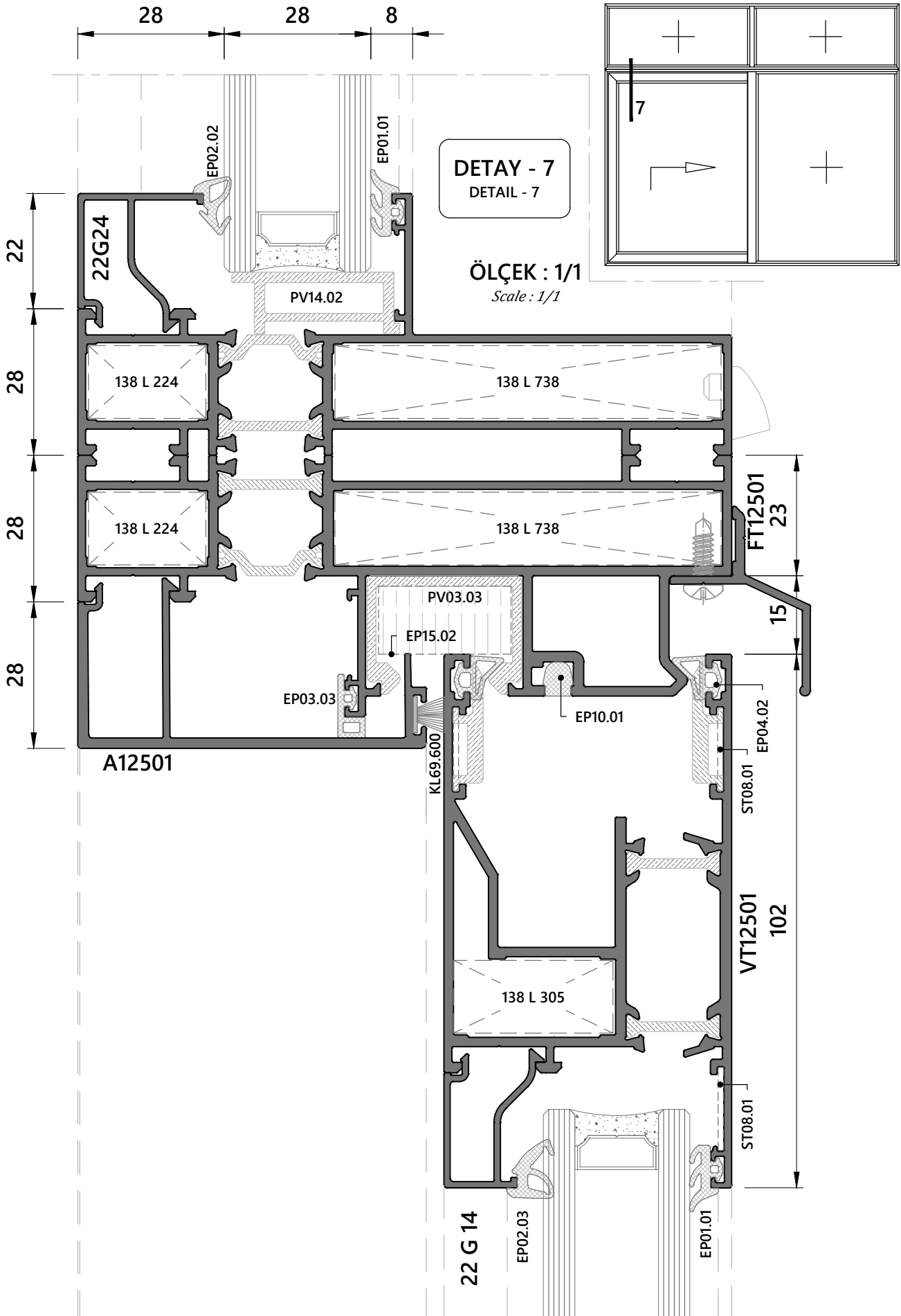

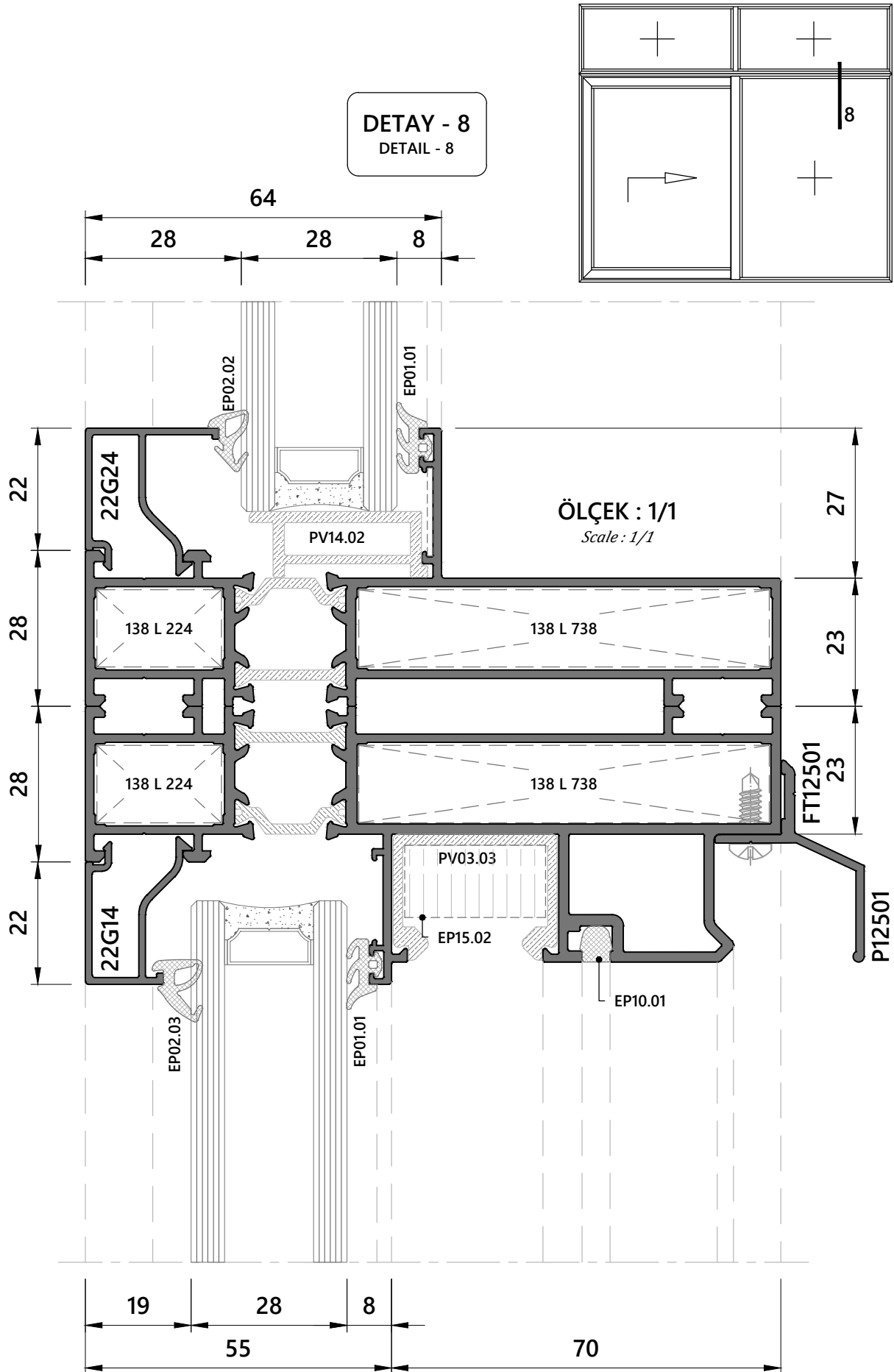

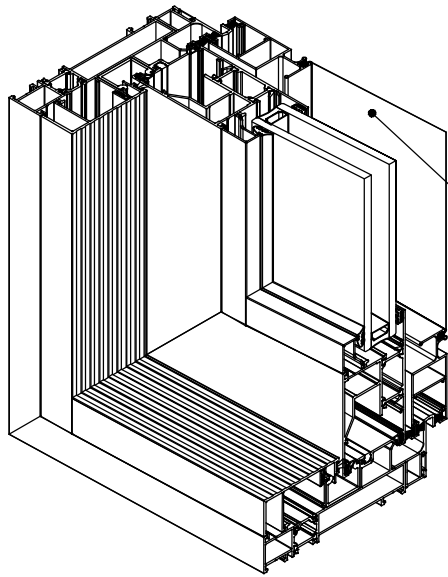

DETAY - 9
DETAIL - 9

DETAY - 9
DETAIL - 9

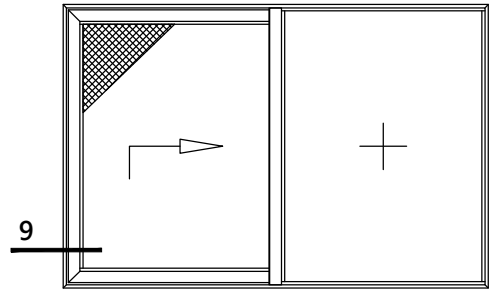

ÖLÇEK : 1/1
Scale : 1/1

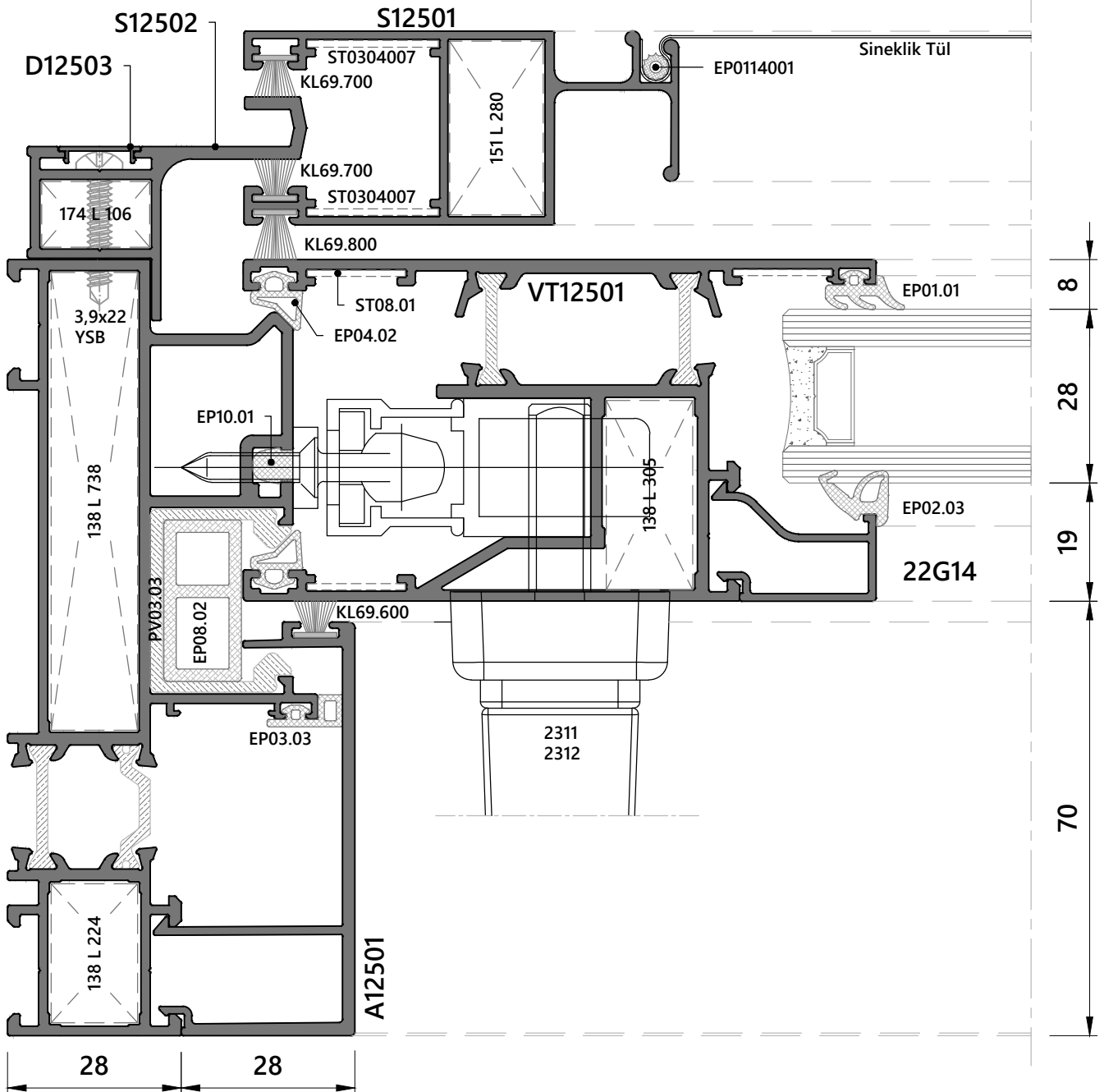

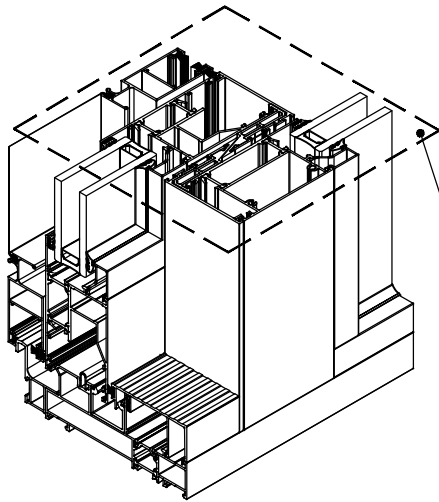

DETAY - 10
DETAIL - 10

DETAY - 10
DETAIL - 10

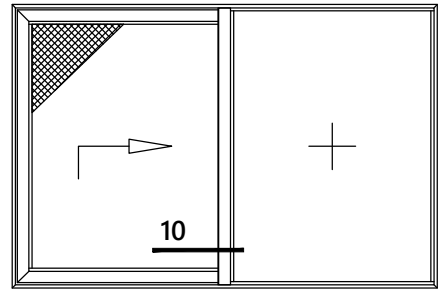

ÖLÇEK : 1/1
Scale : 1/1

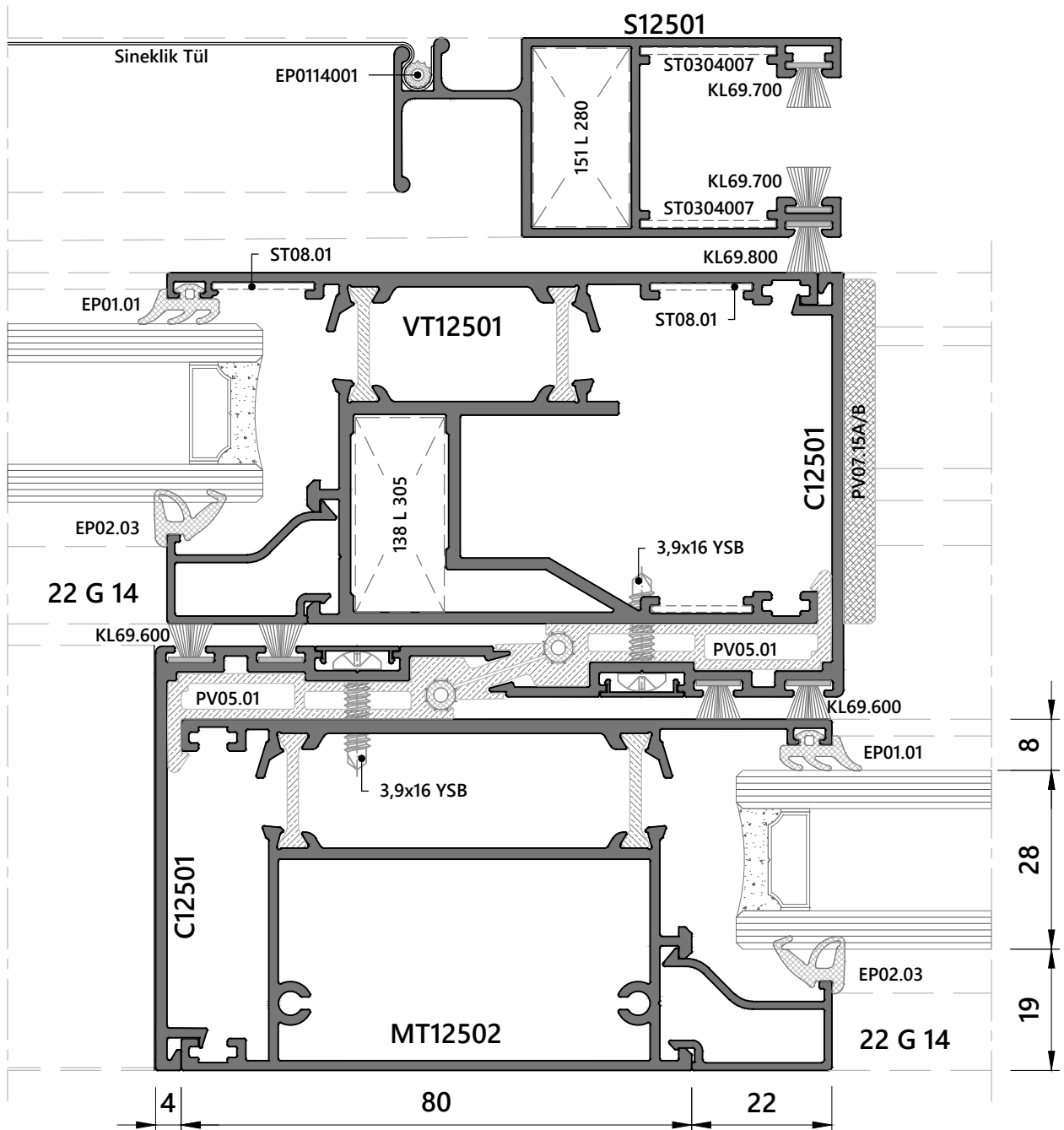

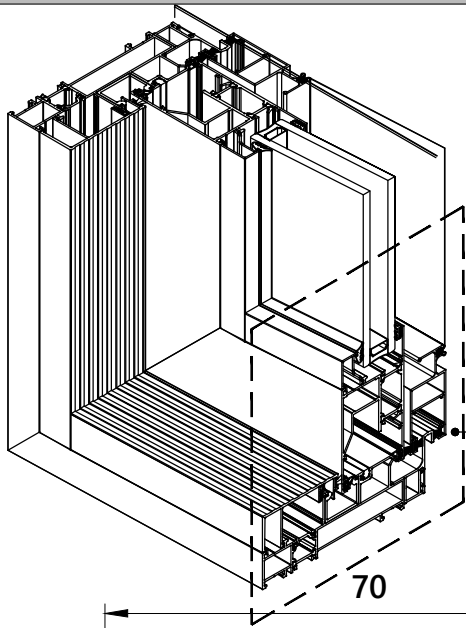

DETAY - 11
DETAIL - 11

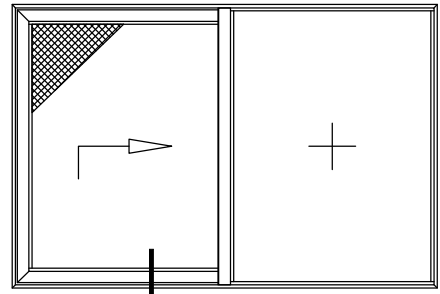

11

ÖLÇEK : 1/1
Scale : 1/1

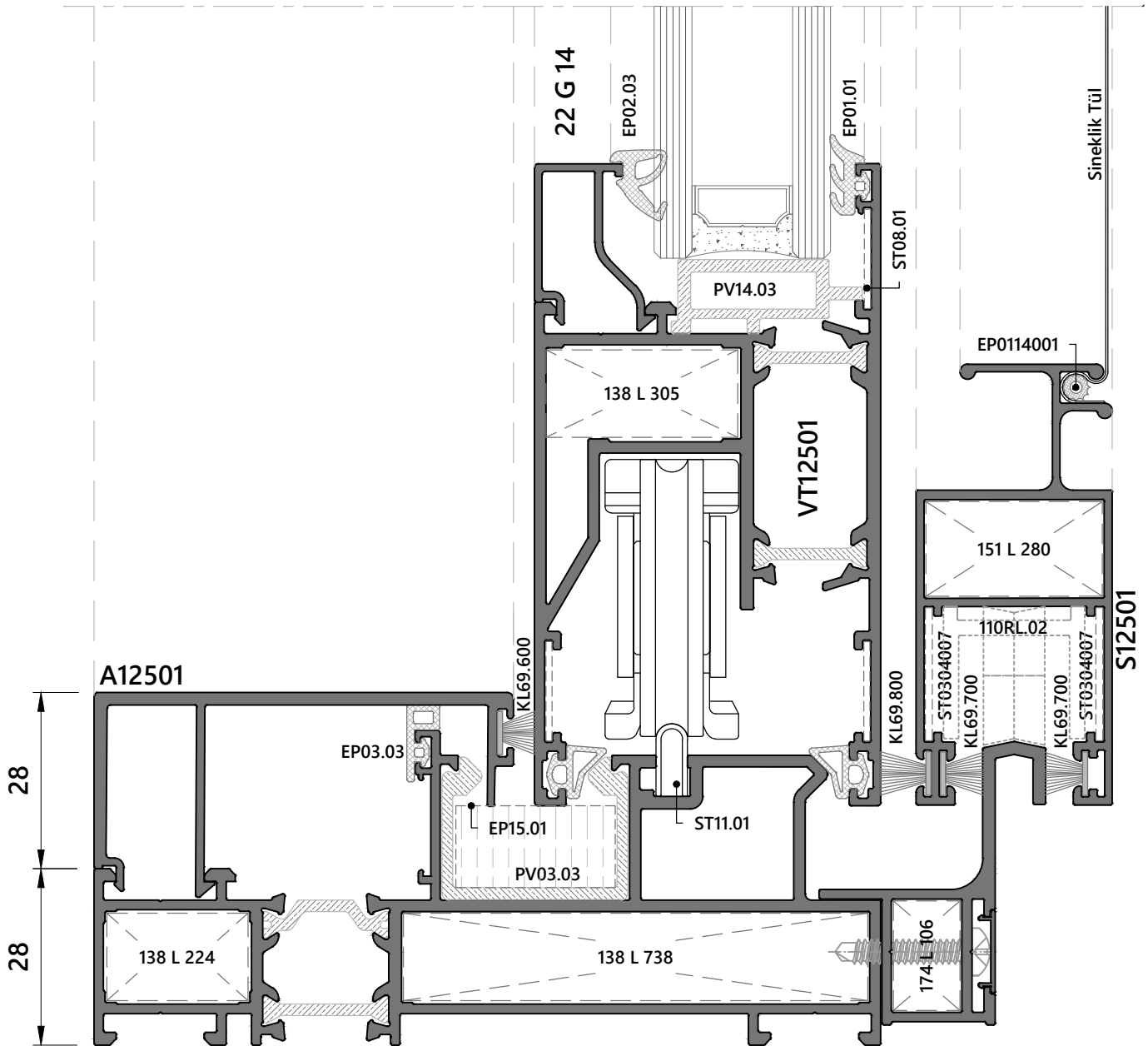
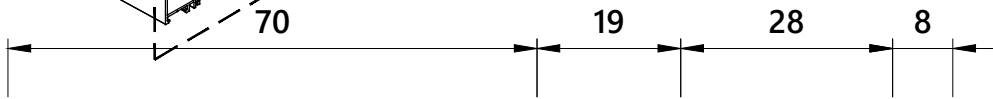

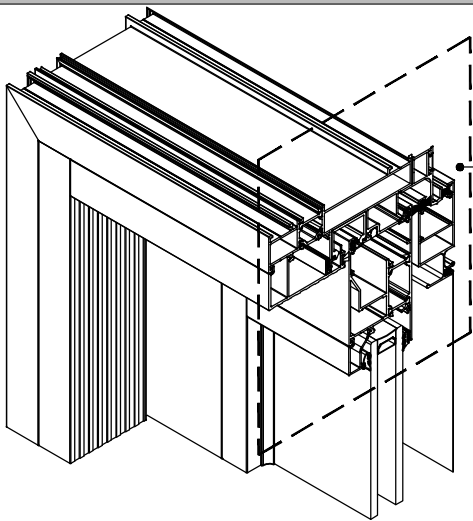

DETAY - 12
DETAIL - 12

DETAY-12
DETAIL-12

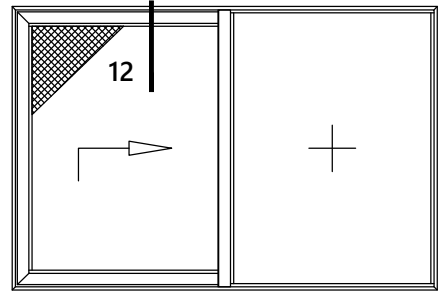

ÖLÇEK : 1/1
Scale : 1/1

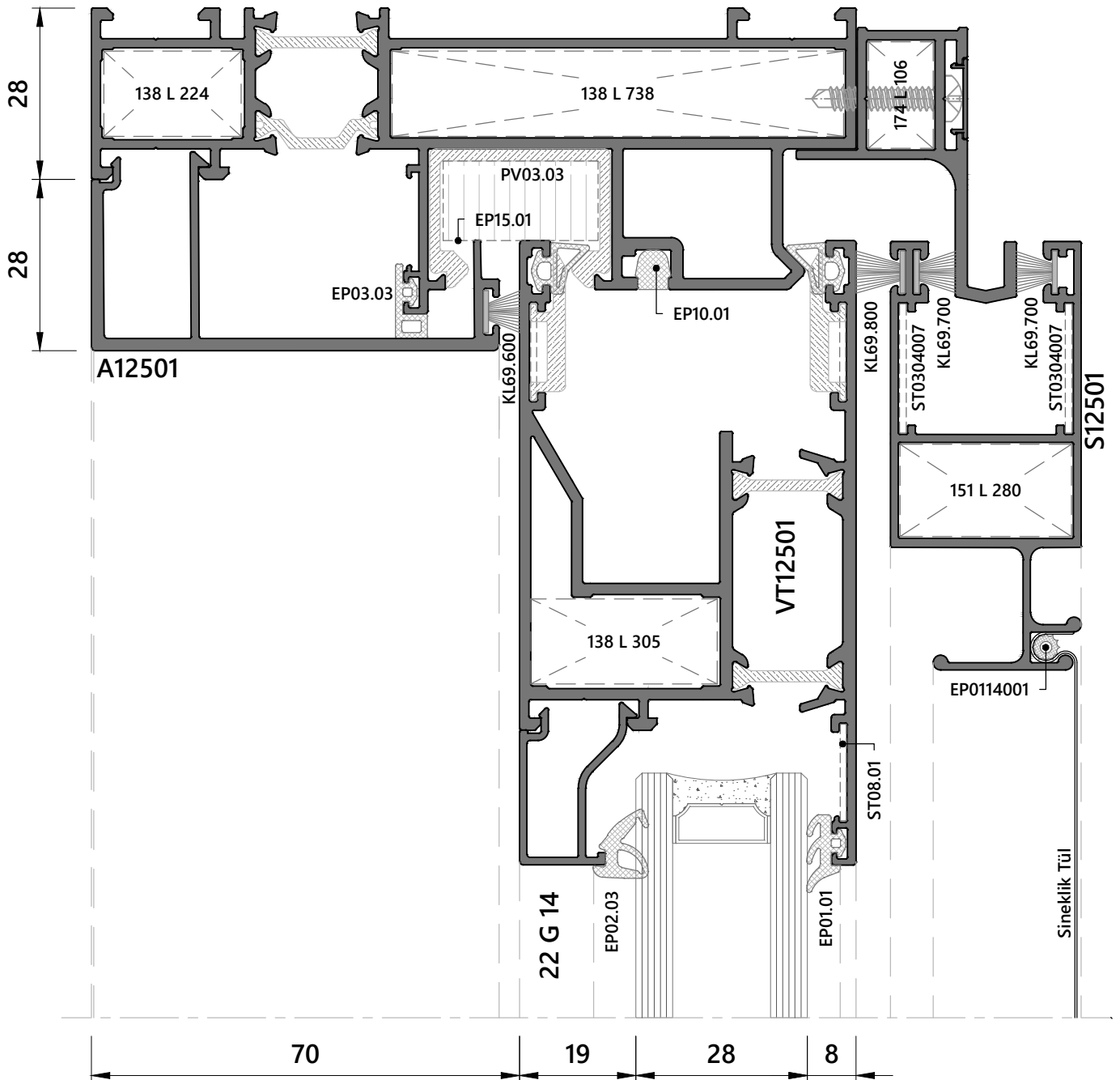

KLASİK SÜRME AÇILIM TİPLERİ

SLIDING TYPES OF OPENING

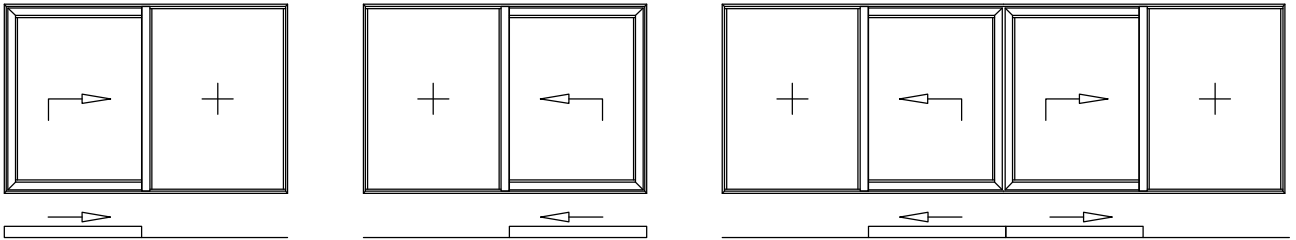

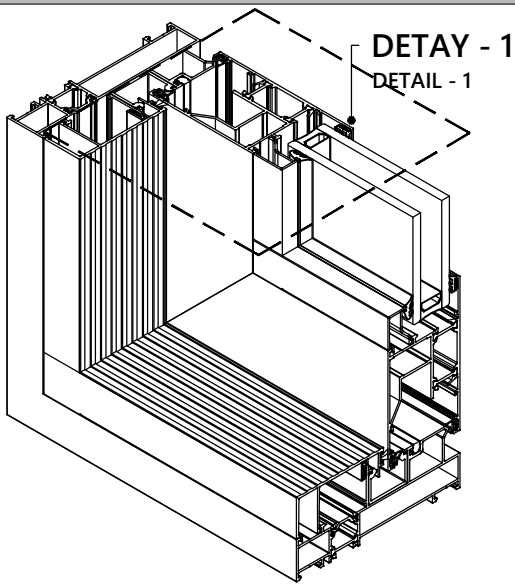

DETAY - 1
DETAIL - 1

DETAY - 1
DETAIL - 1

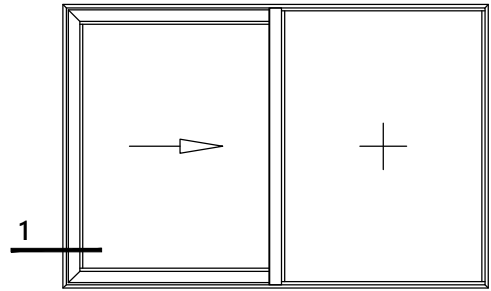

ÖLÇEK : 1/1
Scale : 1/1

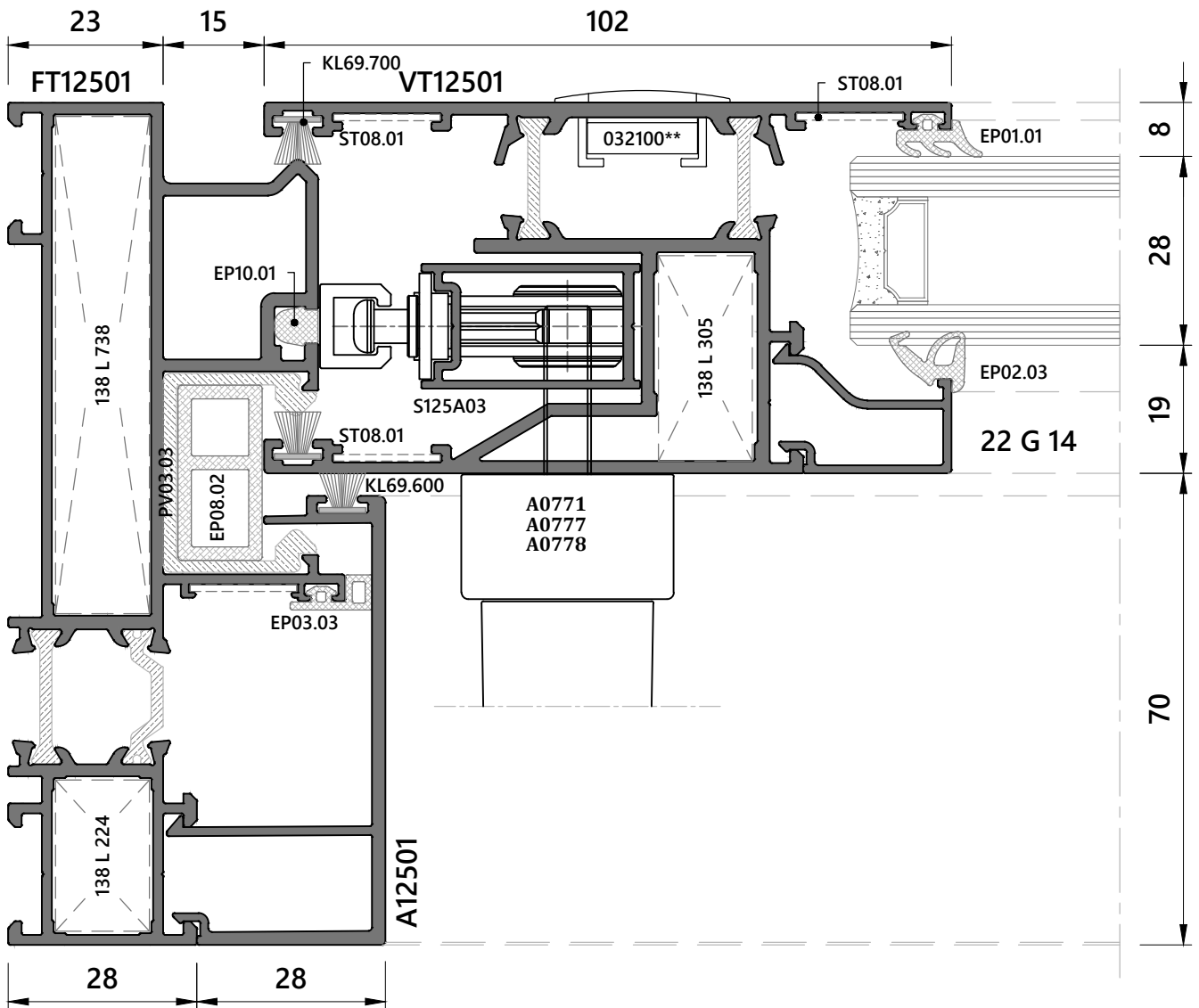

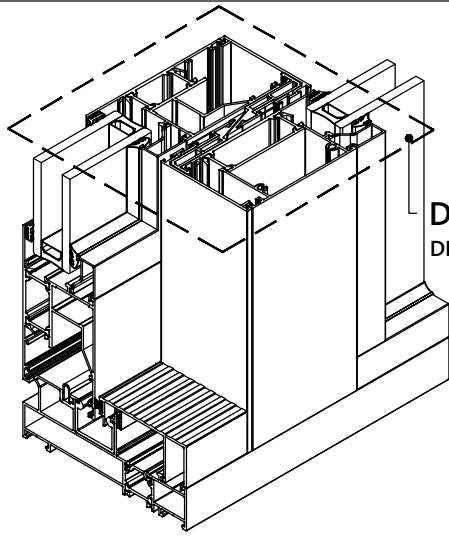

DETAY - 2
DETAIL - 2

DETAY - 2
DETAIL - 2

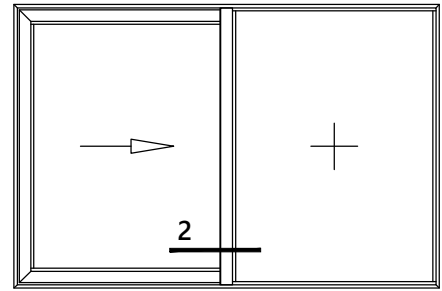

ÖLÇEK : 1/1
Scale : 1/1

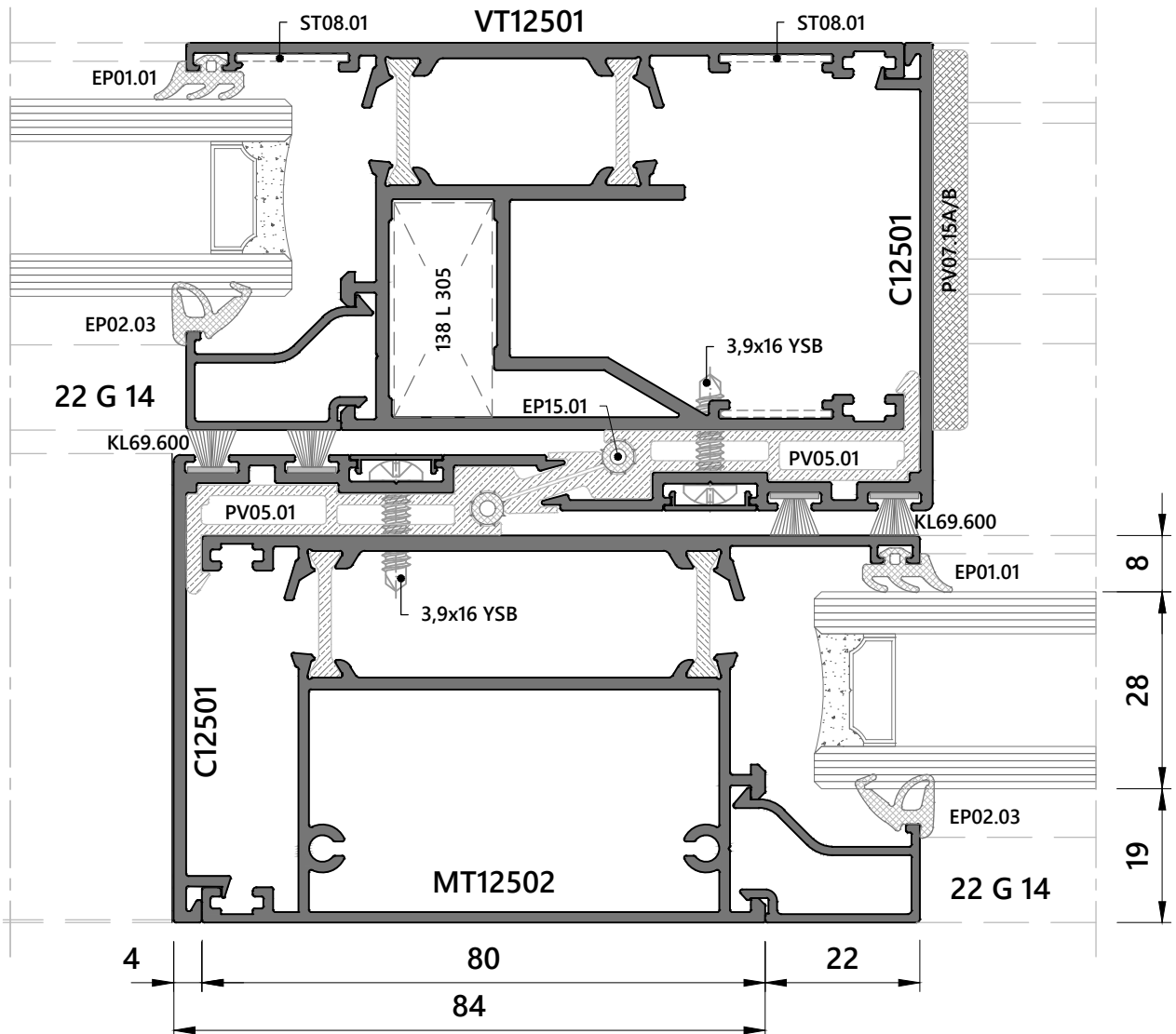

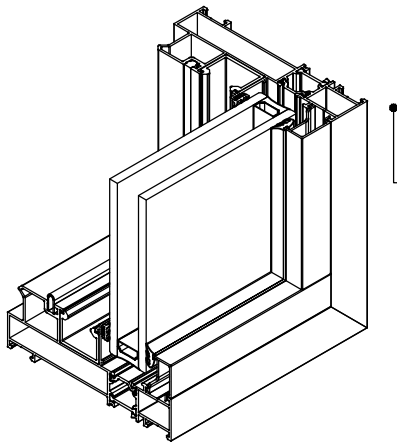

DETAY - 3
DETAIL - 3

DETAY - 3
DETAIL - 3

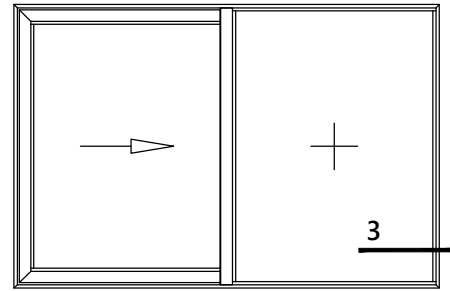

ÖLÇEK : 1/1
Scale : 1/1

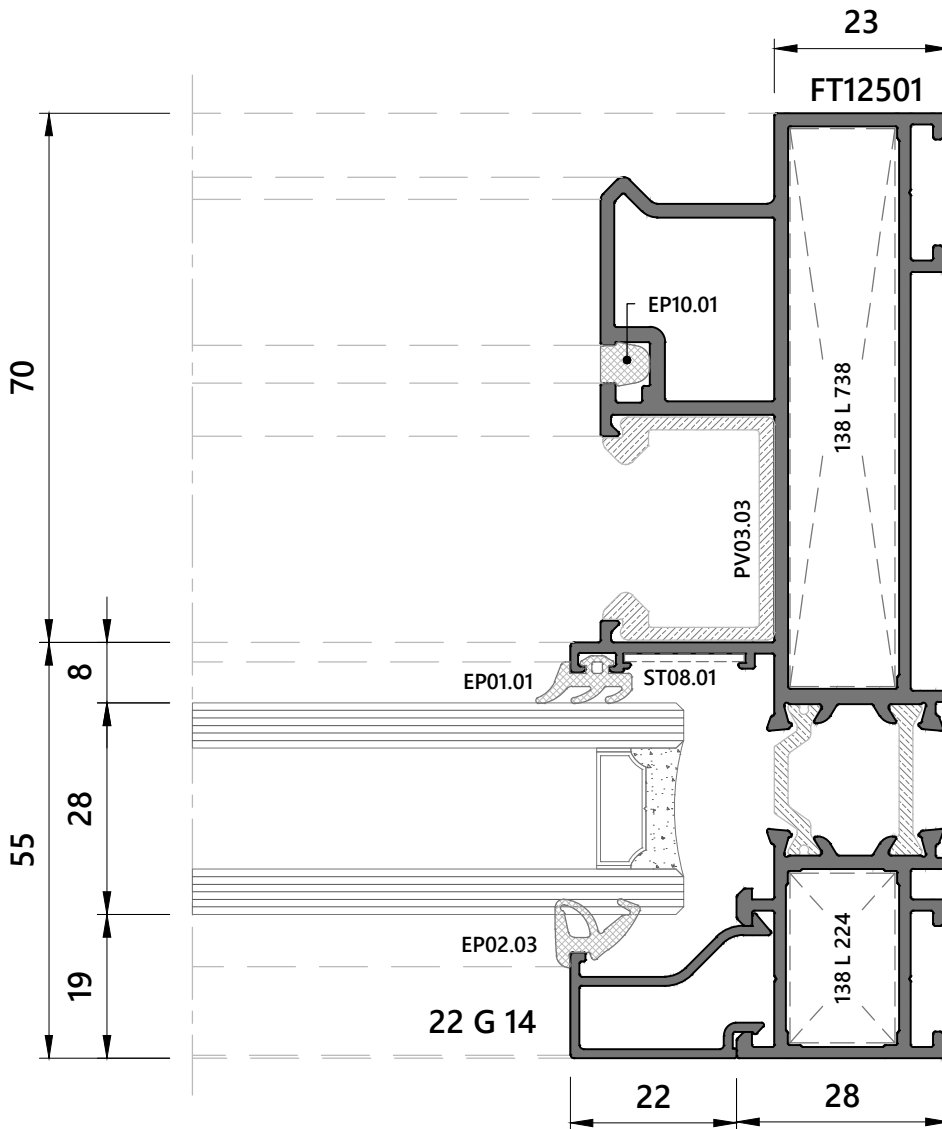

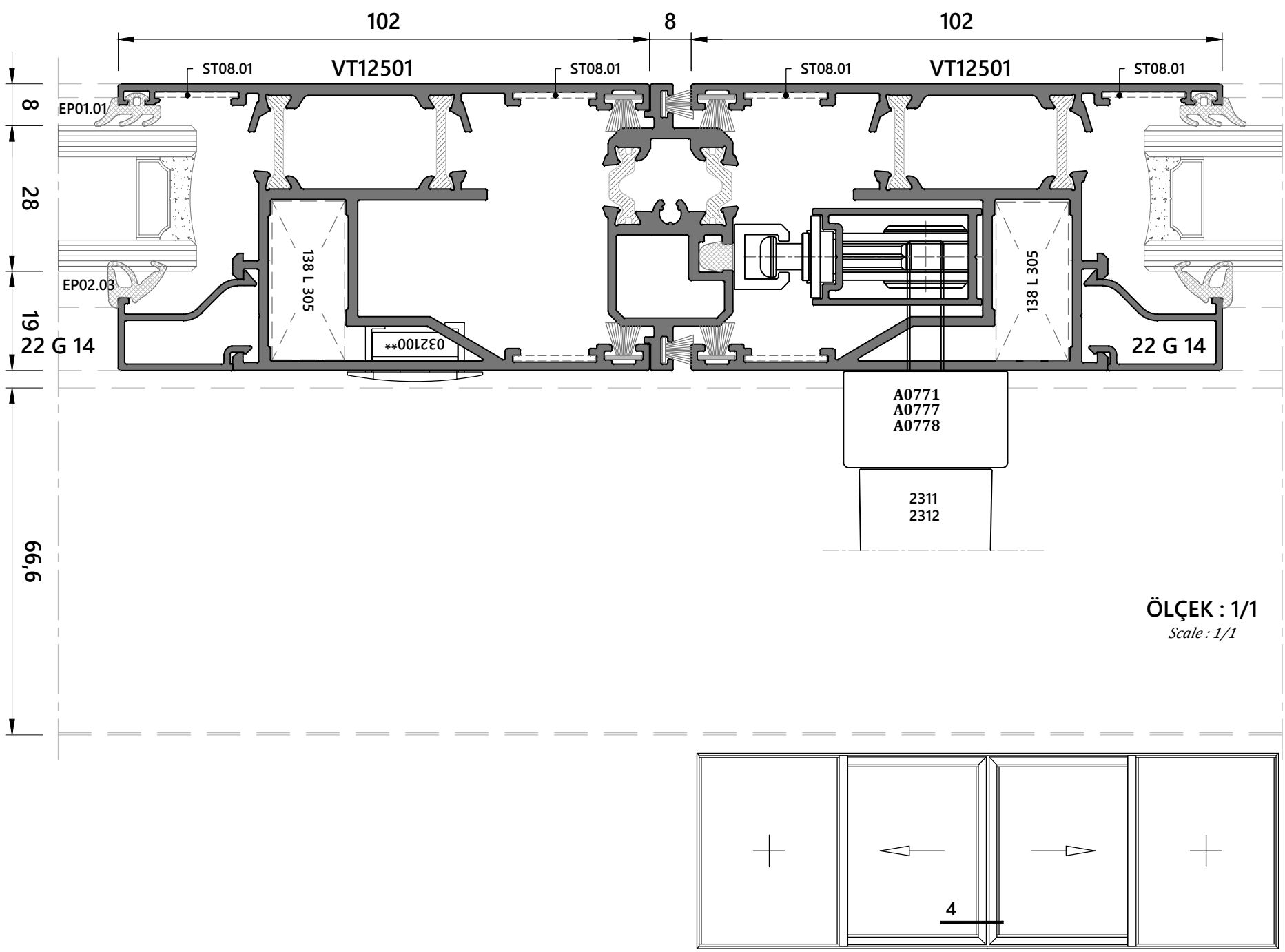

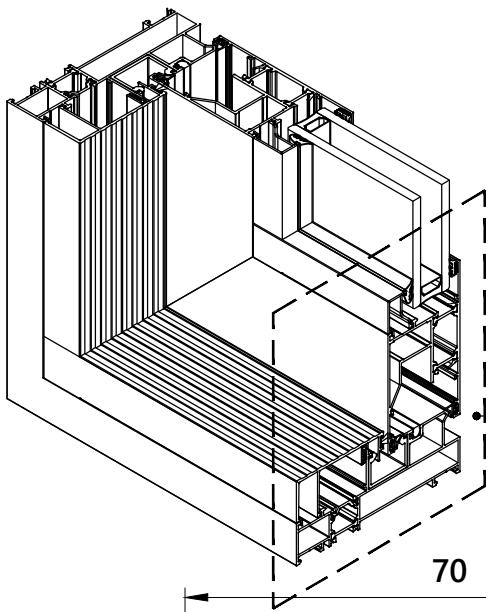

DETAIL - 5
DETAIL - 5

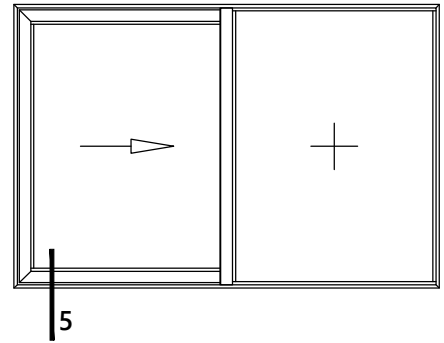

ÖLÇEK : 1/1
Scale : 1/1

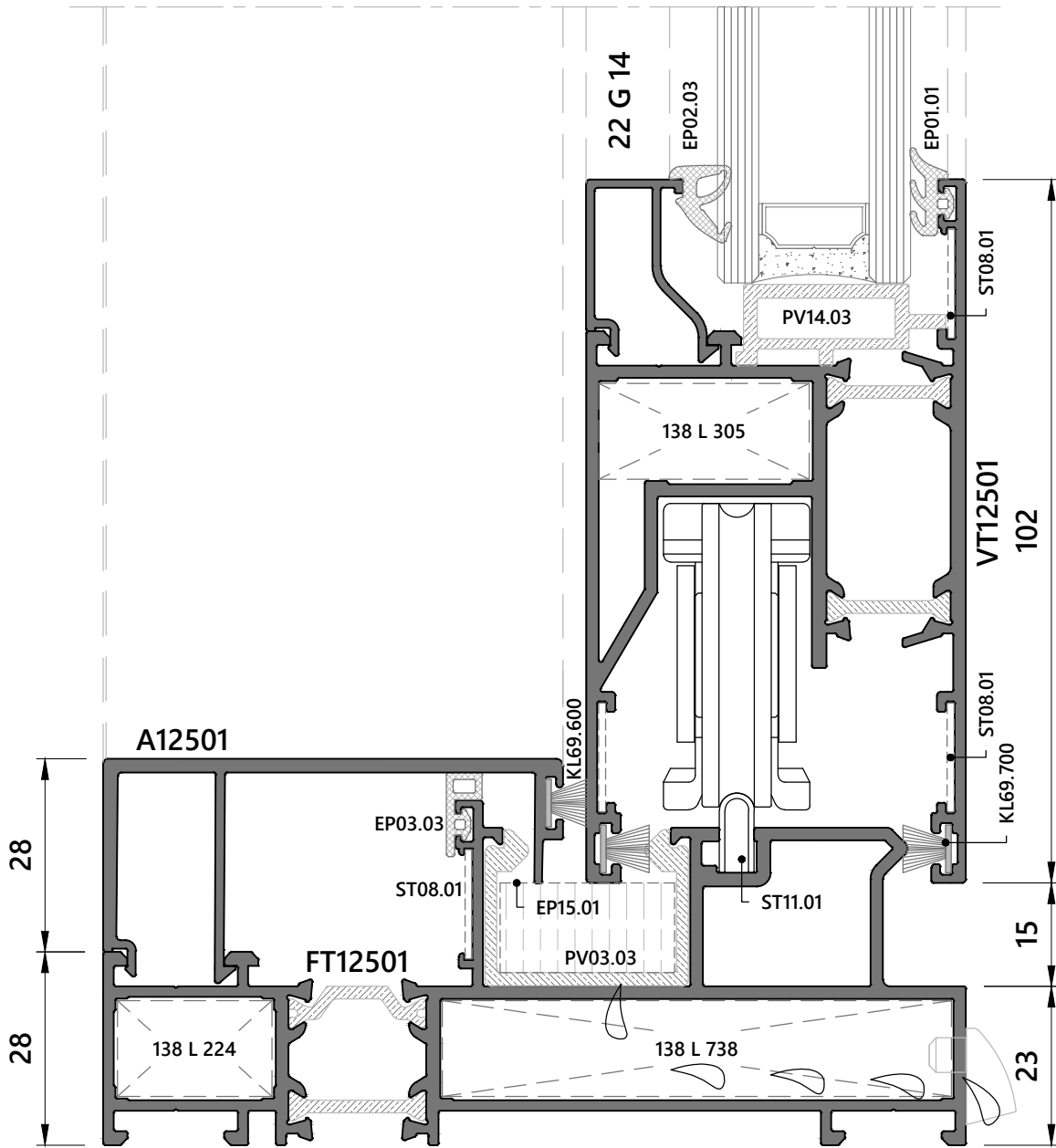

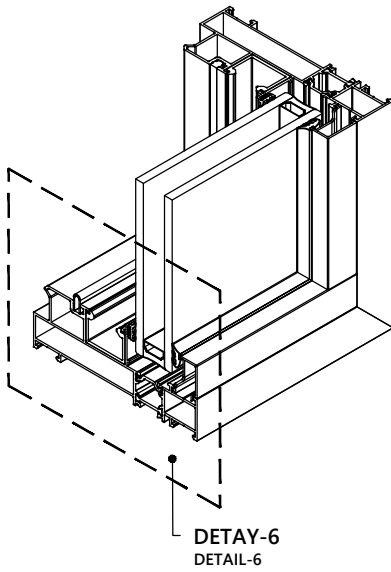

DETAY - 6
DETAIL - 6

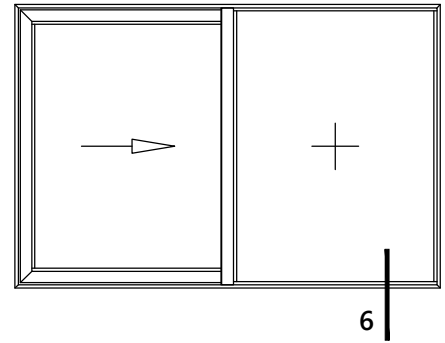

ÖLÇEK : 1/1
Scale : 1/1

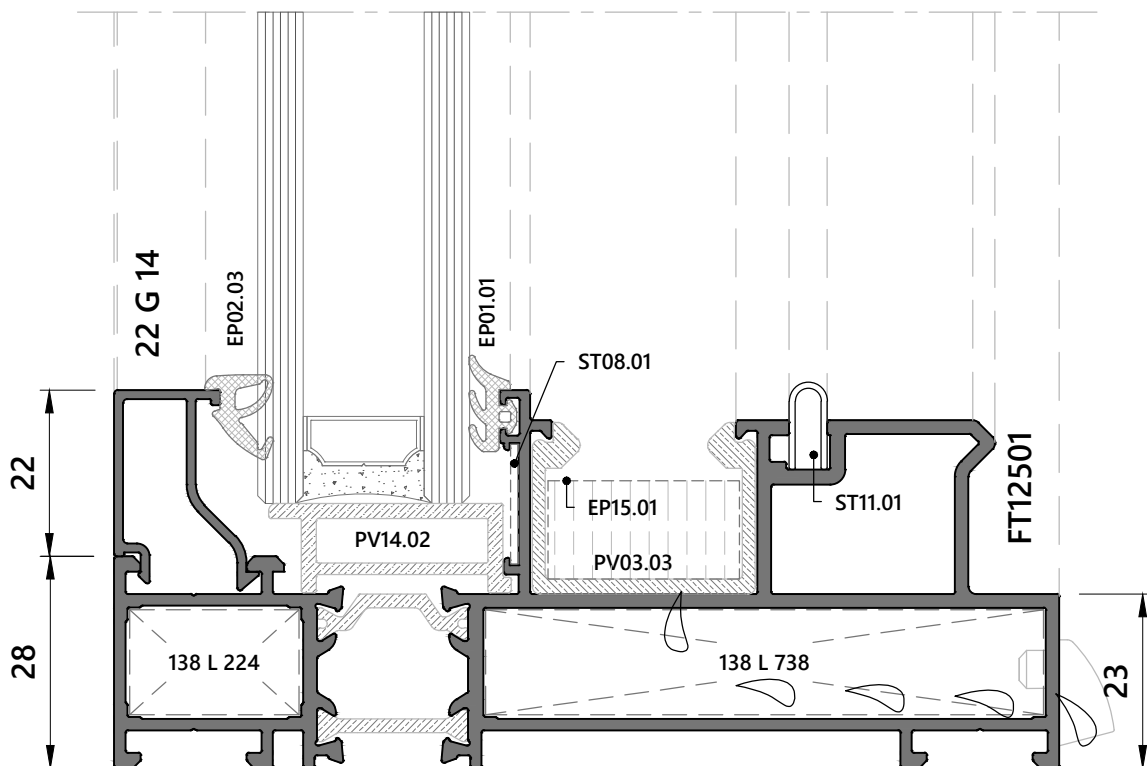
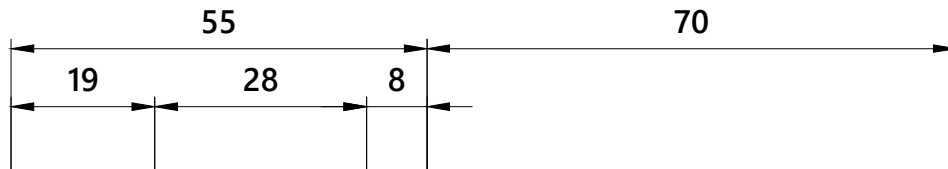

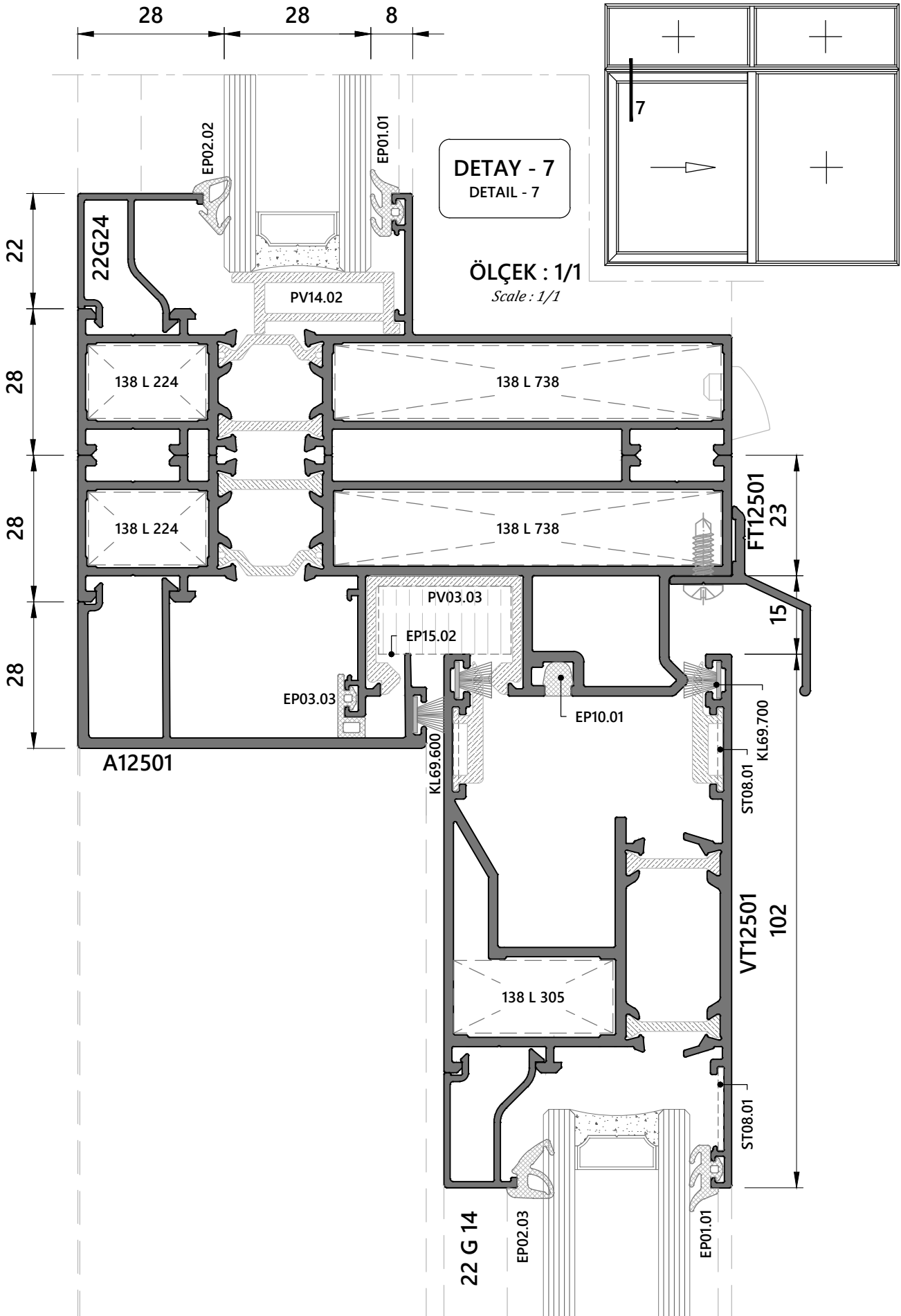

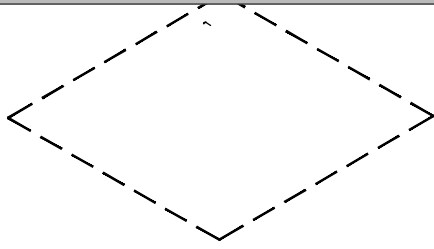

DETAJ - 8
DETAIL - 8

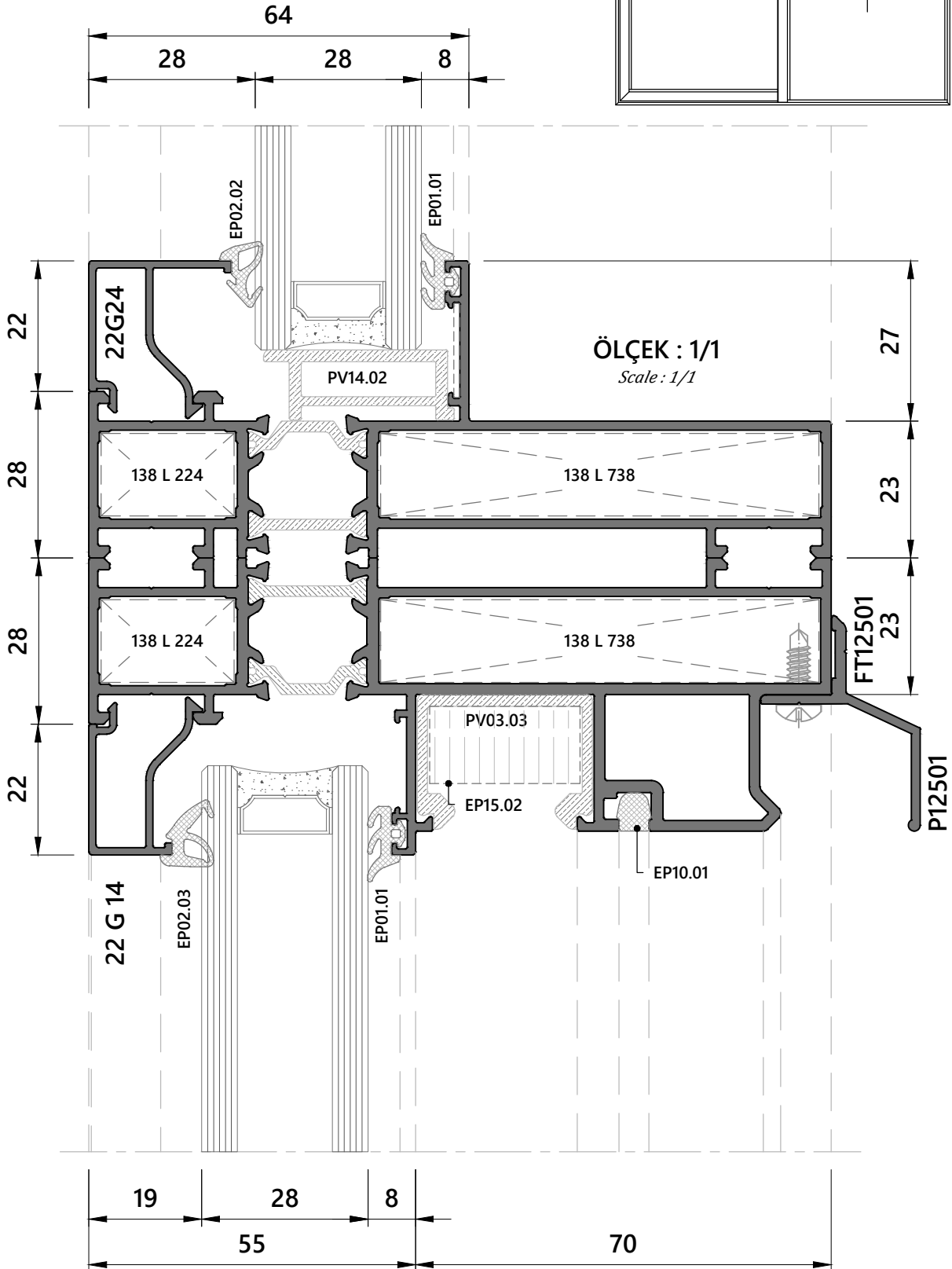
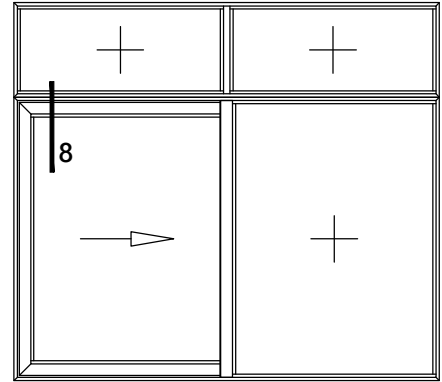

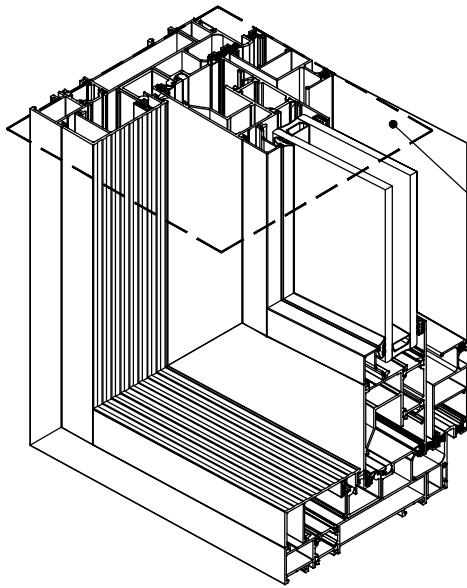

DETAY - 9
DETAIL - 9

DETAY - 9
DETAIL - 9

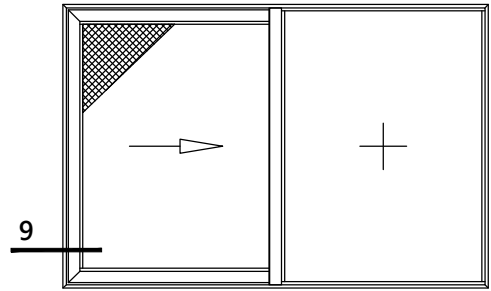

ÖLÇEK : 1/1
Scale : 1/1

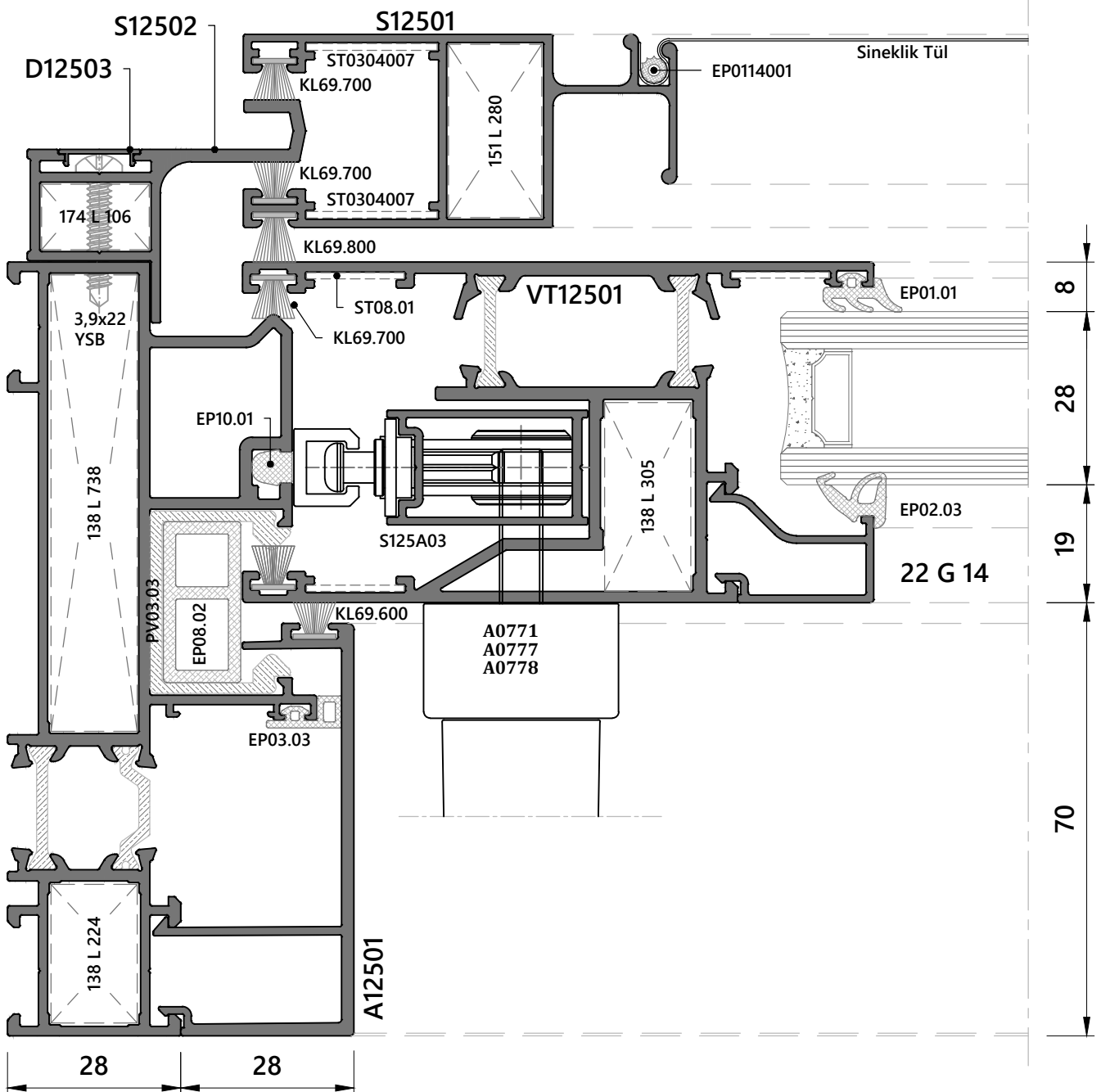

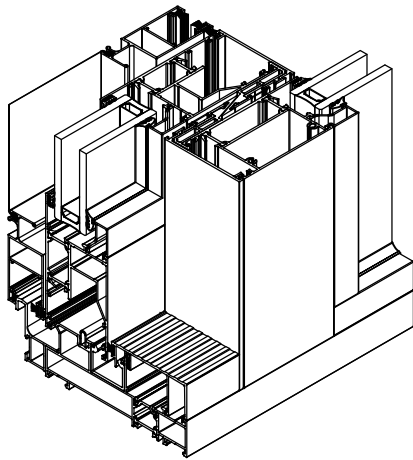

DETAY - 10
DETAIL - 10

DETAY - 10
DETAIL - 10

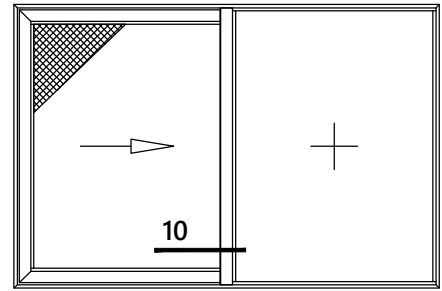

ÖLÇEK : 1/1
Scale : 1/1

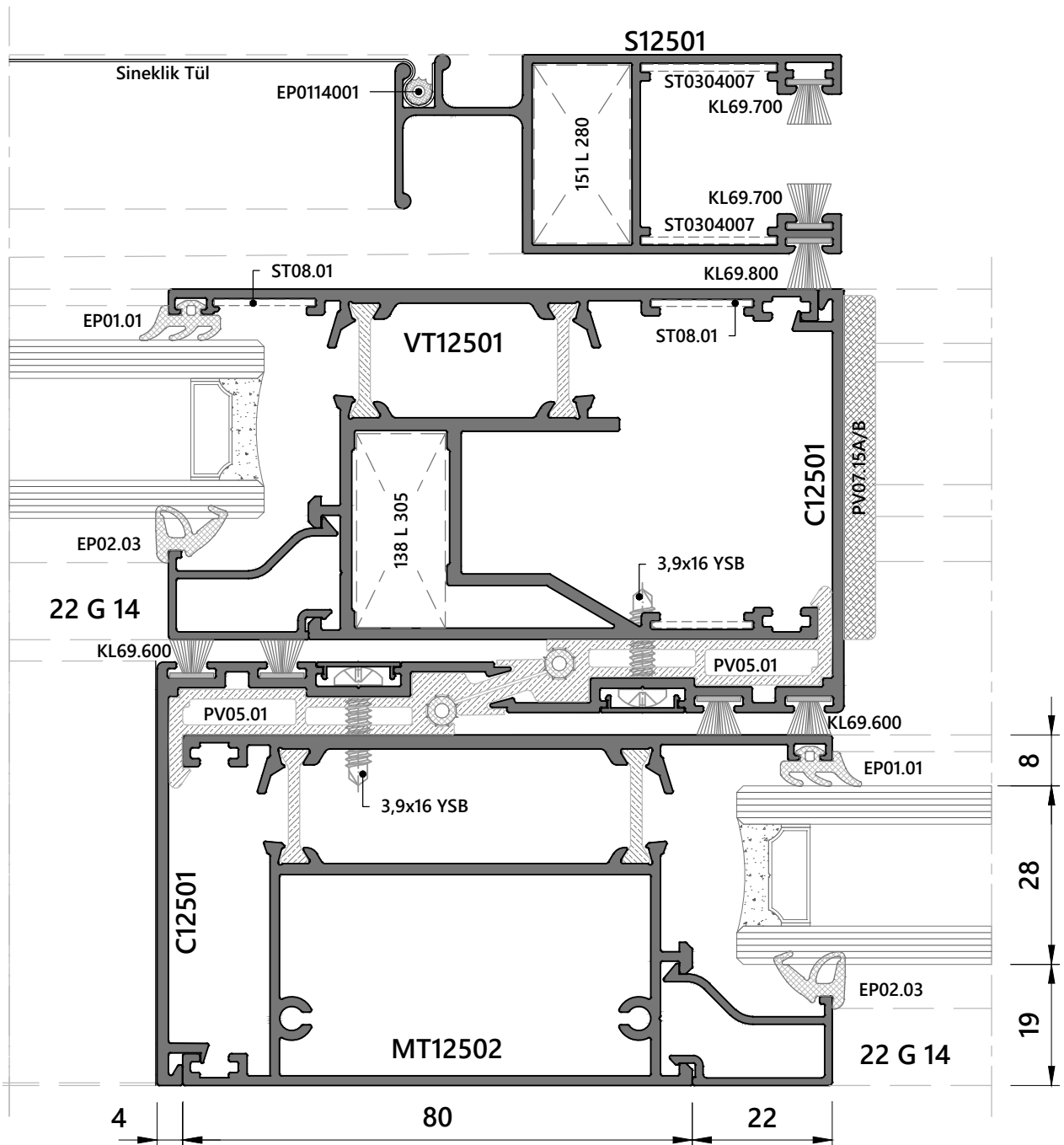

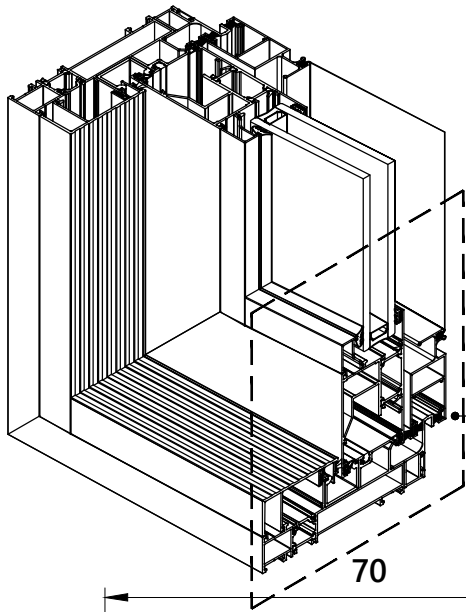

DETAY - 11
DETAIL - 11

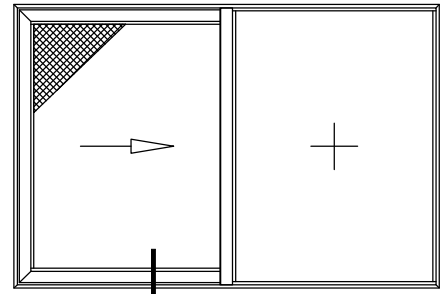

11

ÖLÇEK : 1/1
Scale : 1/1

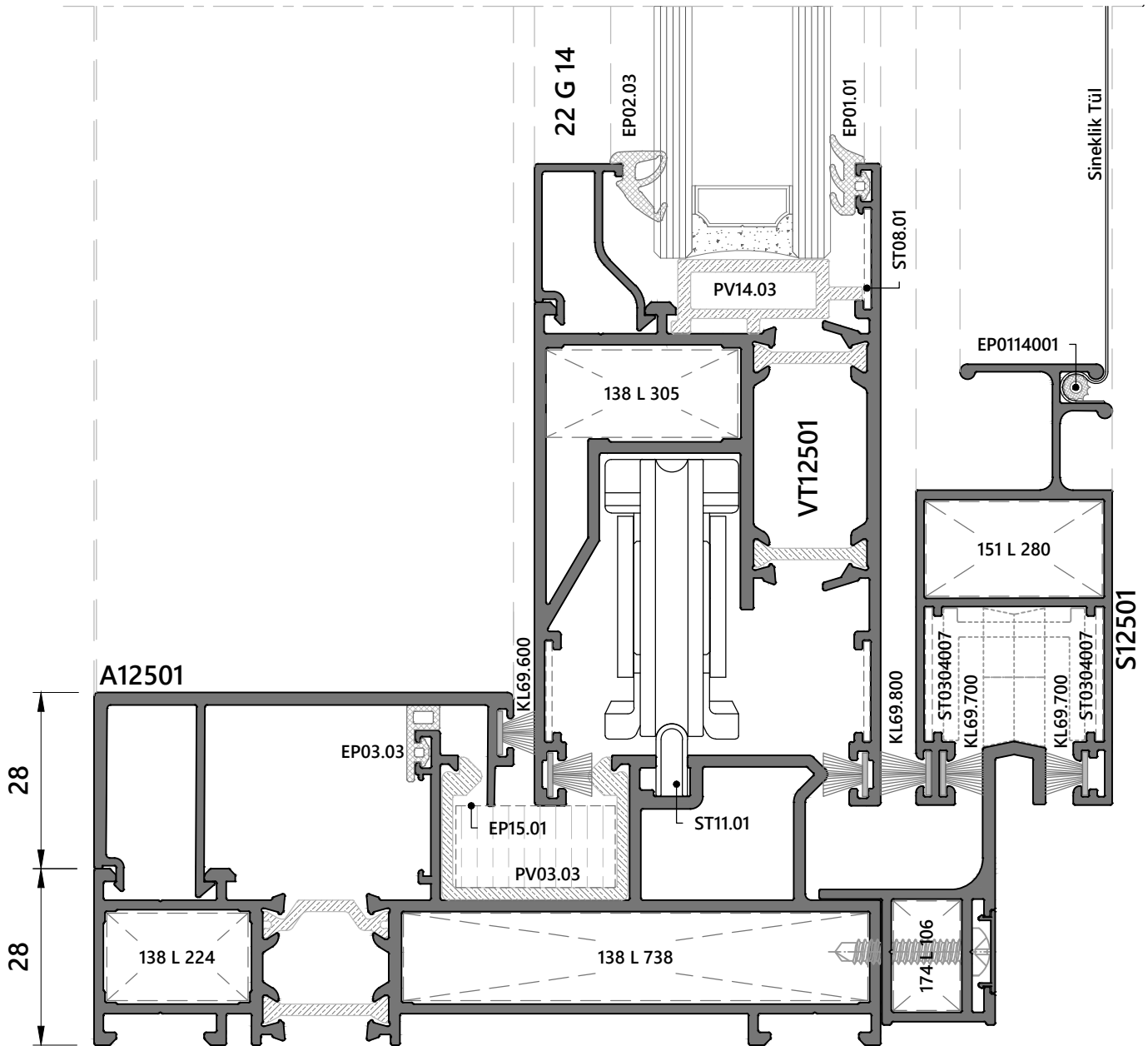
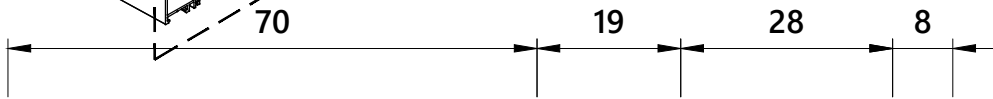

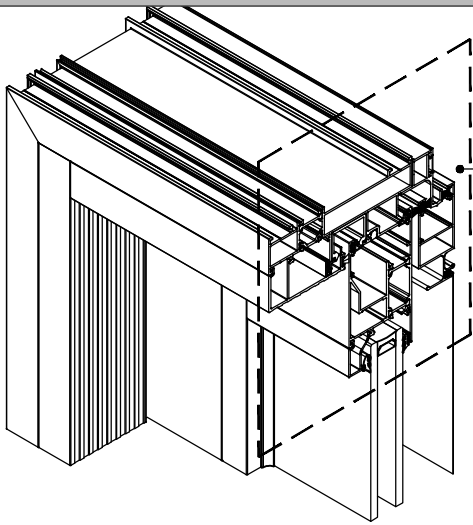

DETAY - 12
DETAIL - 12

DETAY-12
DETAIL-12

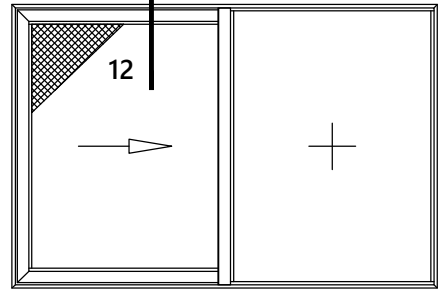

ÖLÇEK : 1/1
Scale : 1/1

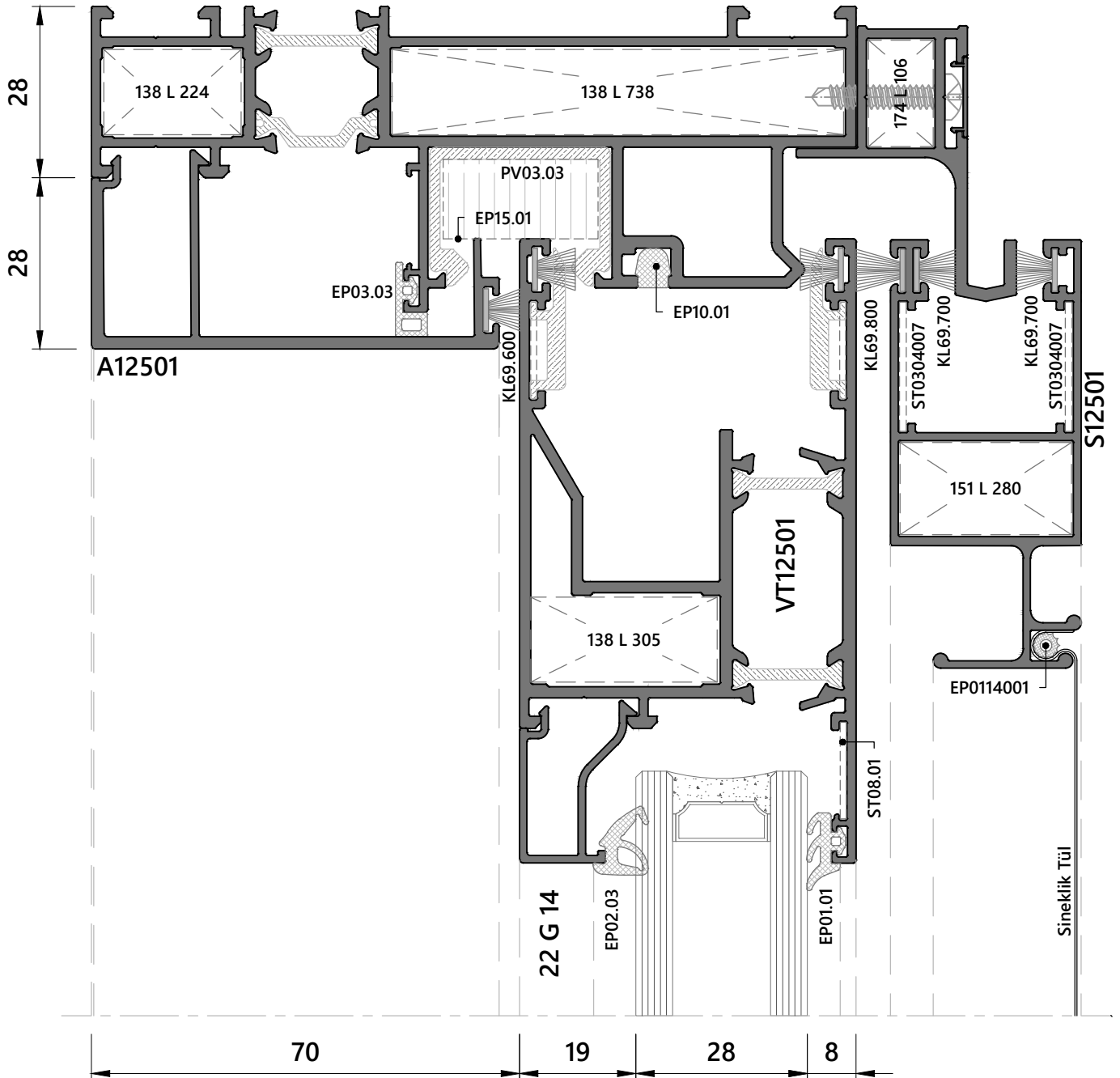

KANAT İÇTE ÇALIŞIR
TEK RAYLI KASA UYGULAMA DETAYLARI
MONORAIL FRAME APPLICATION DETAILS

KALDIRSÜR AÇILIM TİPLERİ

LIFT&SLIDE TYPES OF OPENING

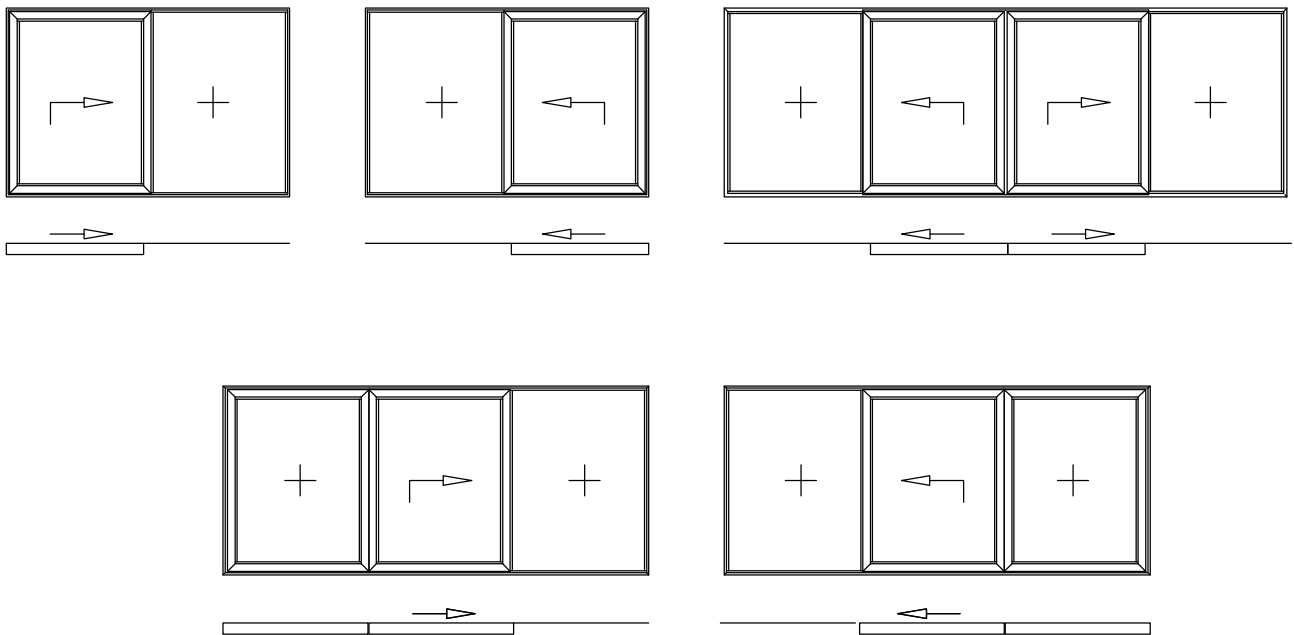

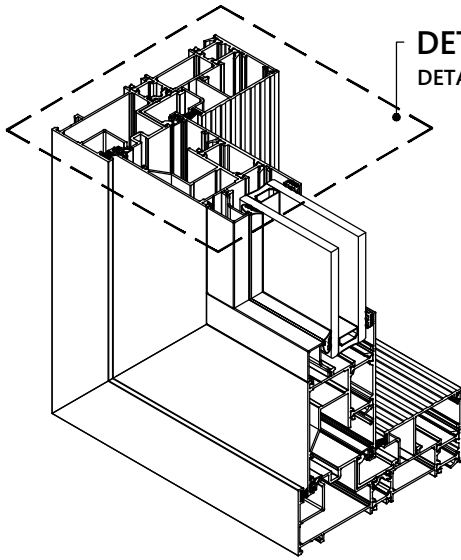

DETAY - 1
DETAIL - 1

DETAY - 1
DETAIL - 1

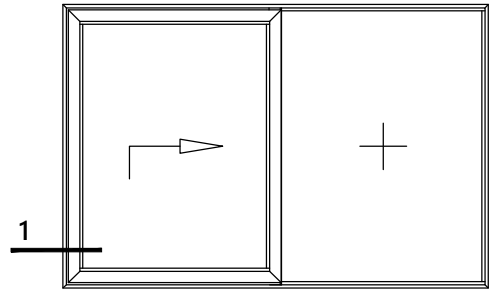

ÖLÇEK : 1/1
Scale : 1/1

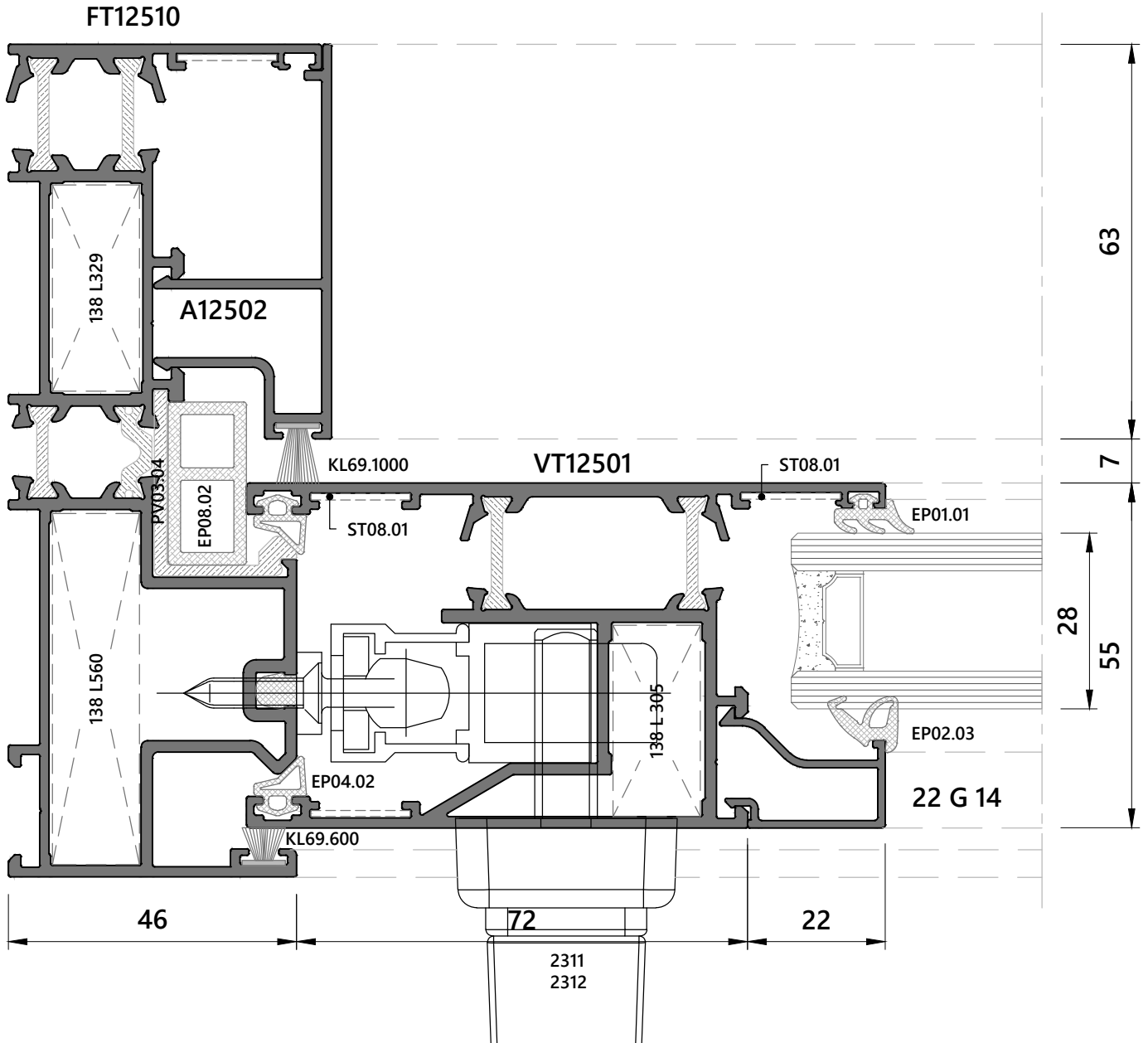

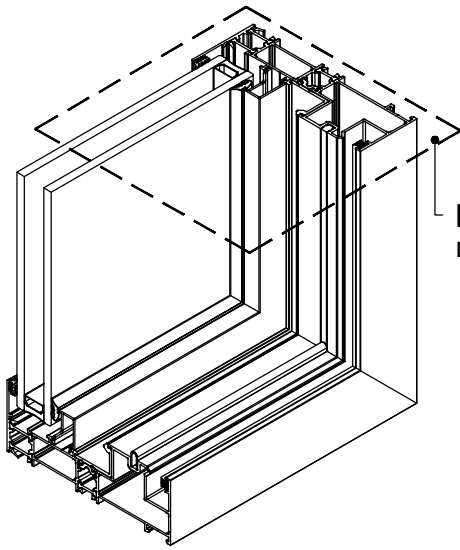

DETAY - 3
DETAIL - 3

DETAY - 3
DETAIL - 3

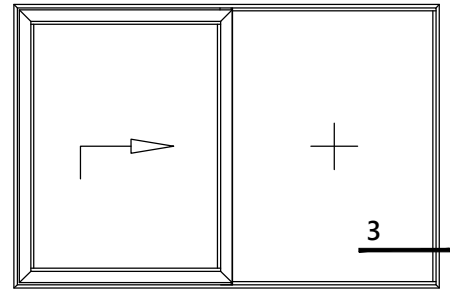

ÖLÇEK : 1/1
Scale : 1/1

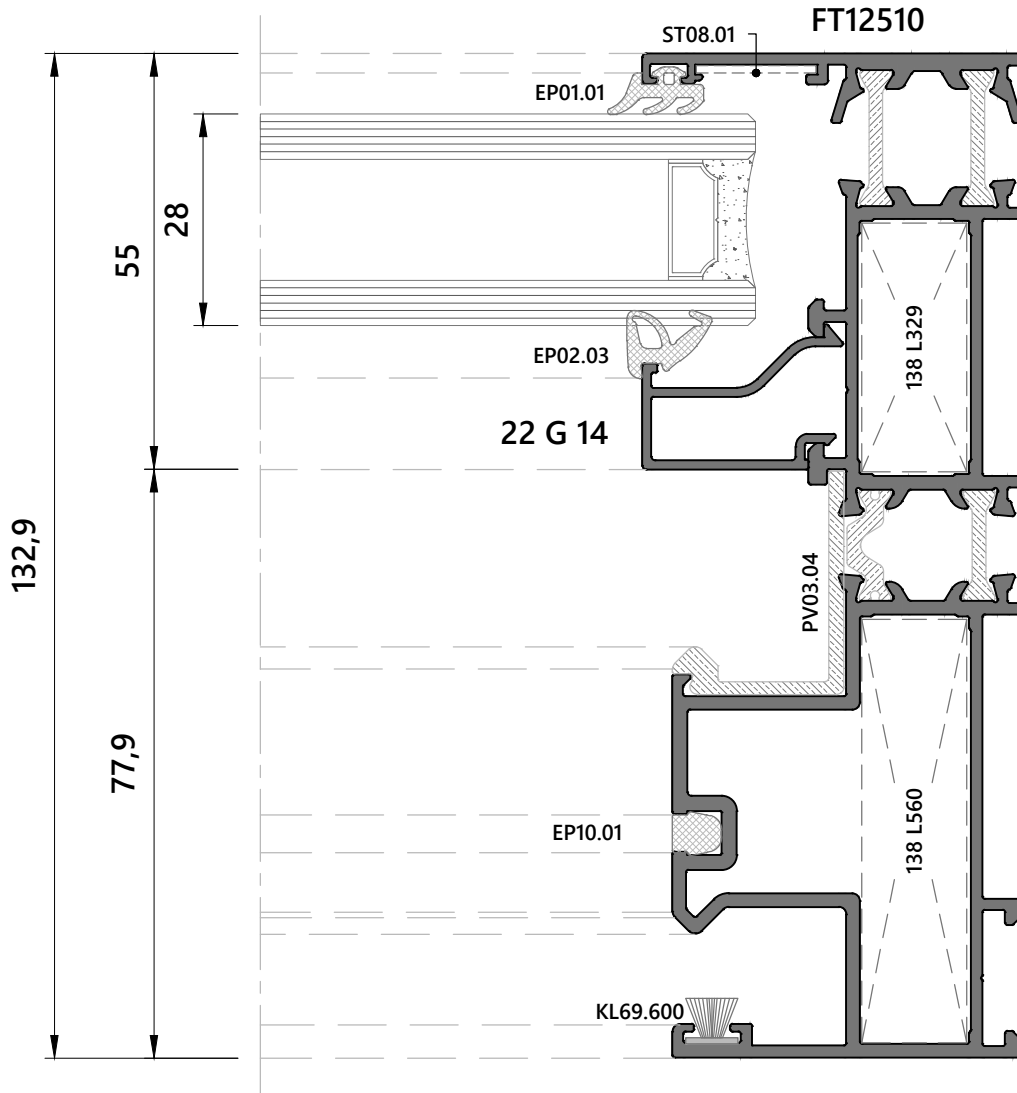

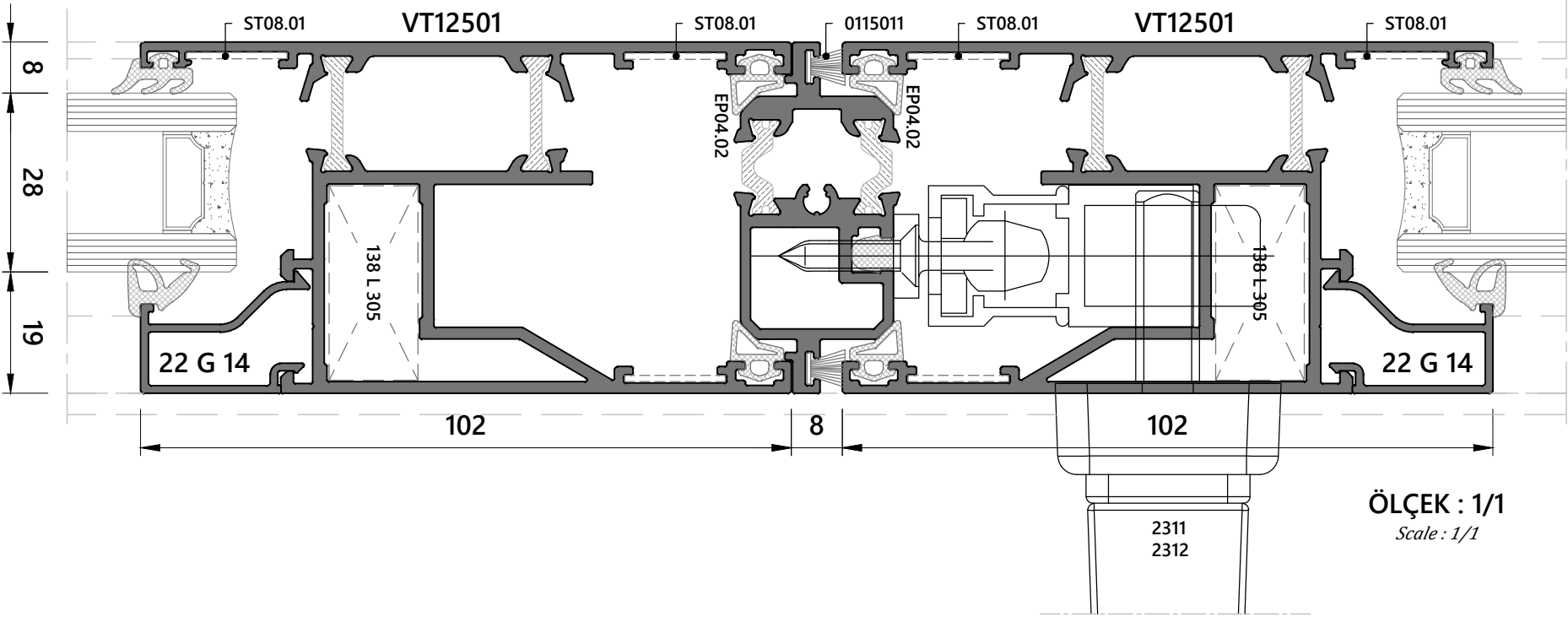
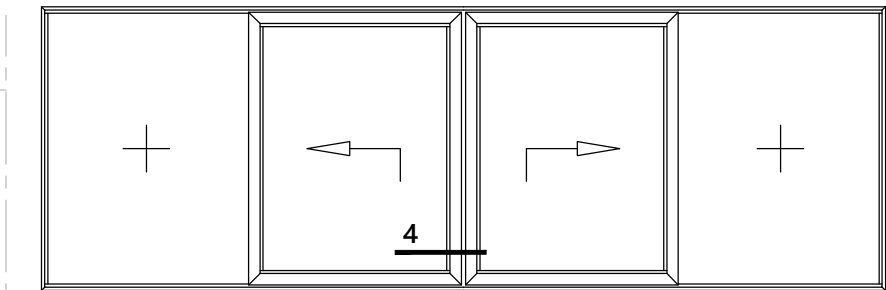

DETAY - 5
DETAIL - 5

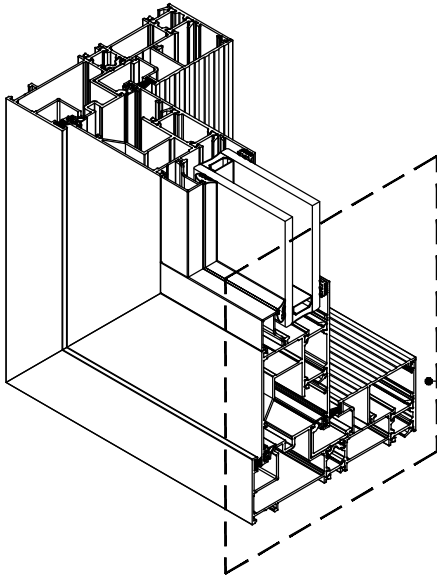

DETAY-5
DETAIL-5

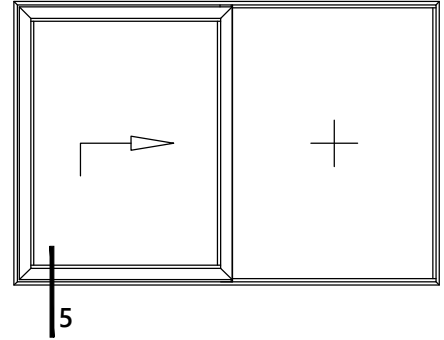

ÖLÇEK : 1/1
Scale : 1/1

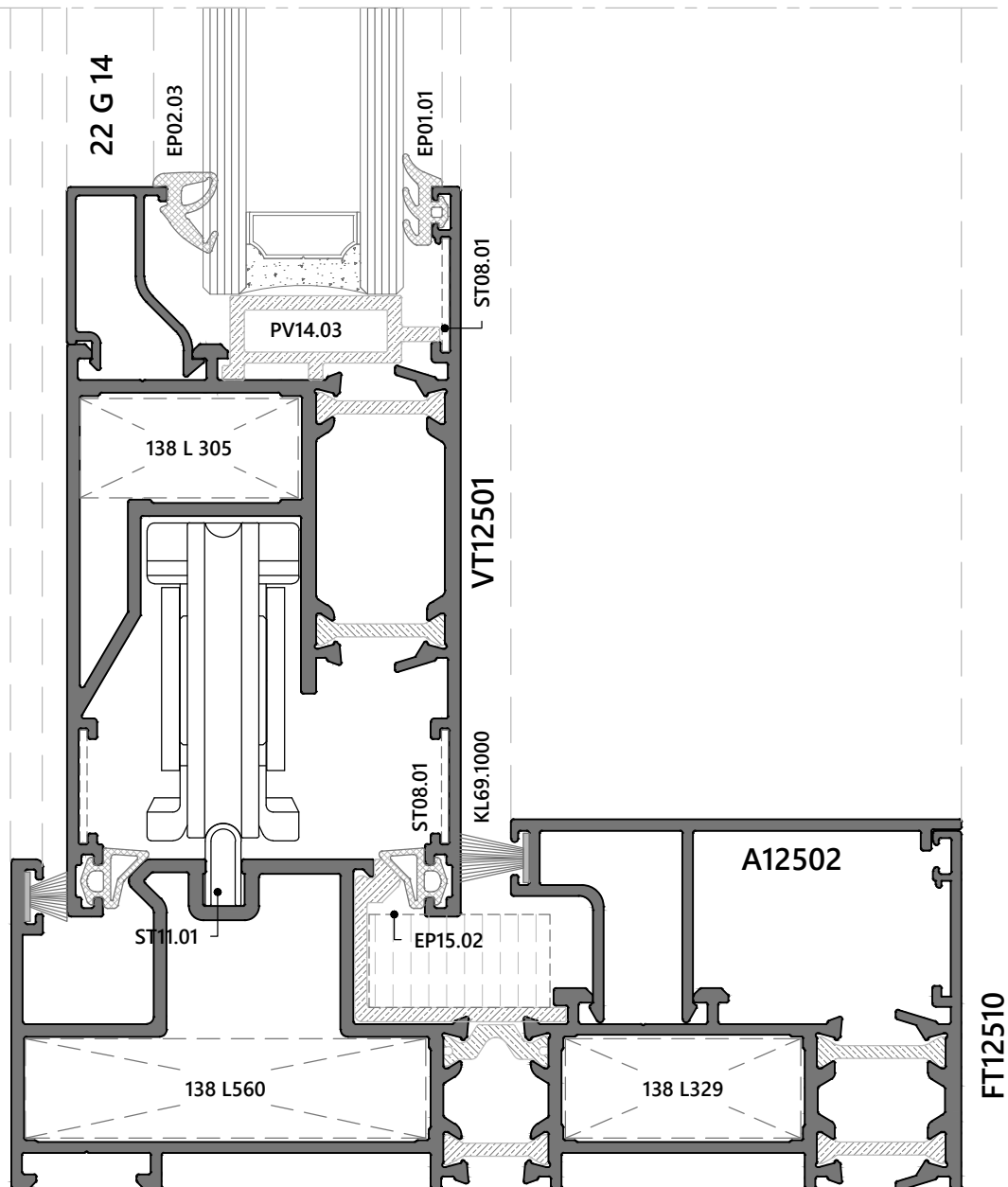

DETAY - 5a
DETAIL - 5a

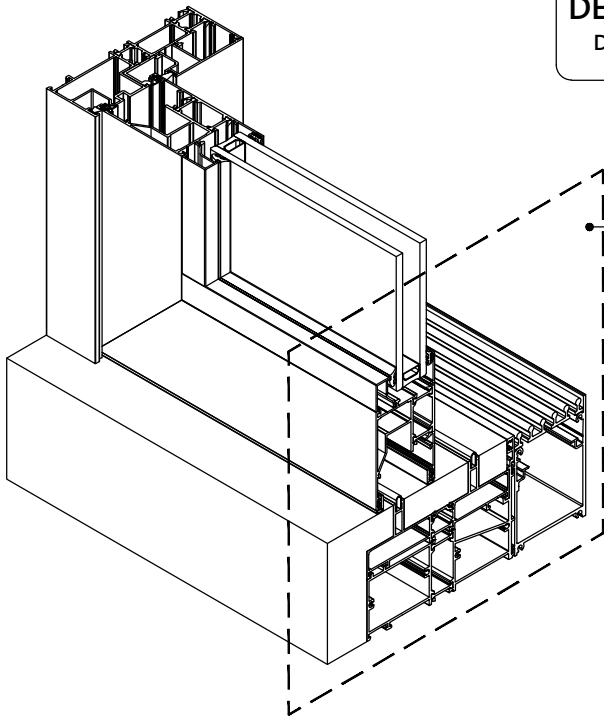

DETAY-5a
DETAIL-5a

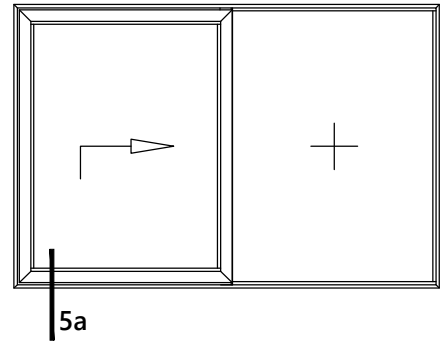

ÖLÇEK : 1/1
Scale : 1/1

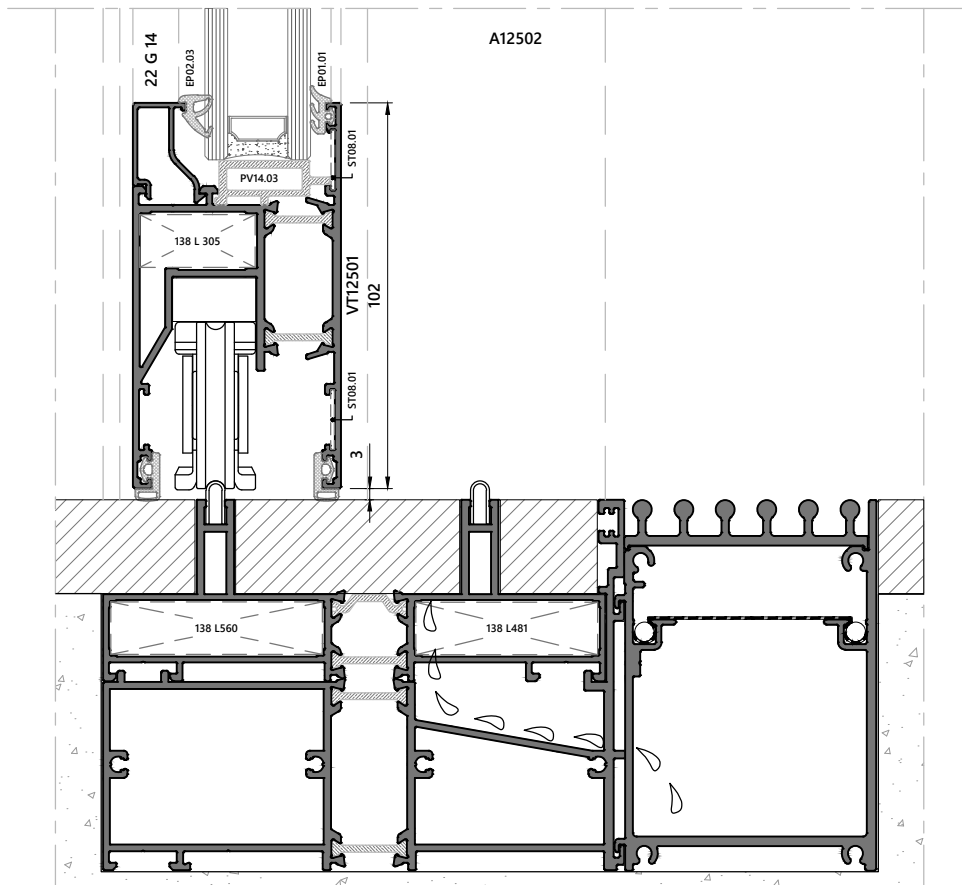
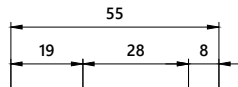

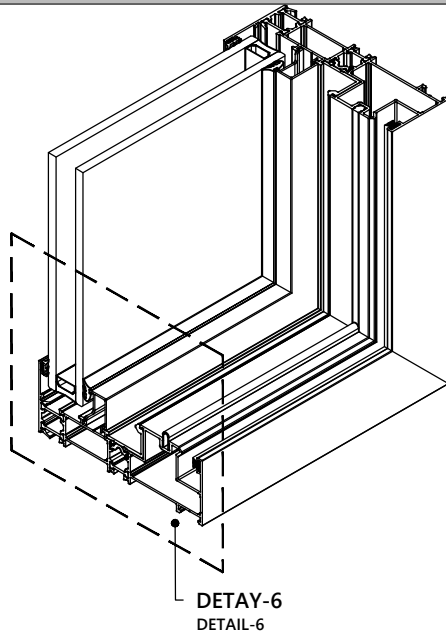

DETAY - 6
DETAIL - 6

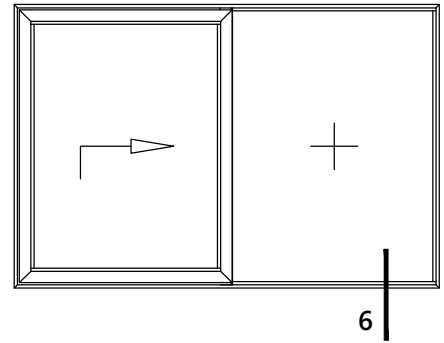

ÖLÇEK : 1/1
Scale : 1/1

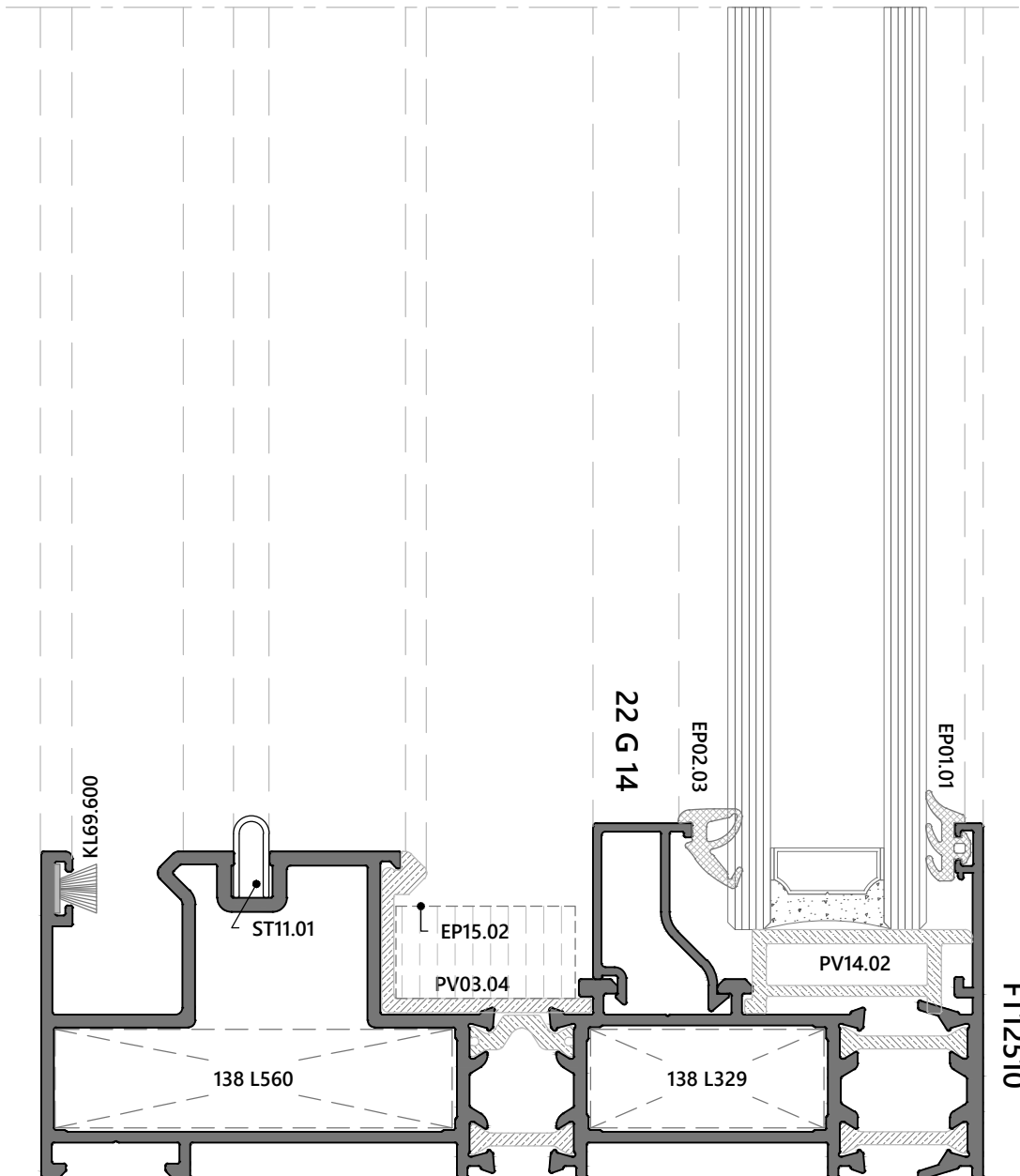

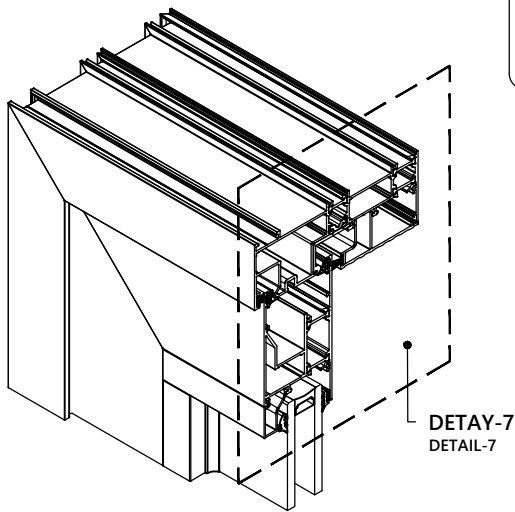

DETAY - 7
DETAIL - 7

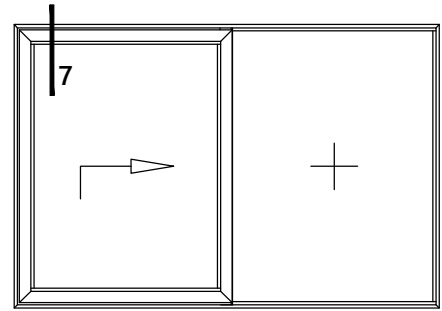

ÖLÇEK : 1/1
Scale : 1/1

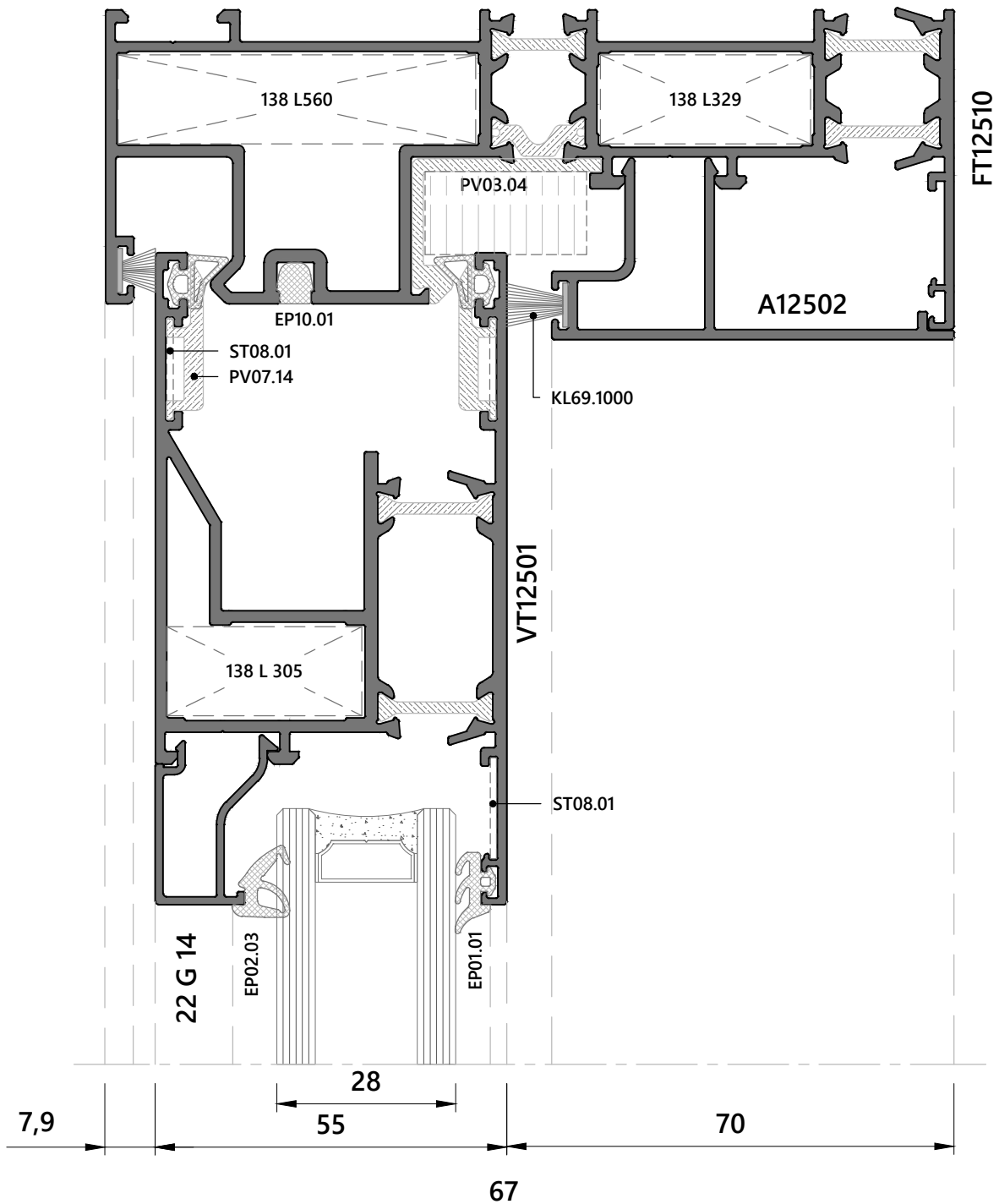

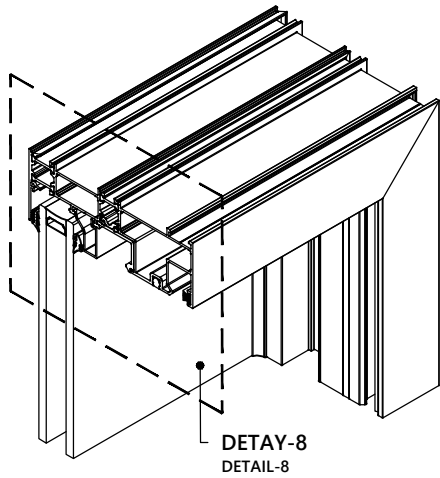

DETAY - 8
DETAIL - 8

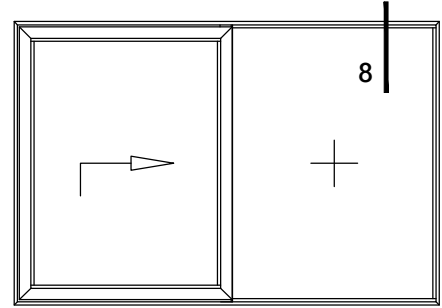

ÖLÇEK : 1/1
Scale : 1/1

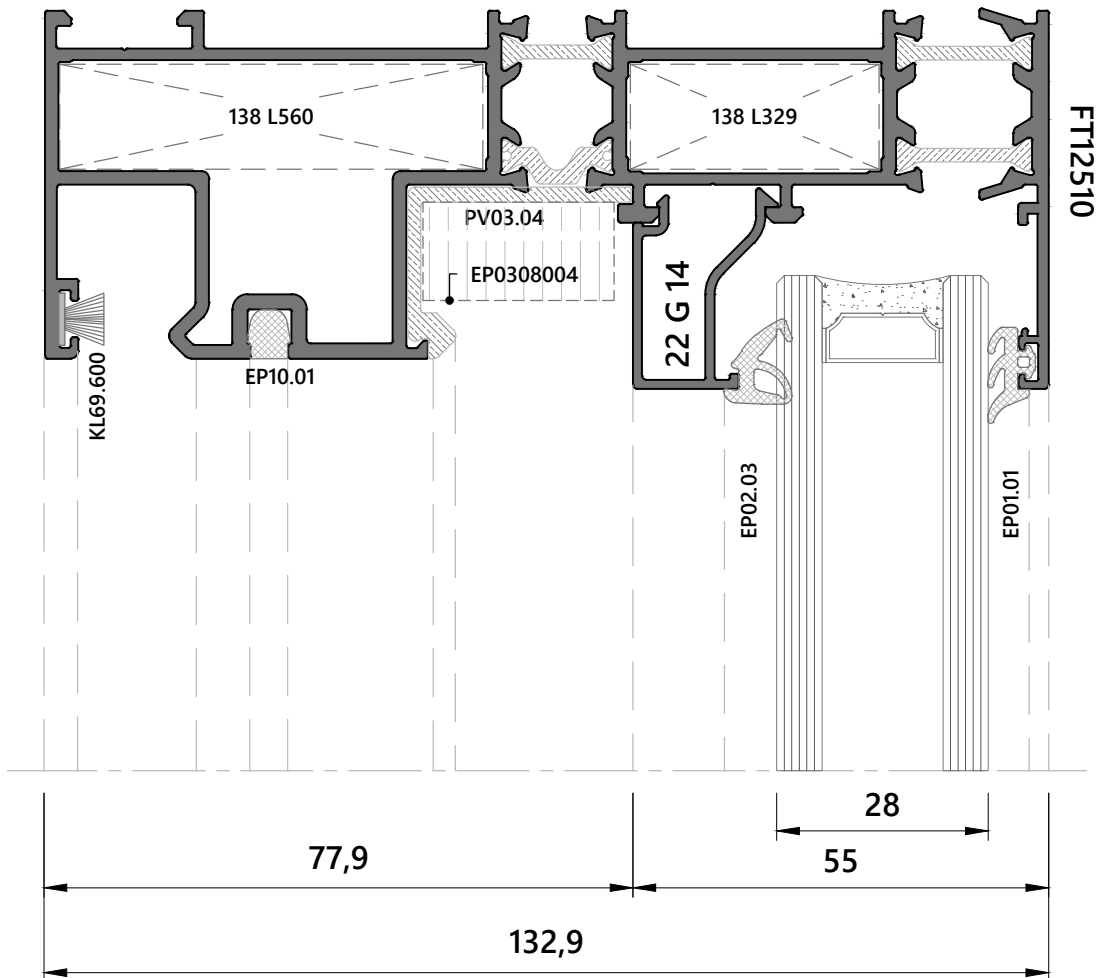

DETAY - 9
DETAIL - 9

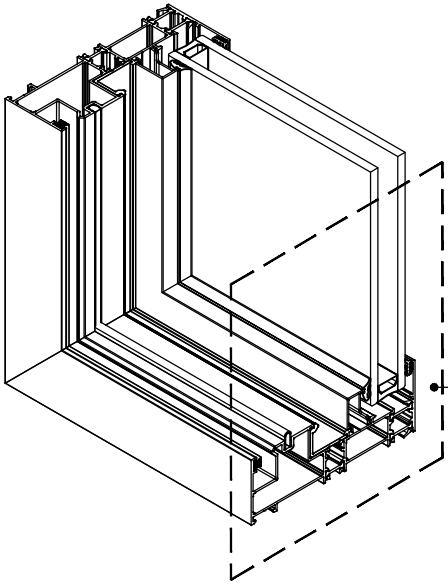

DETAY-9
DETAIL-9

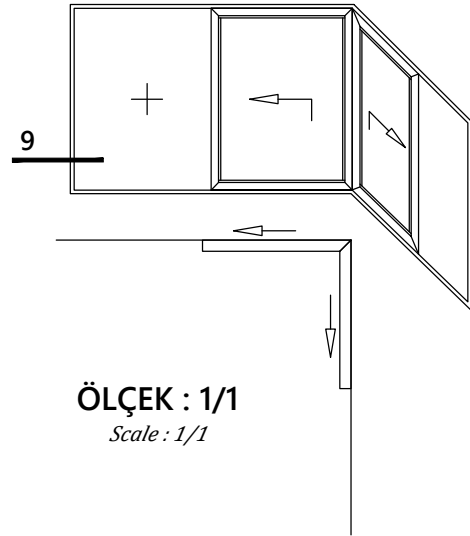

ÖLÇEK : 1/1
Scale : 1/1

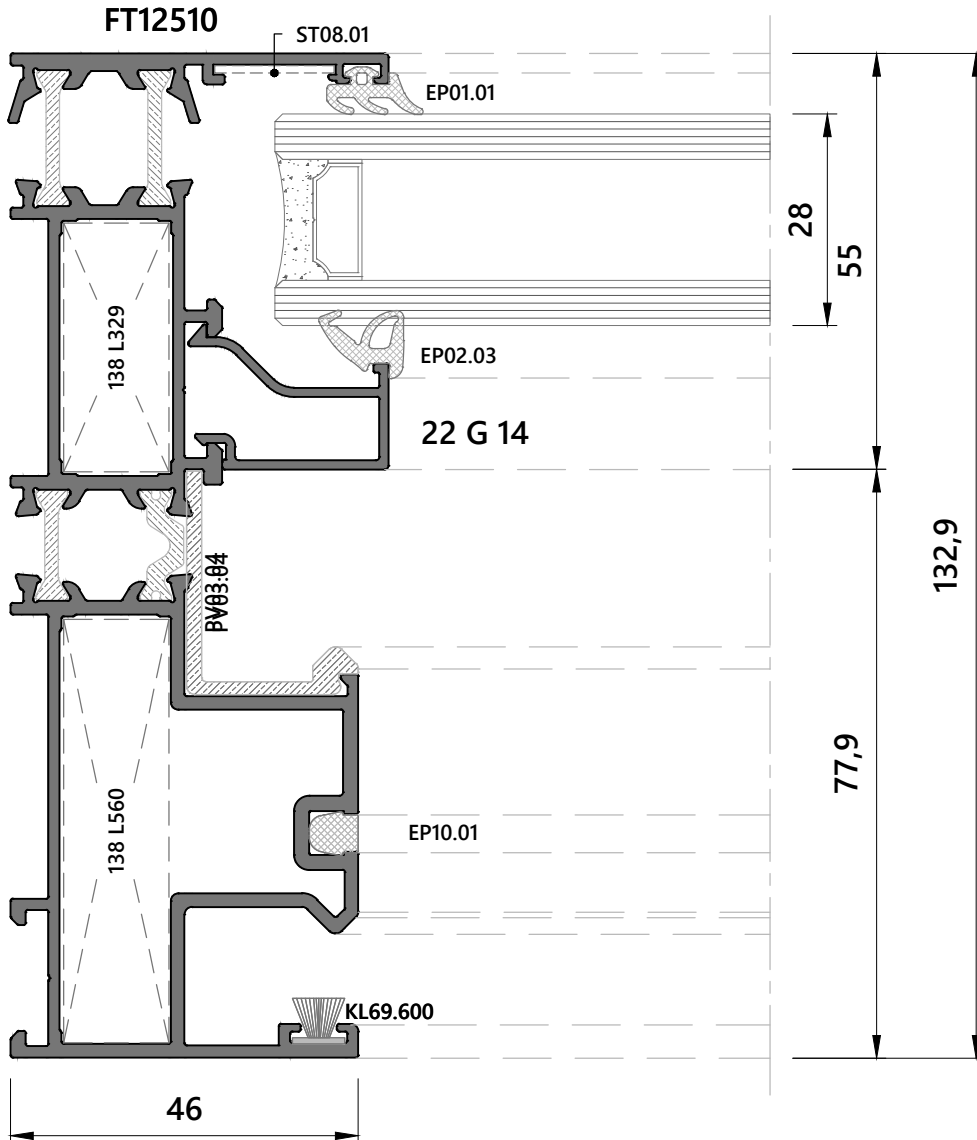

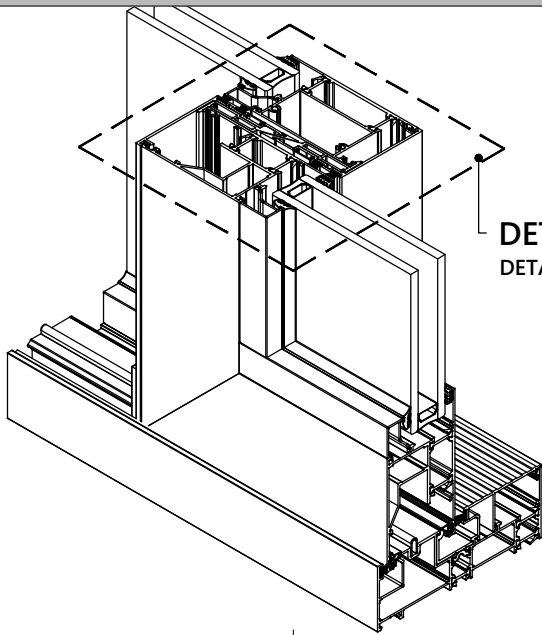

DETAY - 10
DETAIL - 10

DETAY - 10
DETAIL - 10

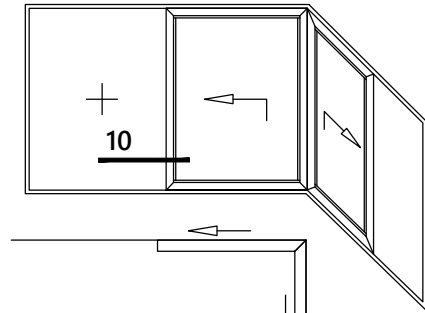

ÖLÇEK : 1/1
Scale : 1/1

102

MT12502

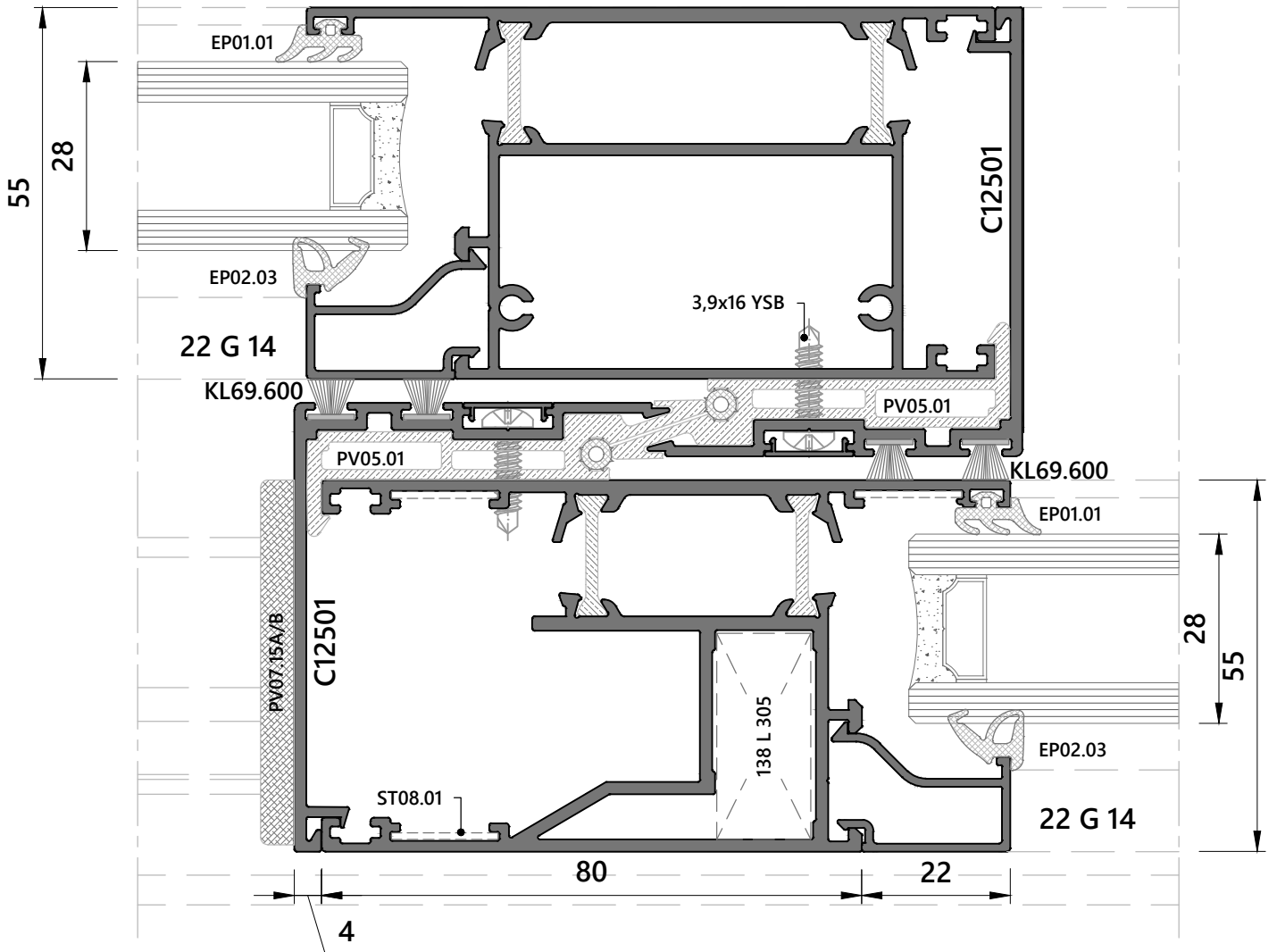

DETAY - 11
DETAIL - 11

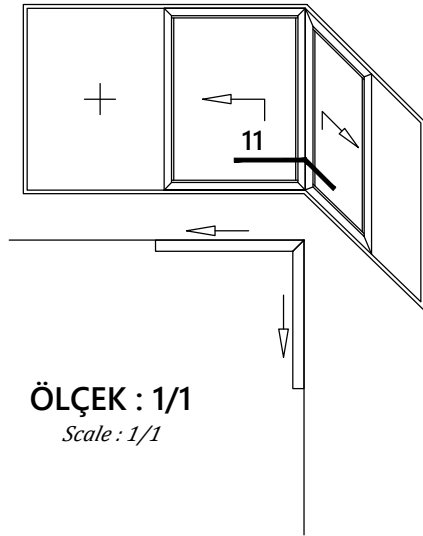
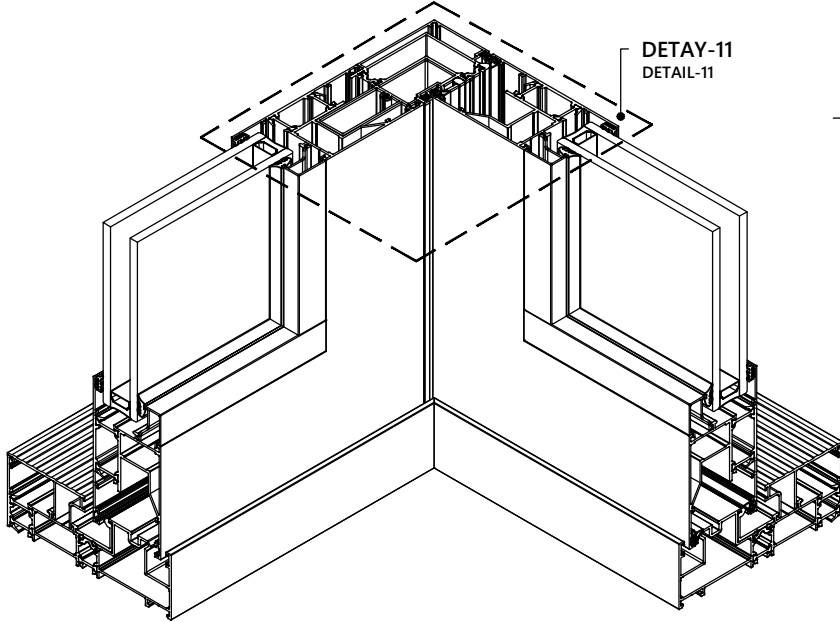

ÖLÇEK : 1/1
Scale : 1/1

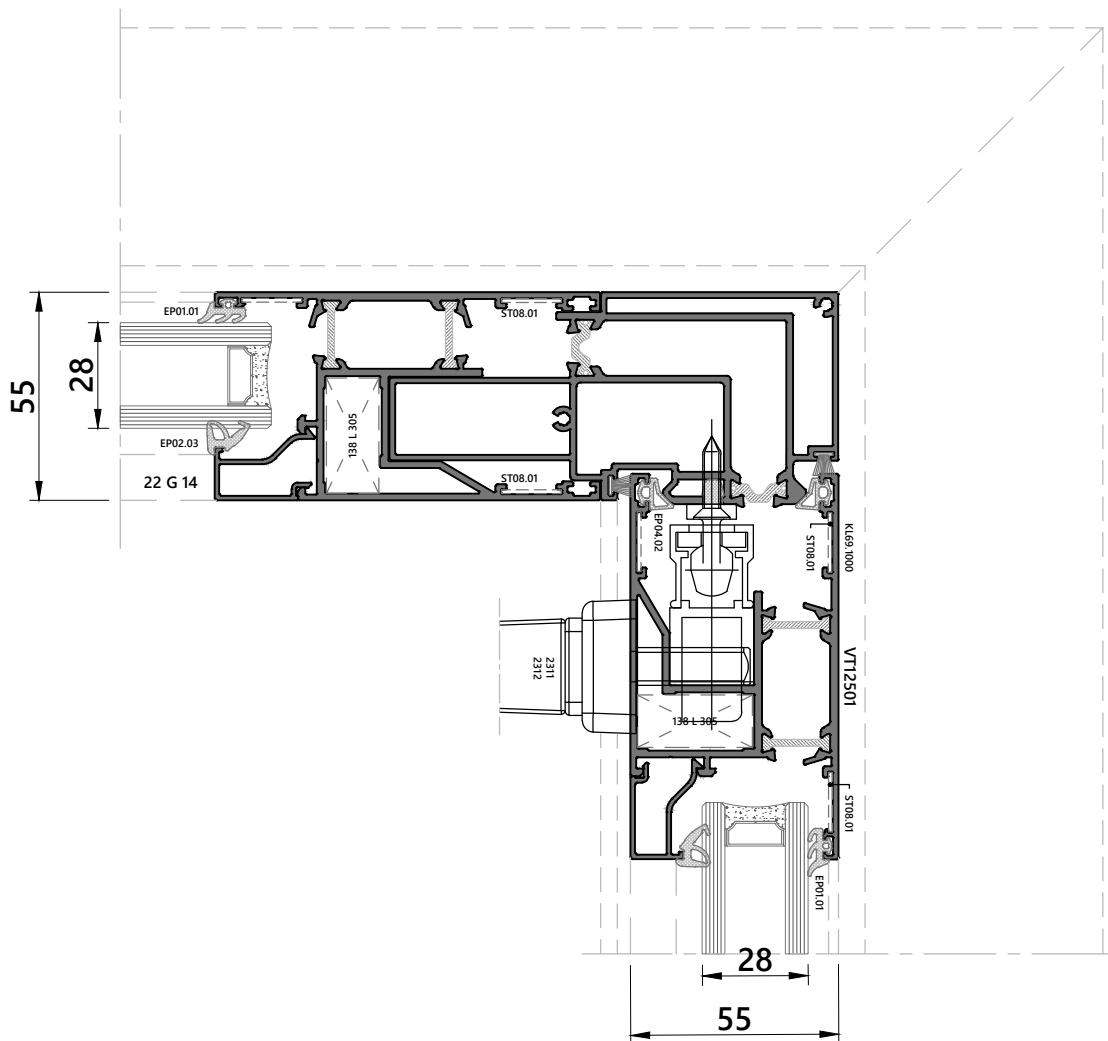

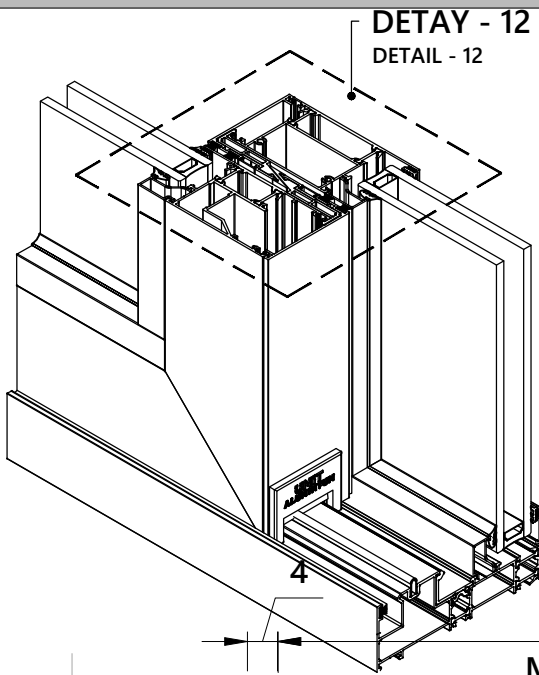

DETAIL - 12
DETAIL - 12

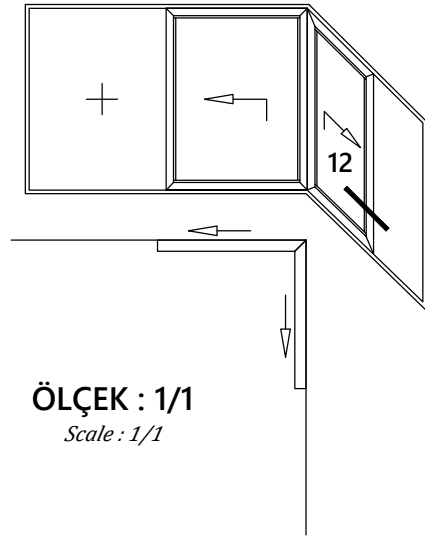

ÖLÇEK : 1/1
Scale : 1/1

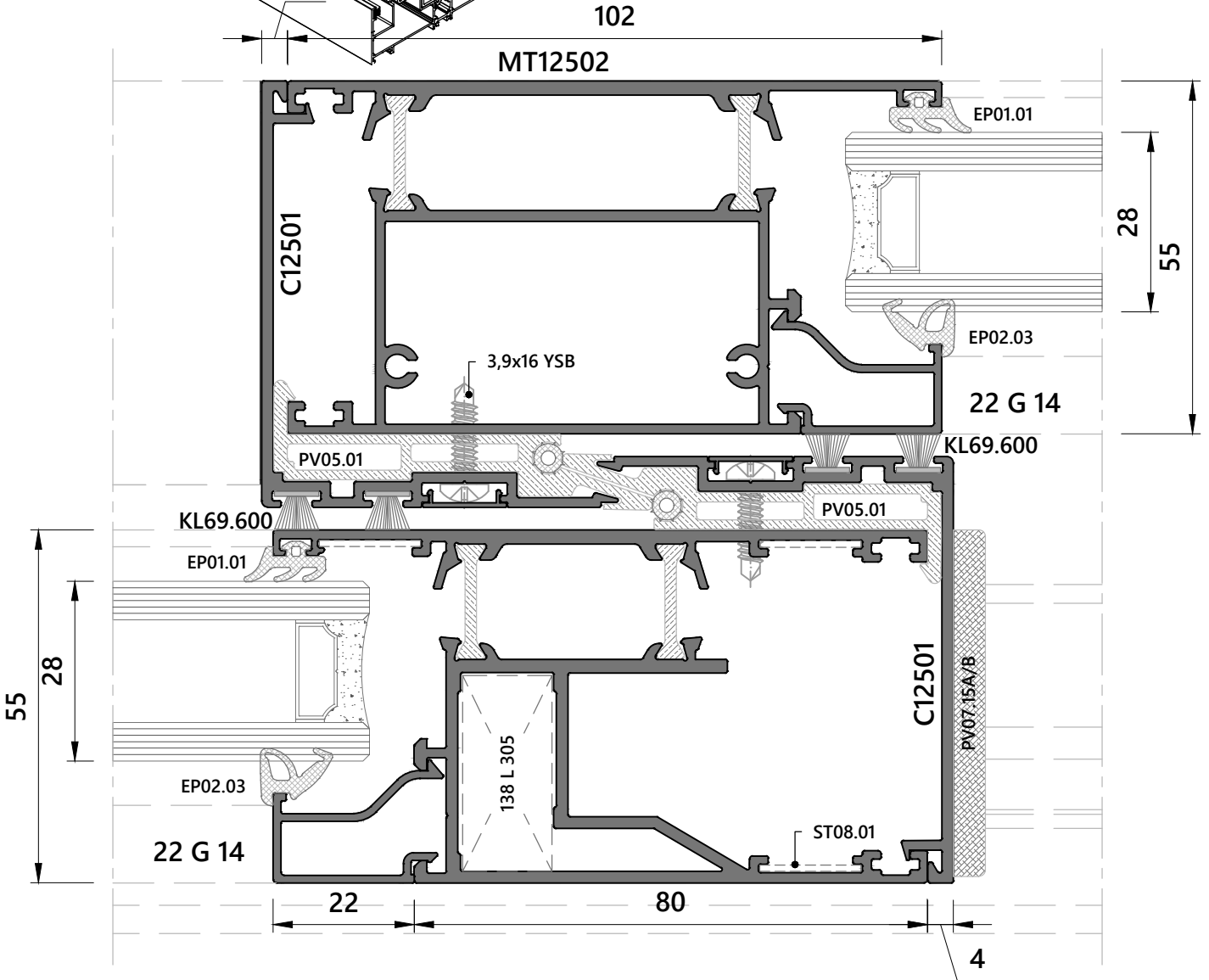

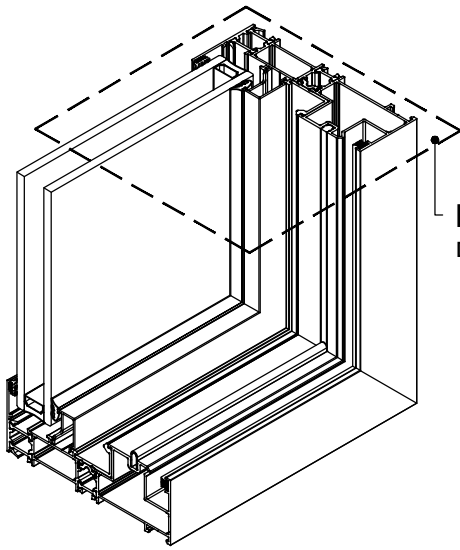

DETAY - 13
DETAIL - 13

DETAY - 13
DETAIL - 13

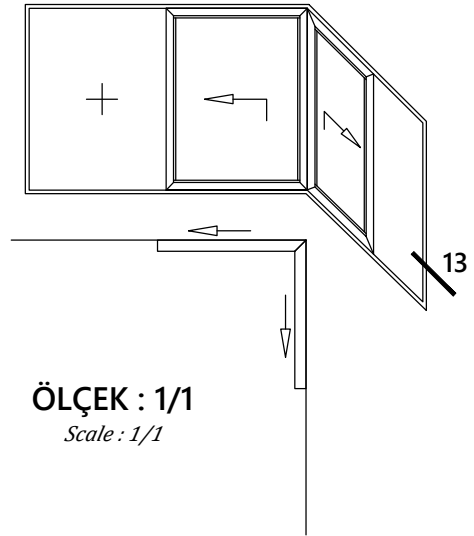

ÖLÇEK : 1/1
Scale : 1/1

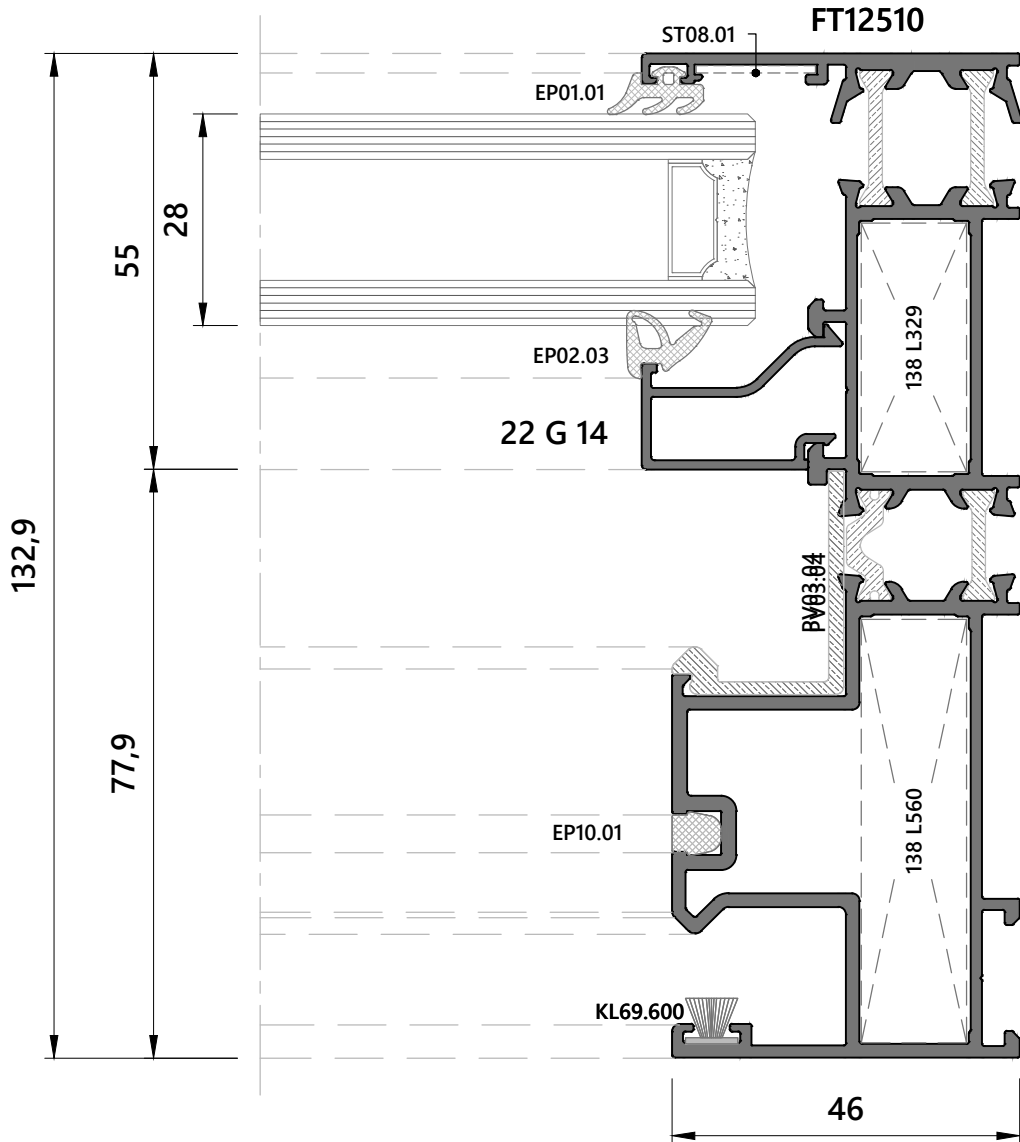

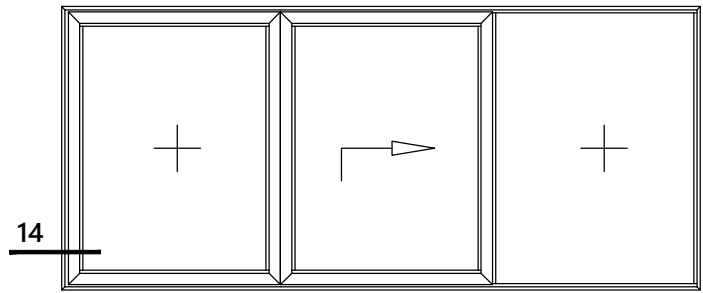
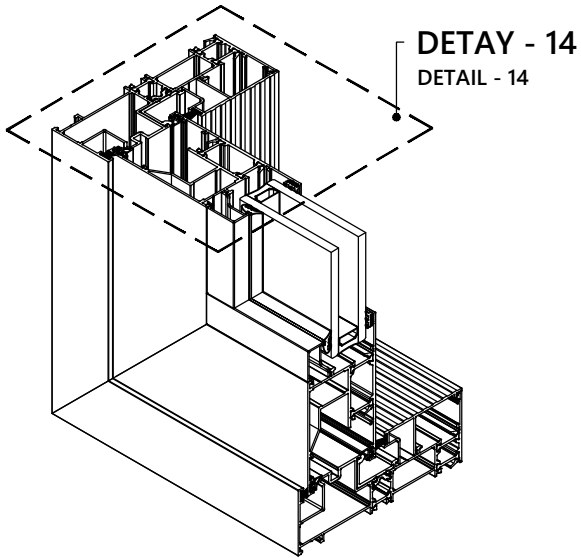

ÖLÇEK : 1/1
Scale : 1/1

DETAIL - 14
DETAIL - 14

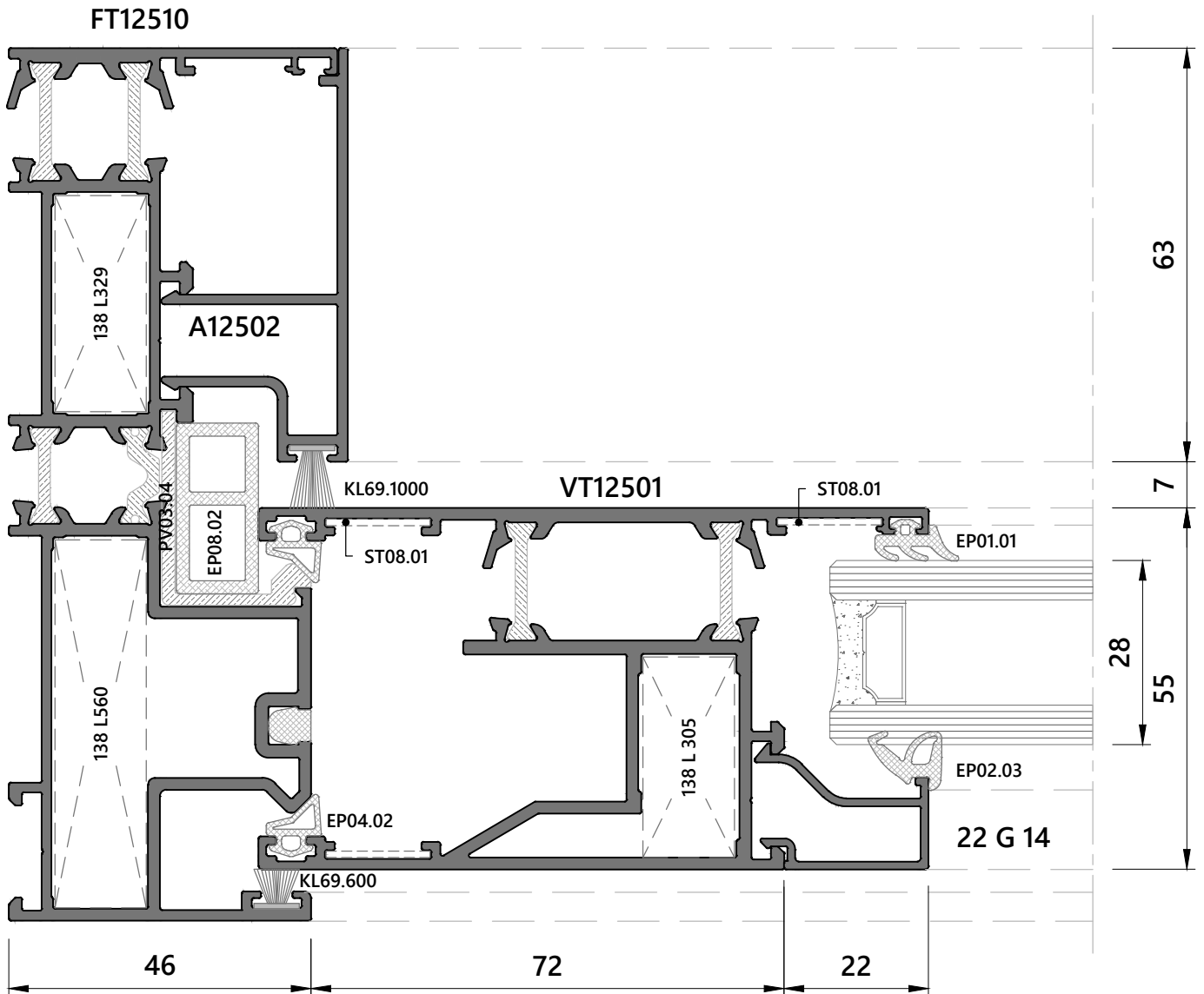

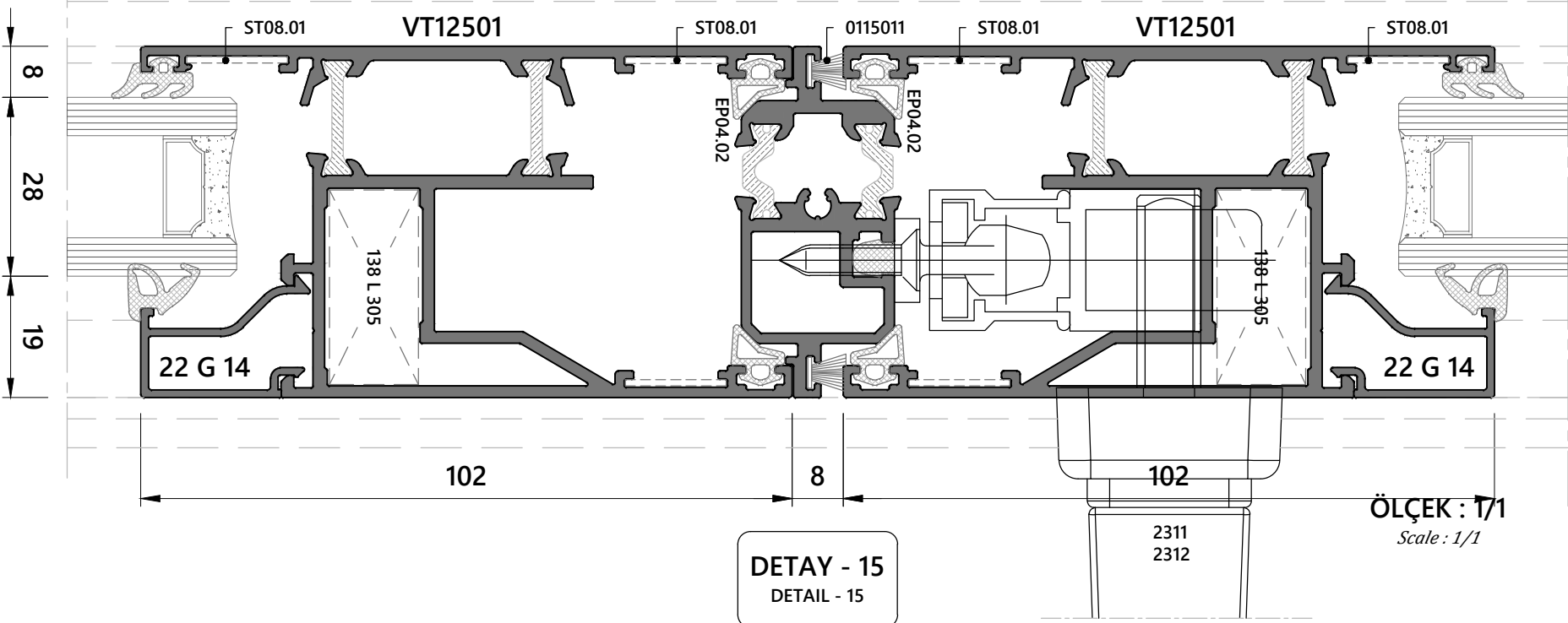
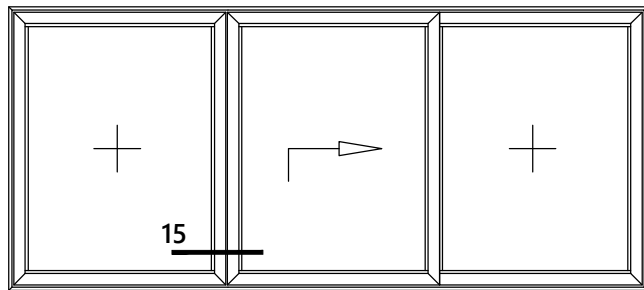

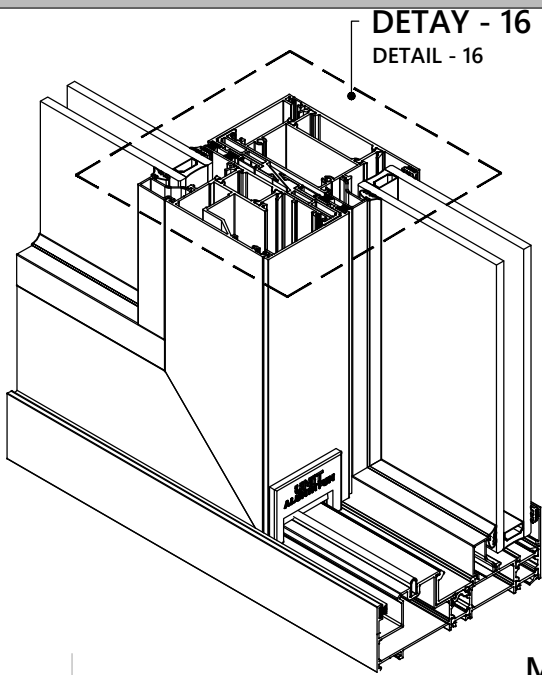

DETAY - 16
DETAIL - 16

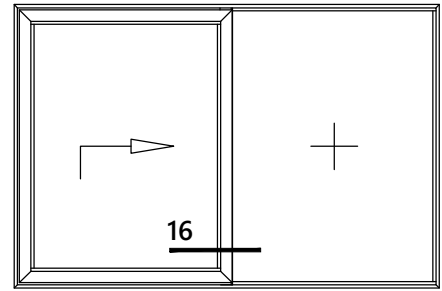

ÖLÇEK : 1/1
Scale : 1/1

MT12502

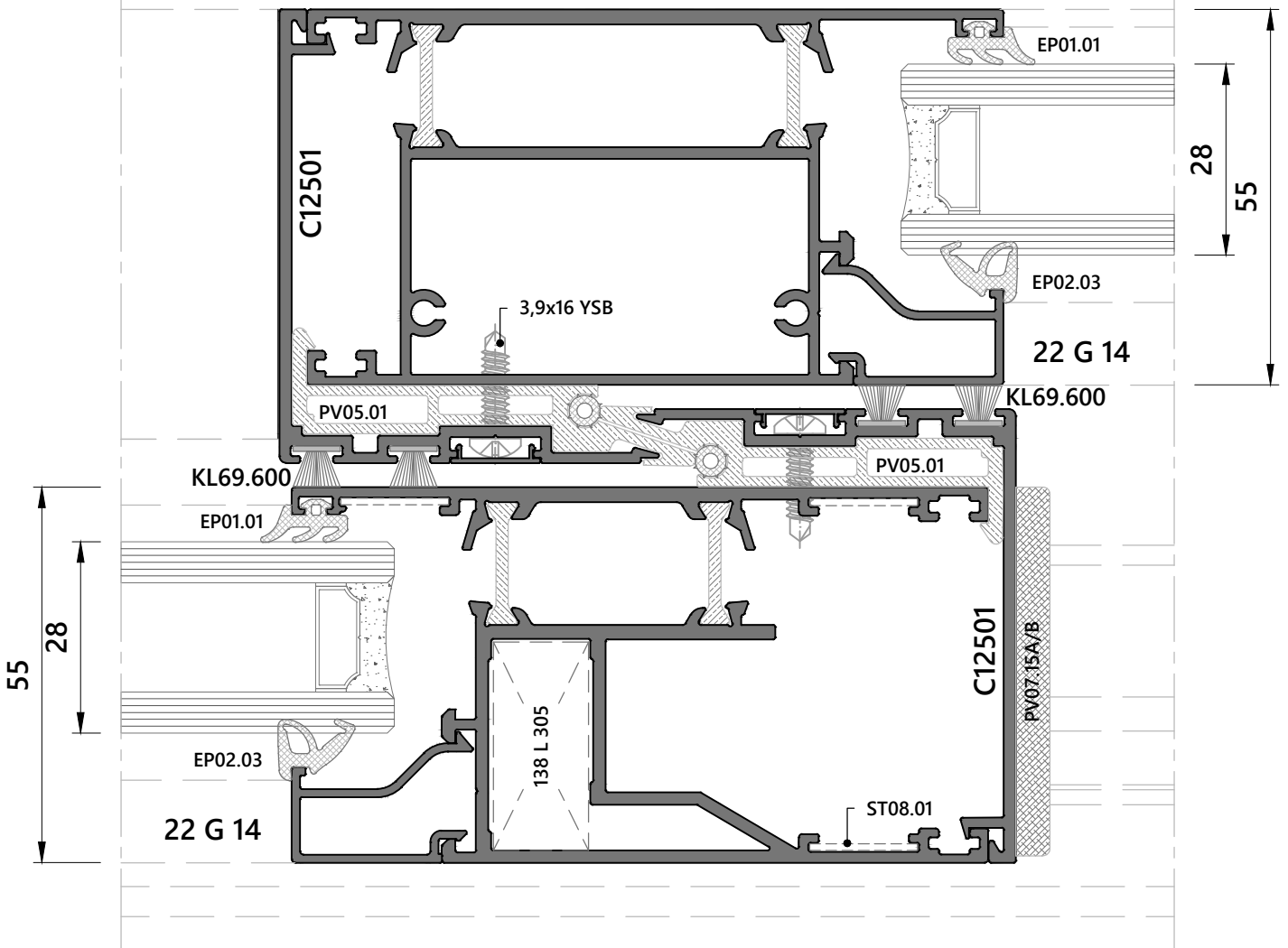

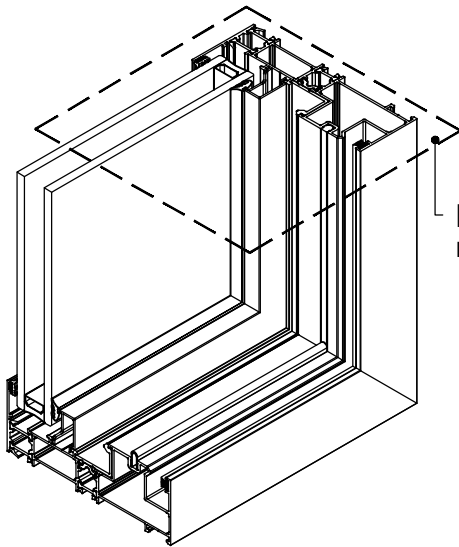

DETAY - 17
DETAIL - 17

DETAY - 17
DETAIL - 17

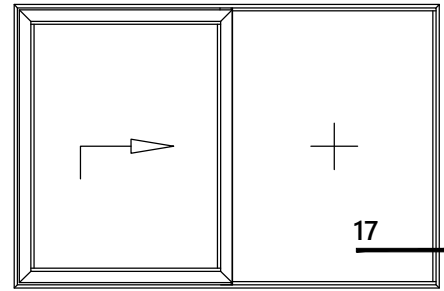

ÖLÇEK : 1/1
Scale : 1/1

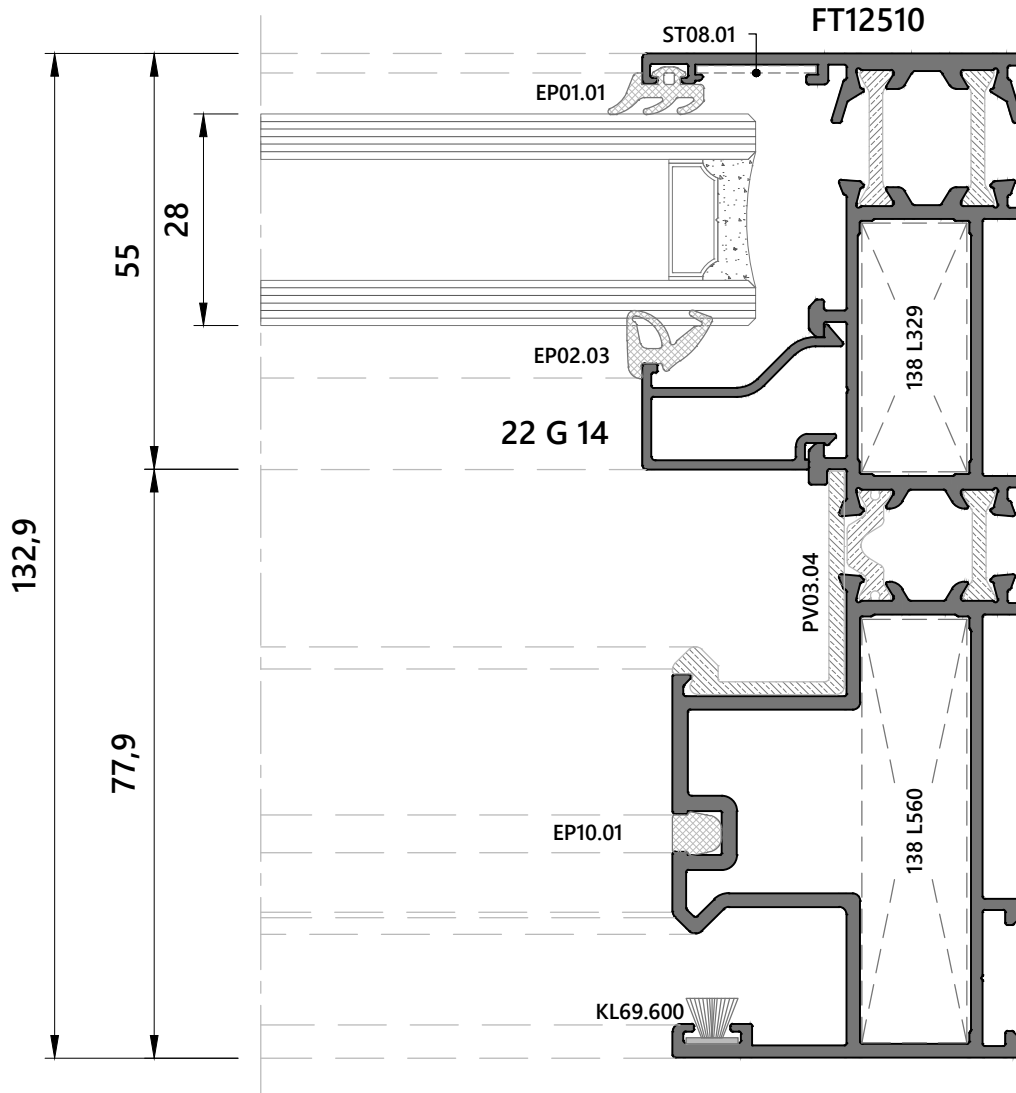

KLASİK SÜRME AÇILIM TİPLERİ

SLIDING TYPES OF OPENING

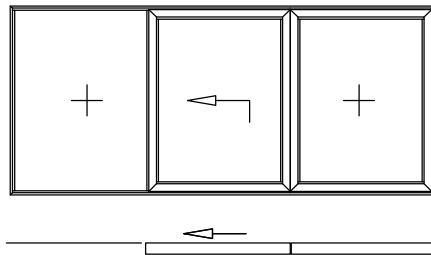
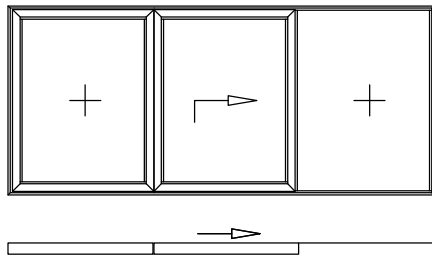
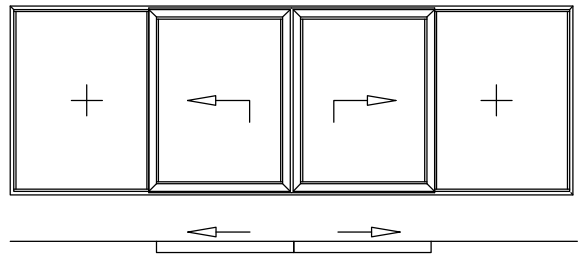
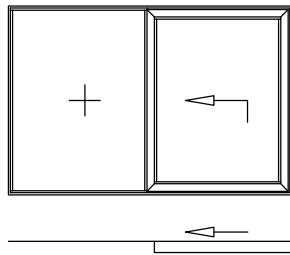
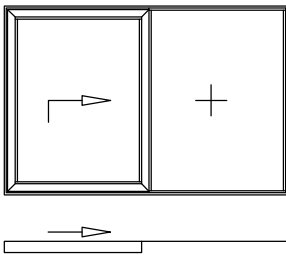

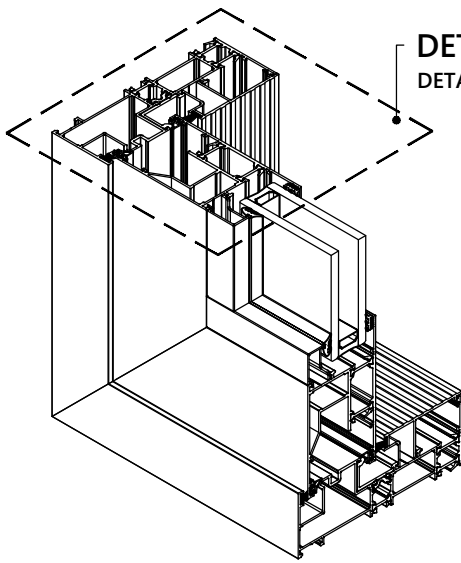

DETAY - 1
DETAIL - 1

DETAY - 1
DETAIL - 1

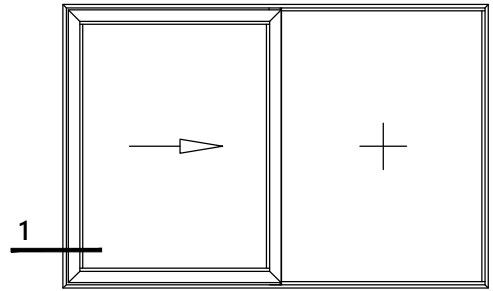

ÖLÇEK : 1/1
Scale : 1/1

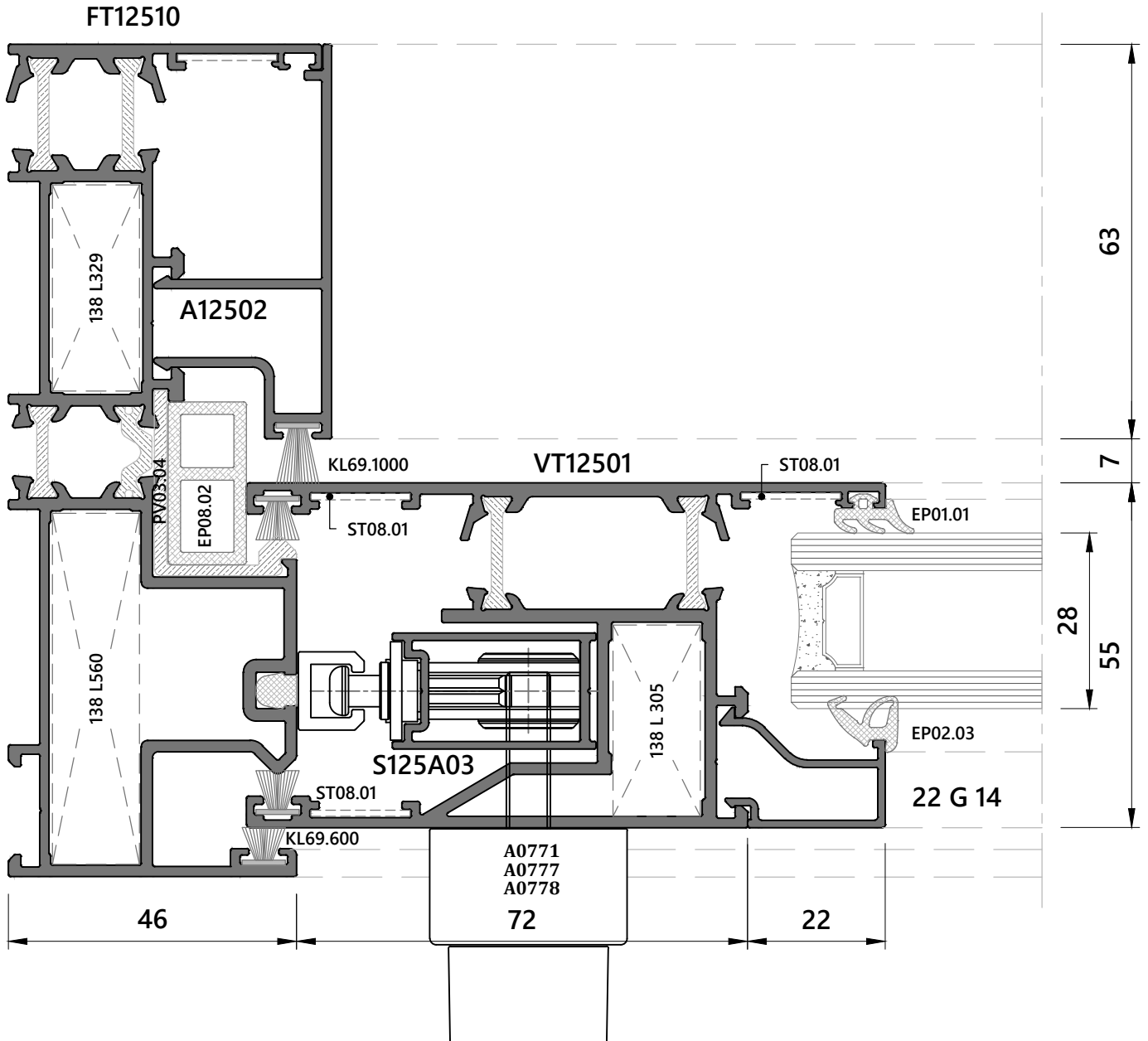

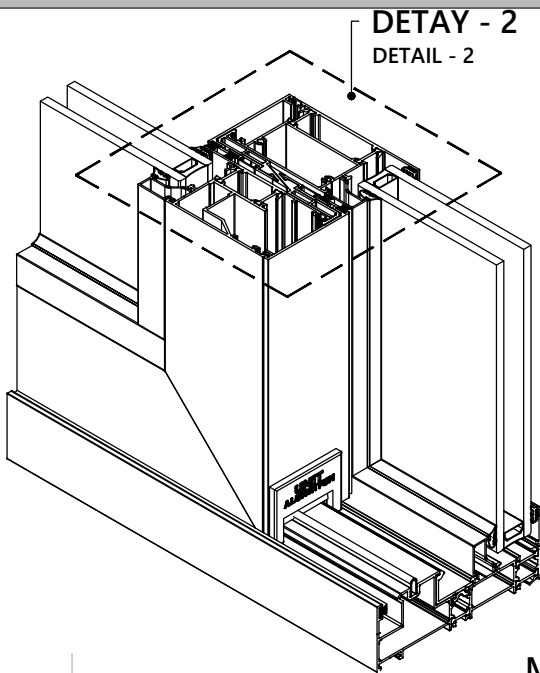

DETAY - 2
DETAIL - 2

DETAY - 2
DETAIL - 2

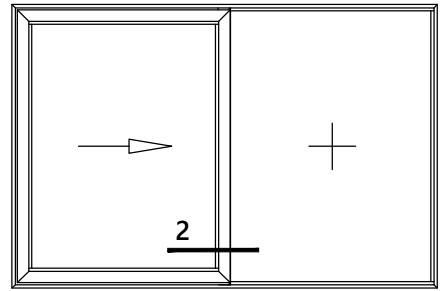

ÖLÇEK : 1/1
Scale : 1/1

MT12502

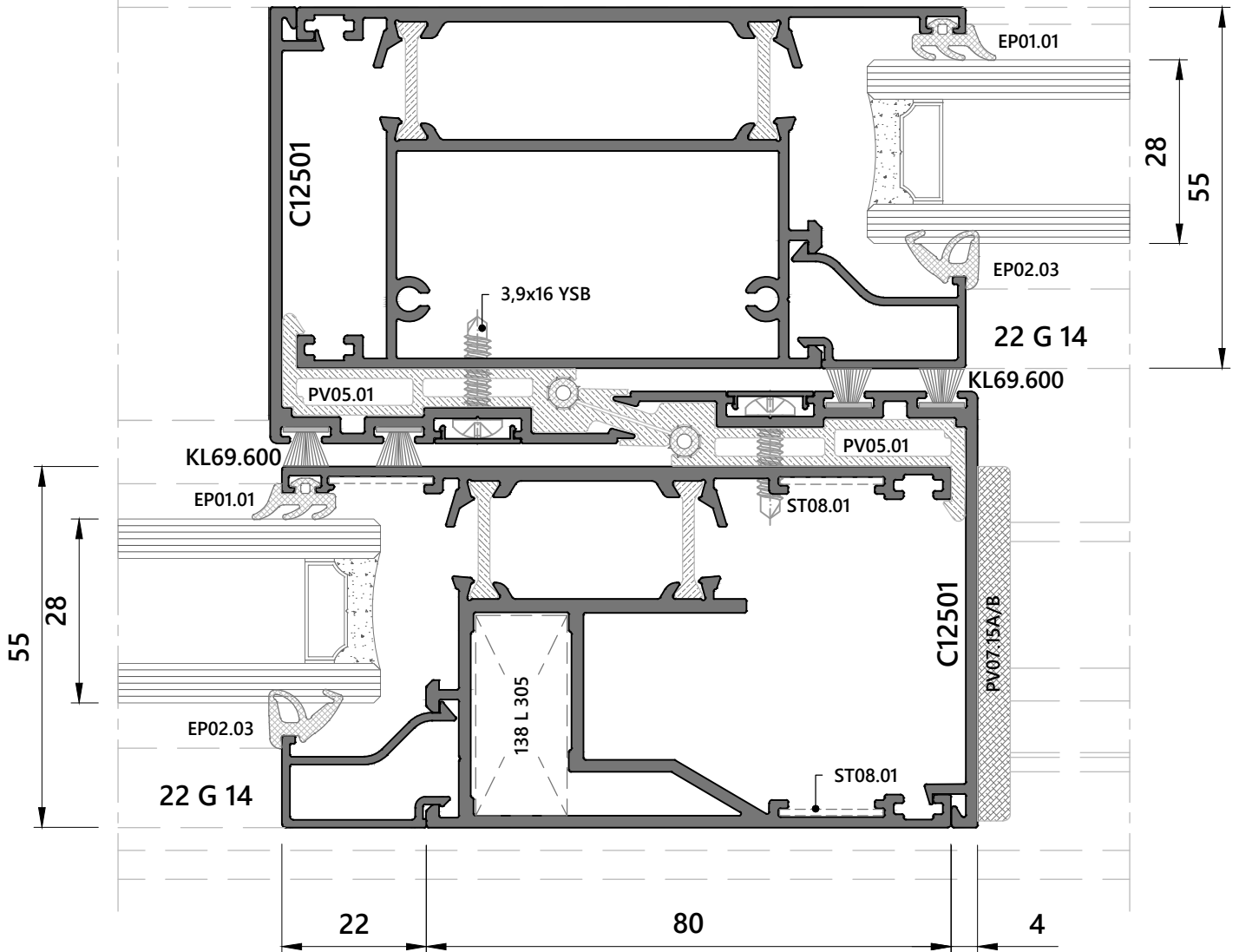

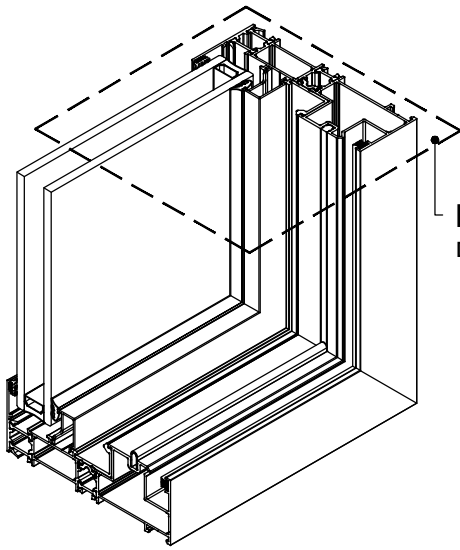

DETAY - 3
DETAIL - 3

DETAY - 3
DETAIL - 3

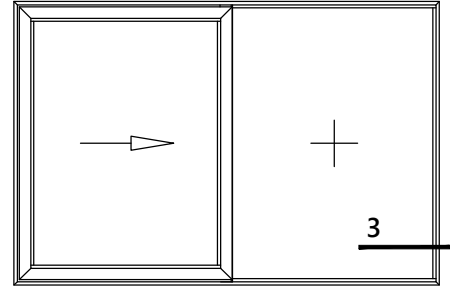

ÖLÇEK : 1/1
Scale : 1/1

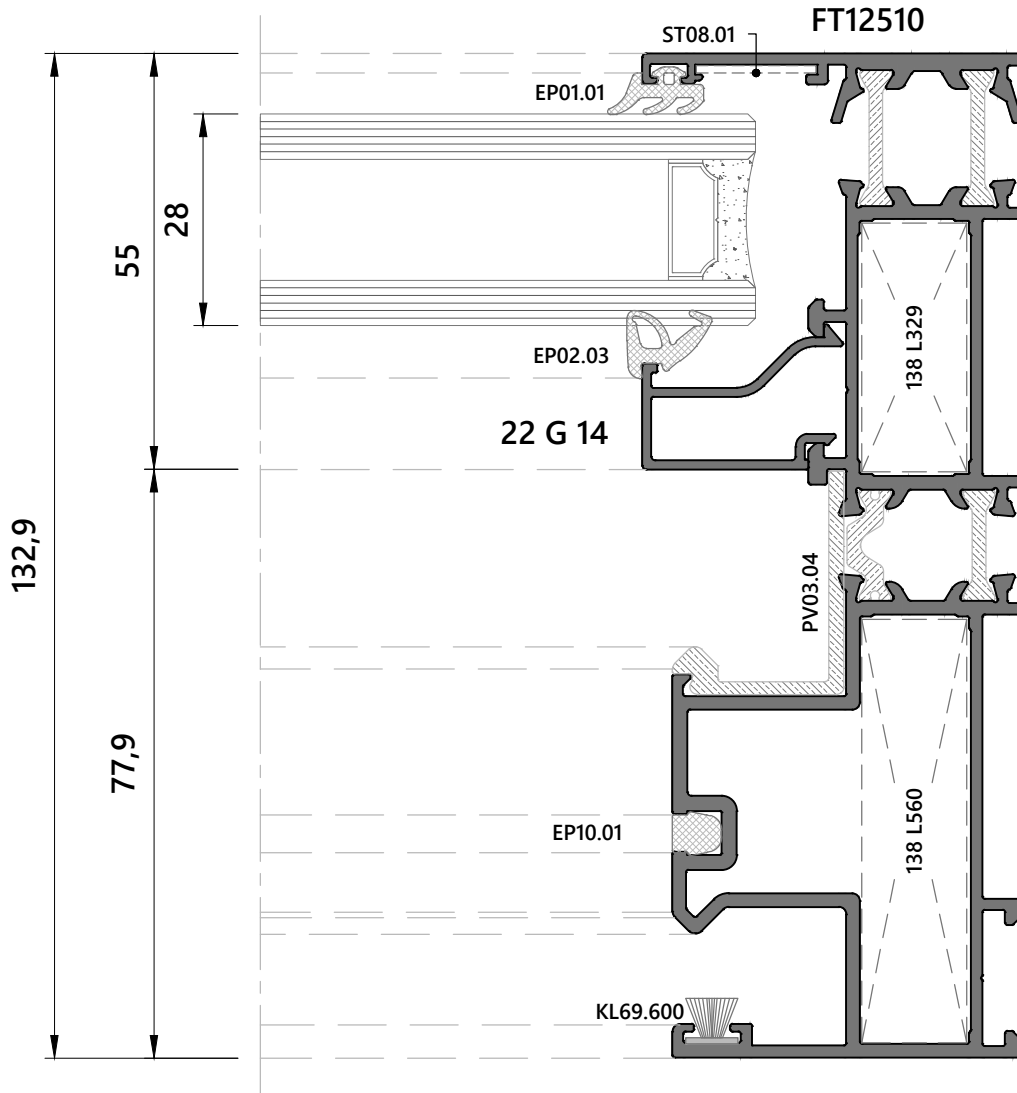

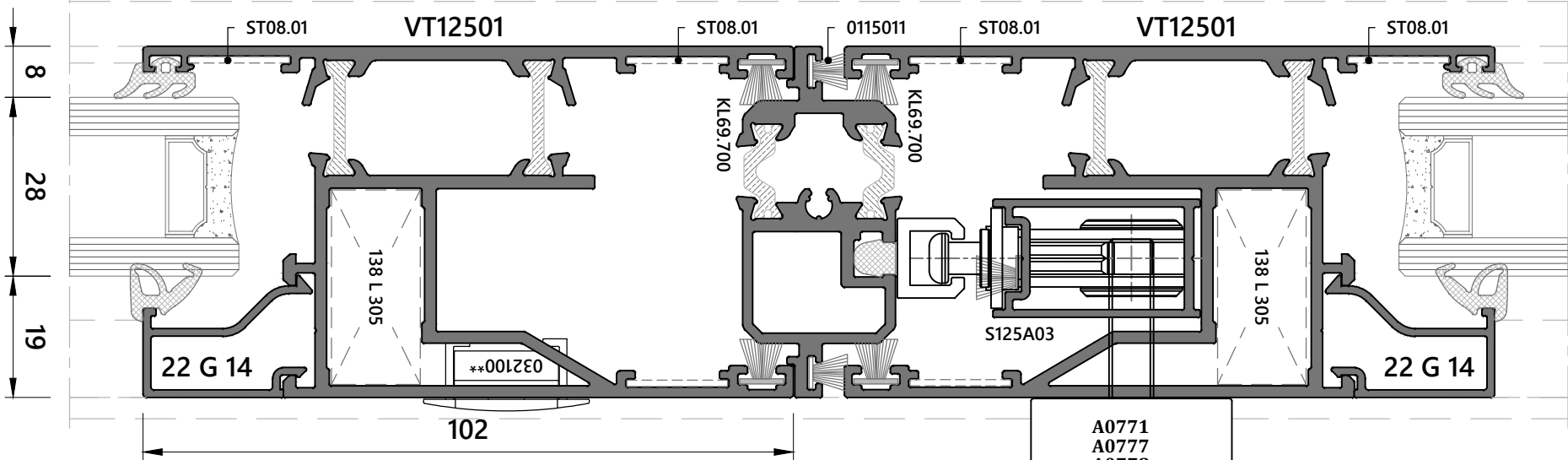
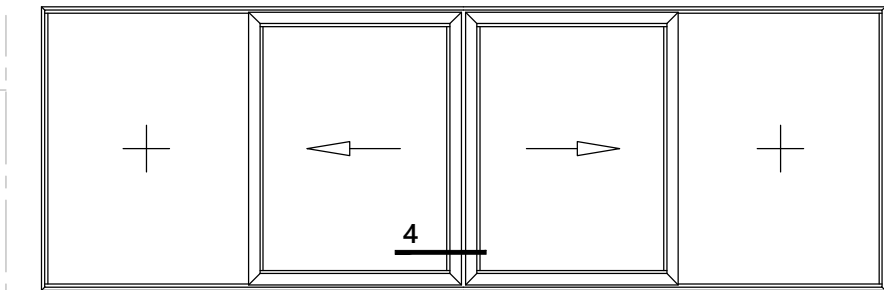

A0771
A0777
A0778

ÖLÇEK : 1/1
Scale : 1/1

DETAY - 5
DETAIL - 5

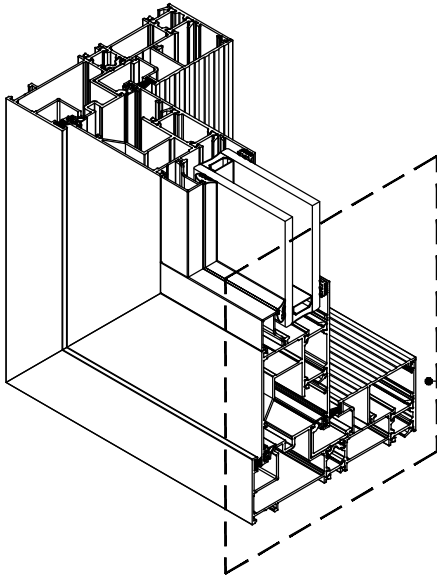

DETAY-5
DETAIL-5

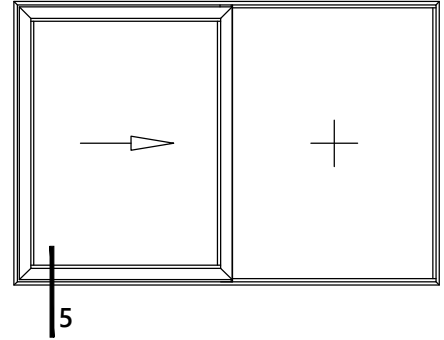

ÖLÇEK : 1/1
Scale : 1/1

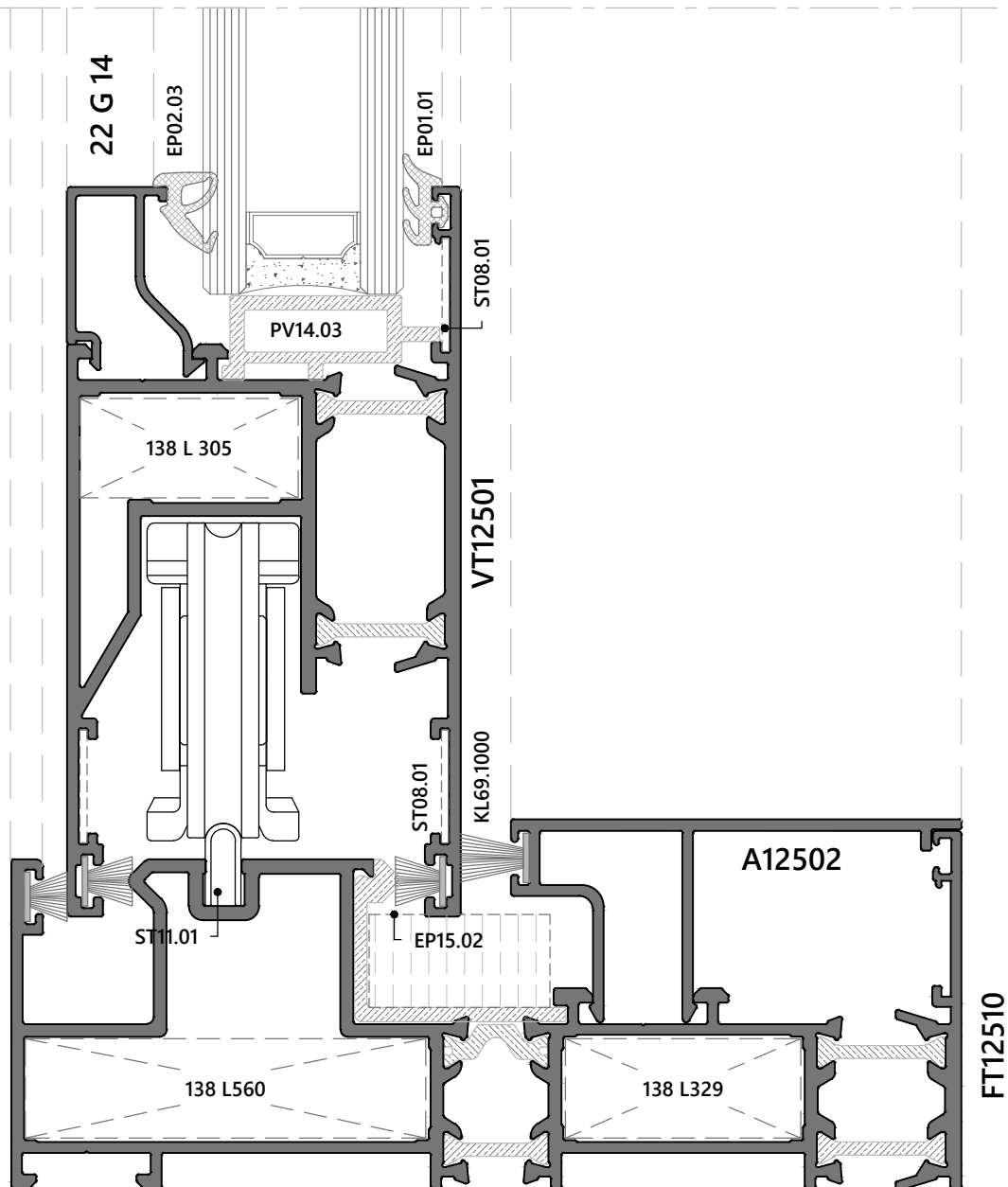

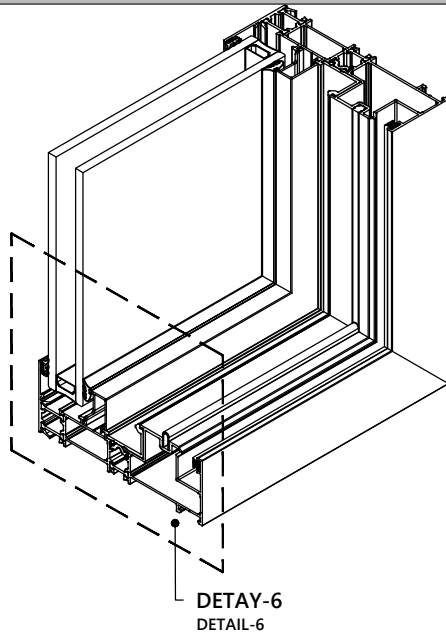

DETAY - 6
DETAIL - 6

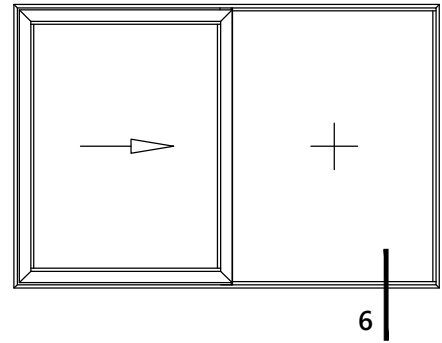

ÖLÇEK : 1/1
Scale : 1/1

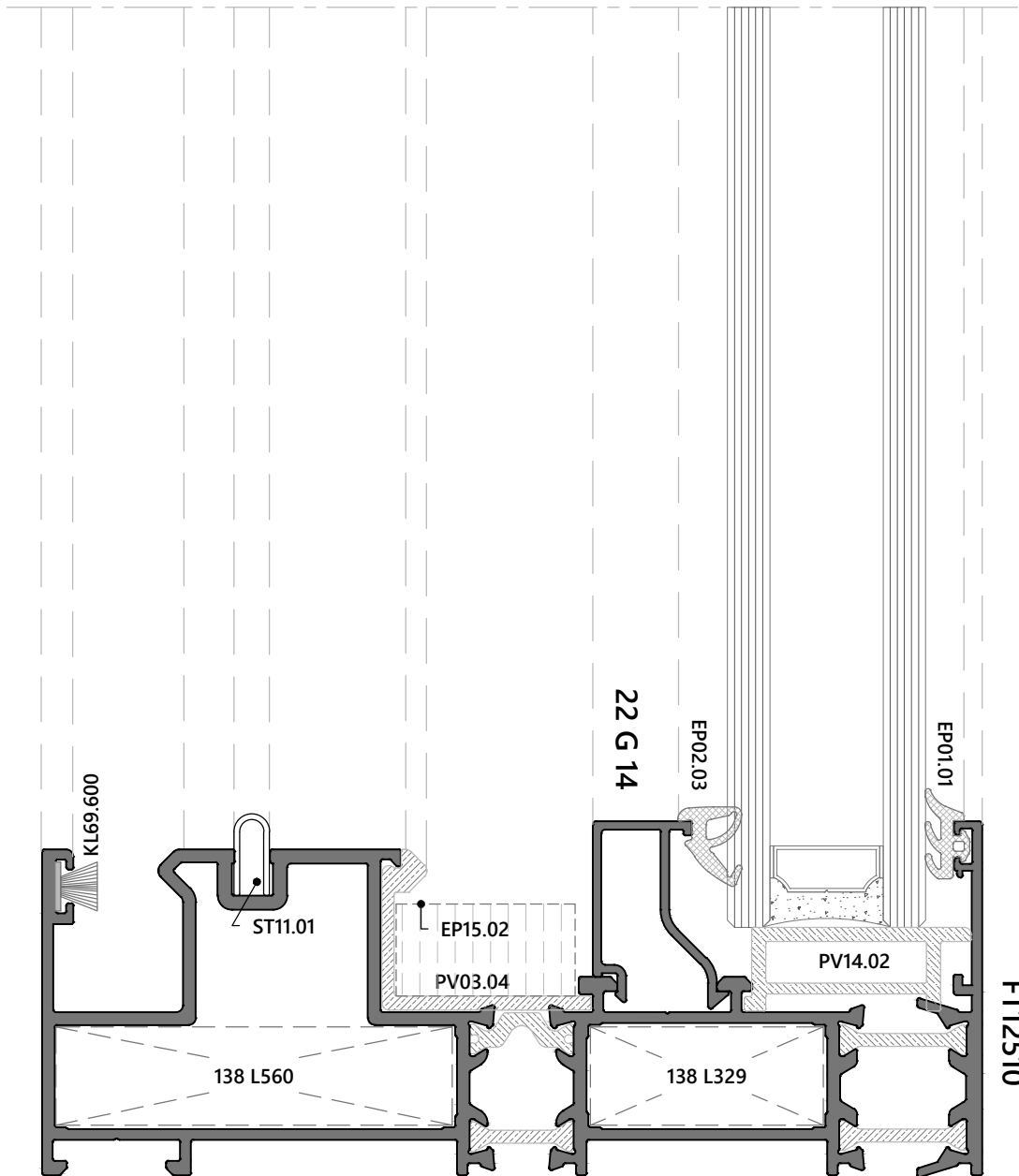

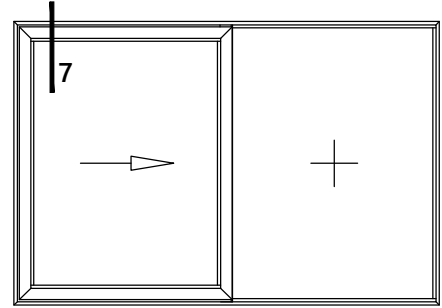
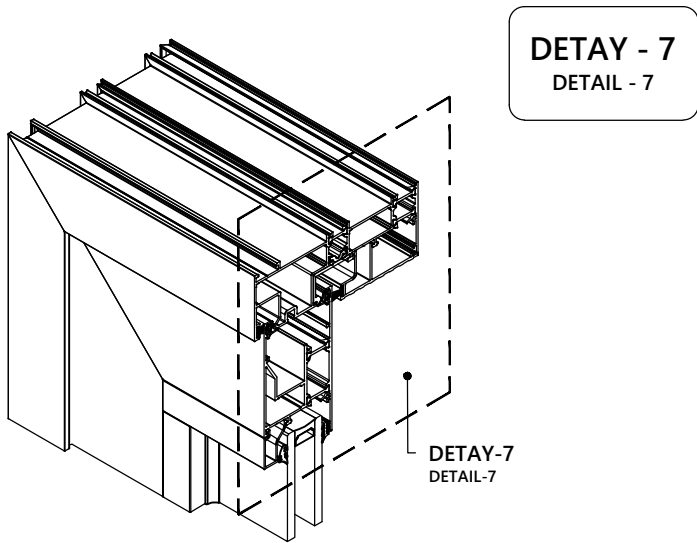

ÖLÇEK : 1/1
Scale : 1/1

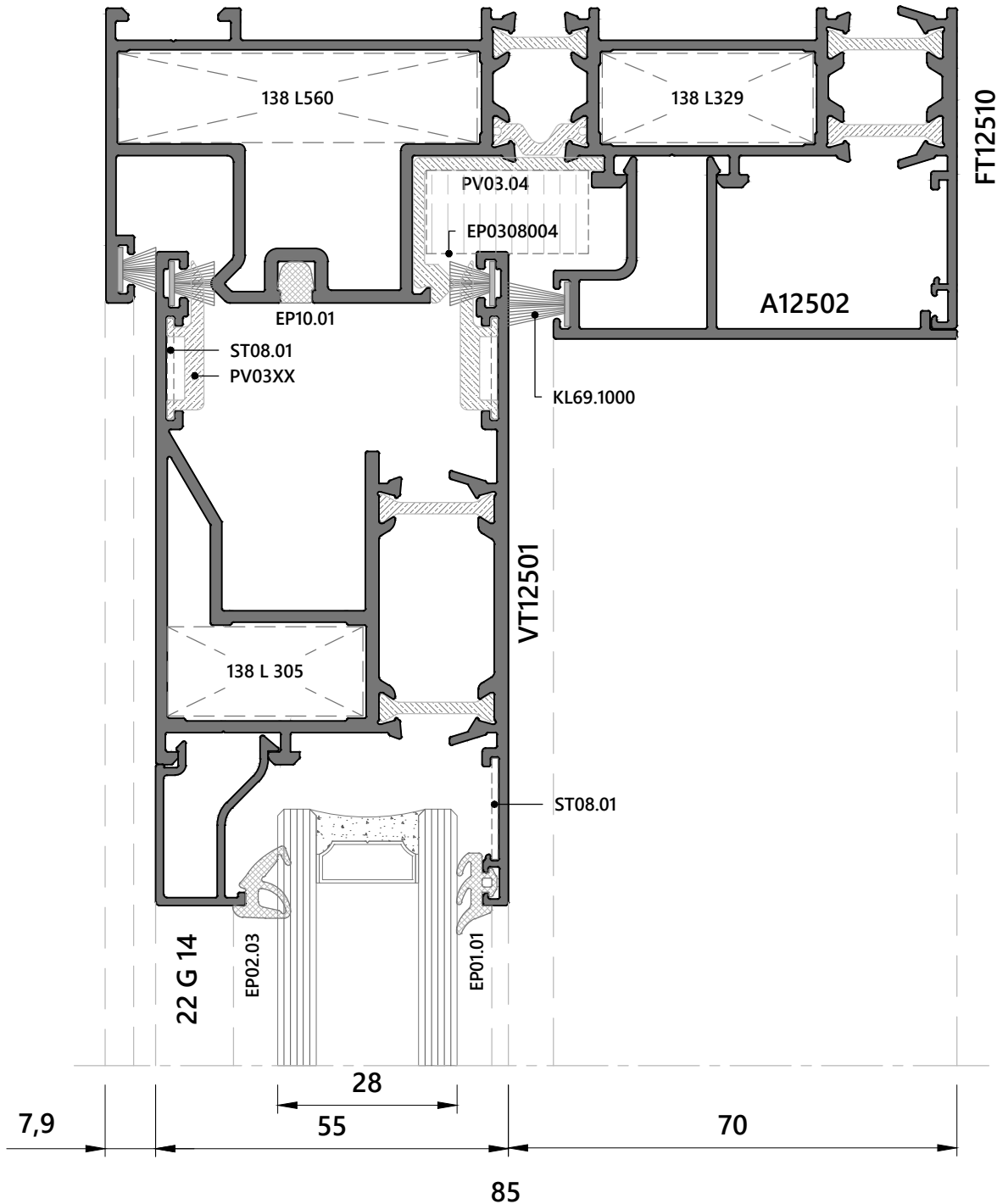

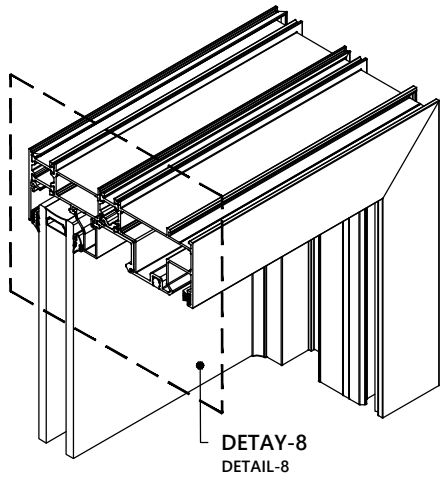

DETAY - 8
DETAIL - 8

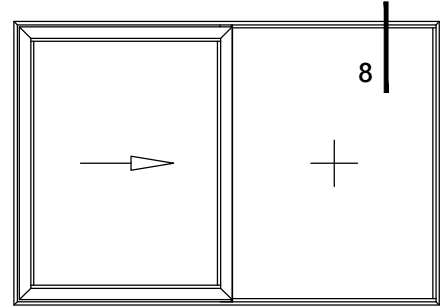

ÖLÇEK : 1/1
Scale : 1/1

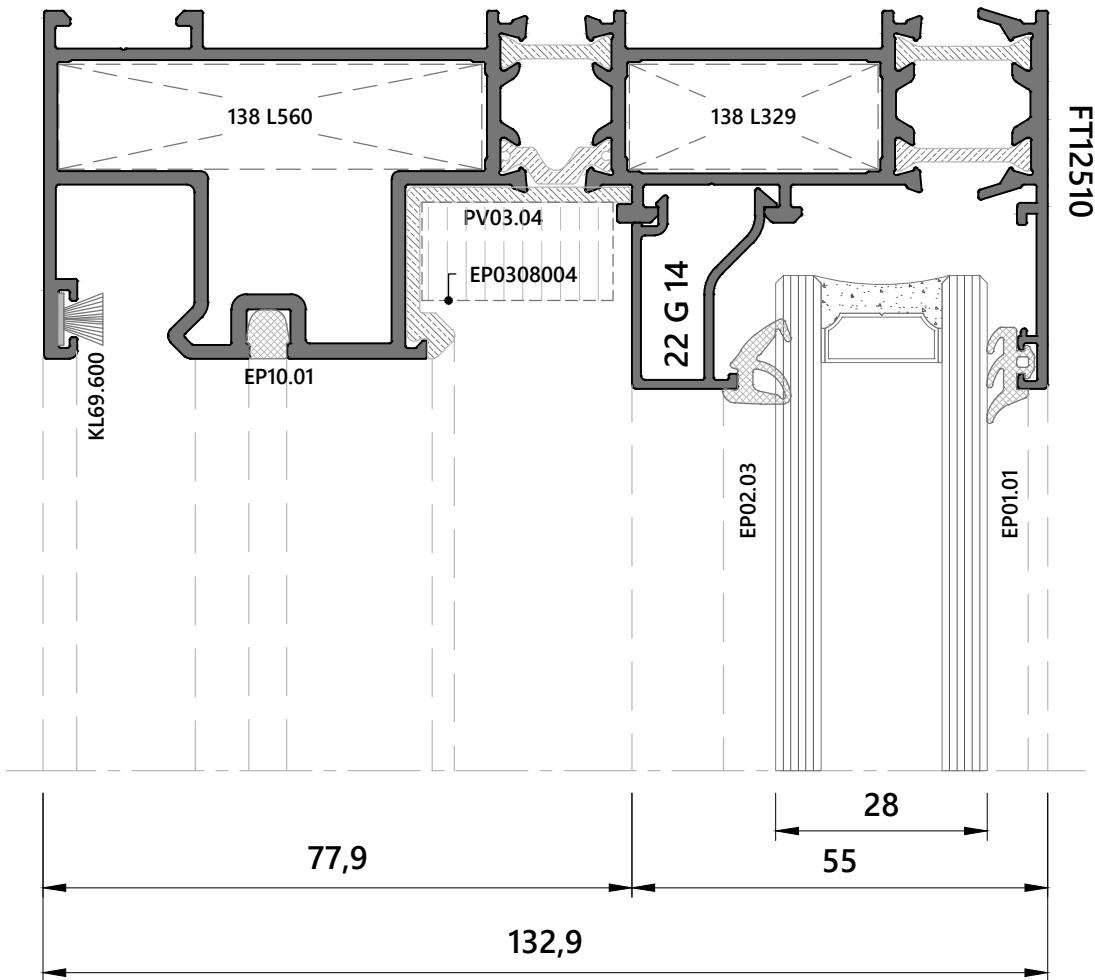

DETAY - 9
DETAIL - 9

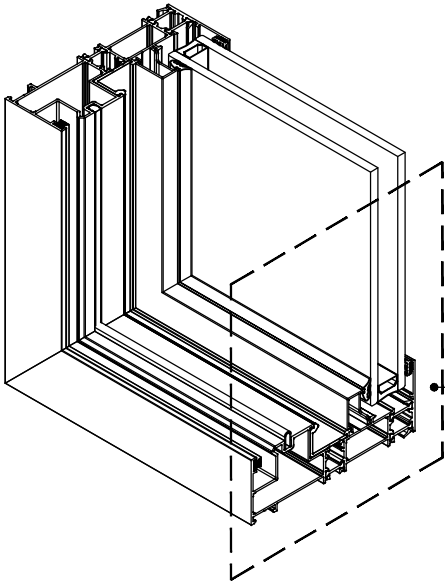

DETAY-9
DETAIL-9

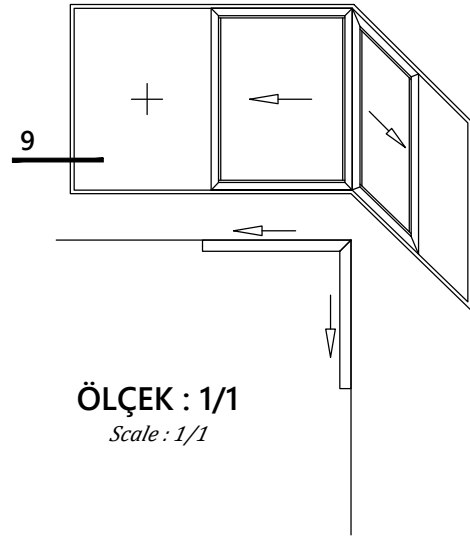

ÖLÇEK : 1/1
Scale : 1/1

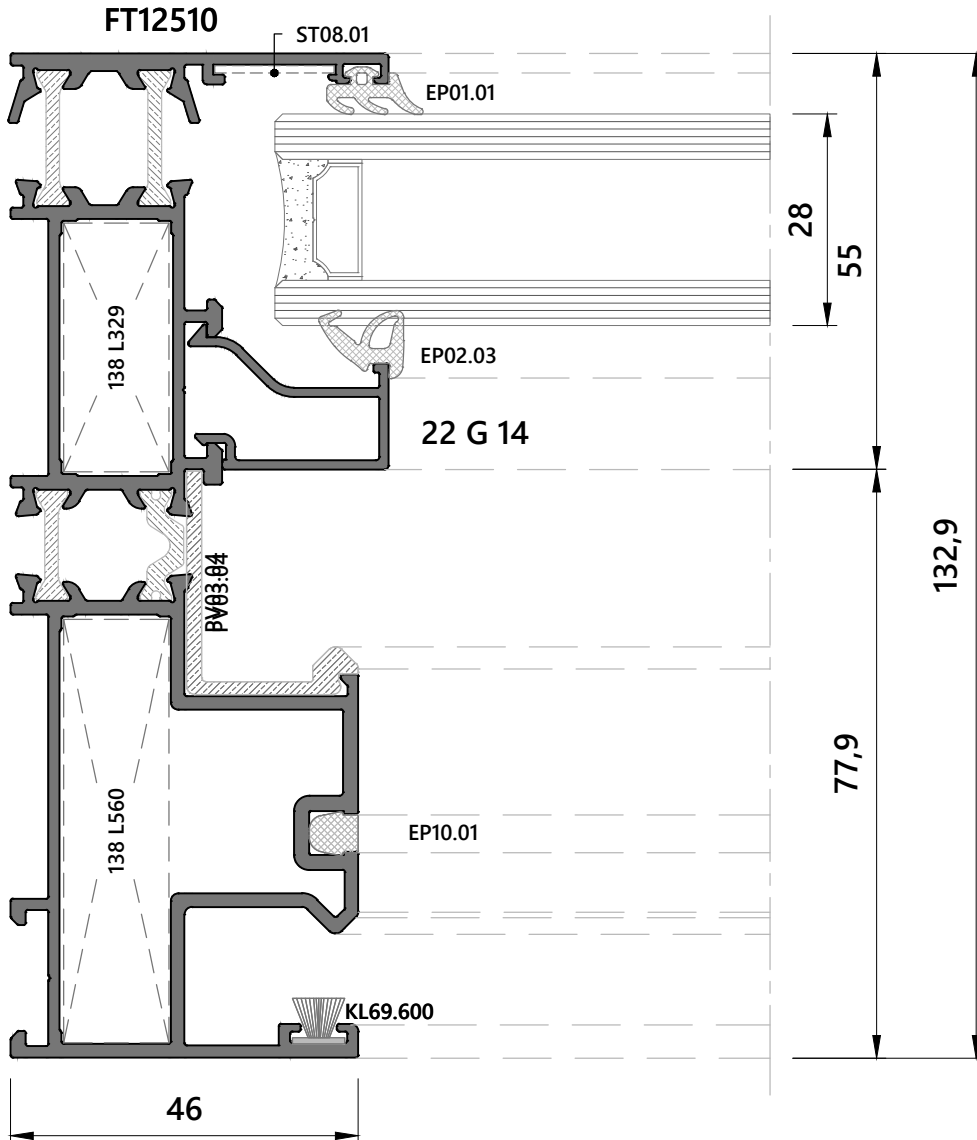

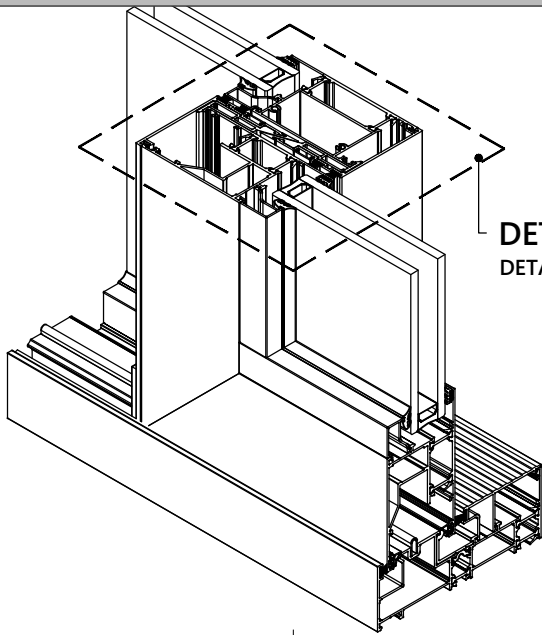

DETAY - 10
DETAIL - 10

DETAY - 10
DETAIL - 10

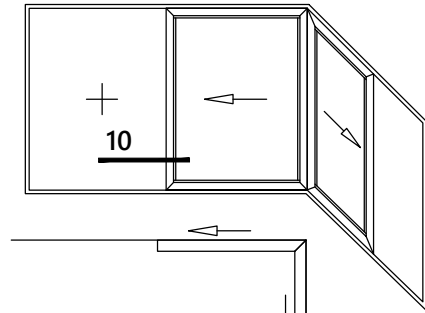

ÖLÇEK : 1/1
Scale : 1/1

102

MT12502

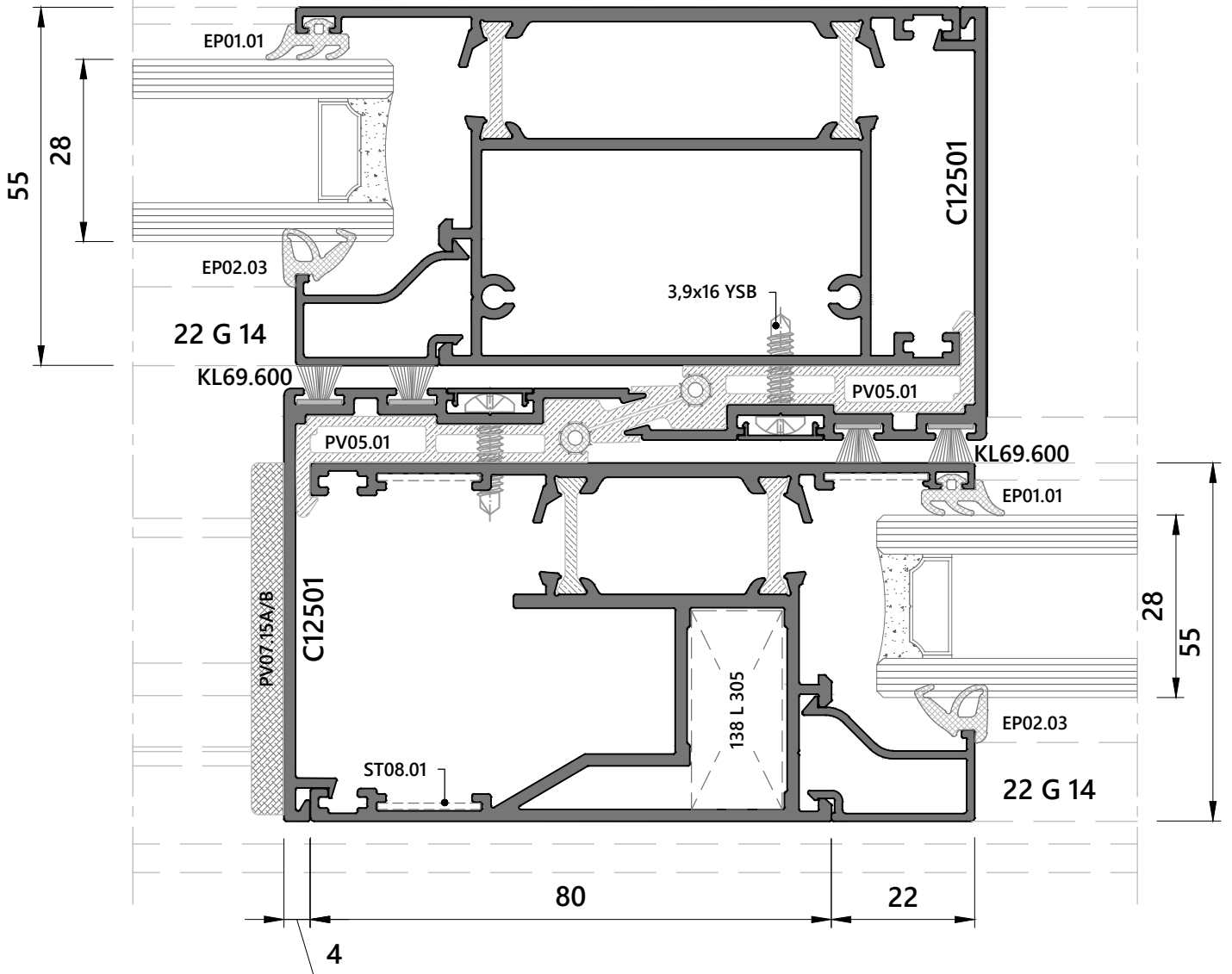

DETAY - 11
DETAIL - 11

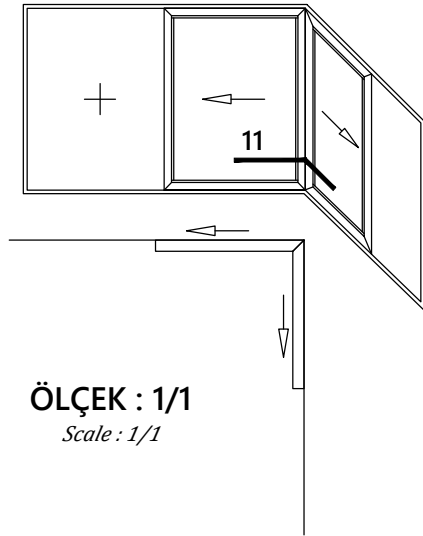
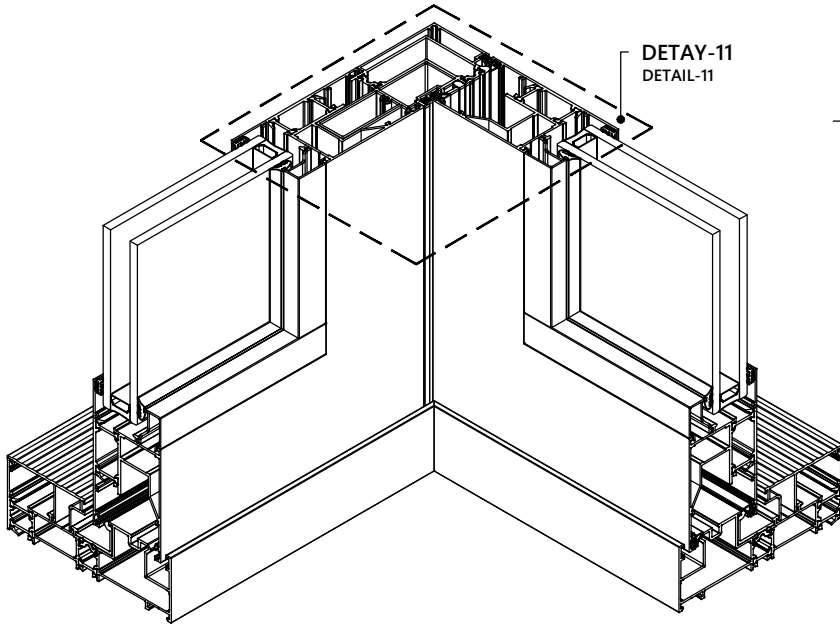

ÖLÇEK : 1/1
Scale : 1/1

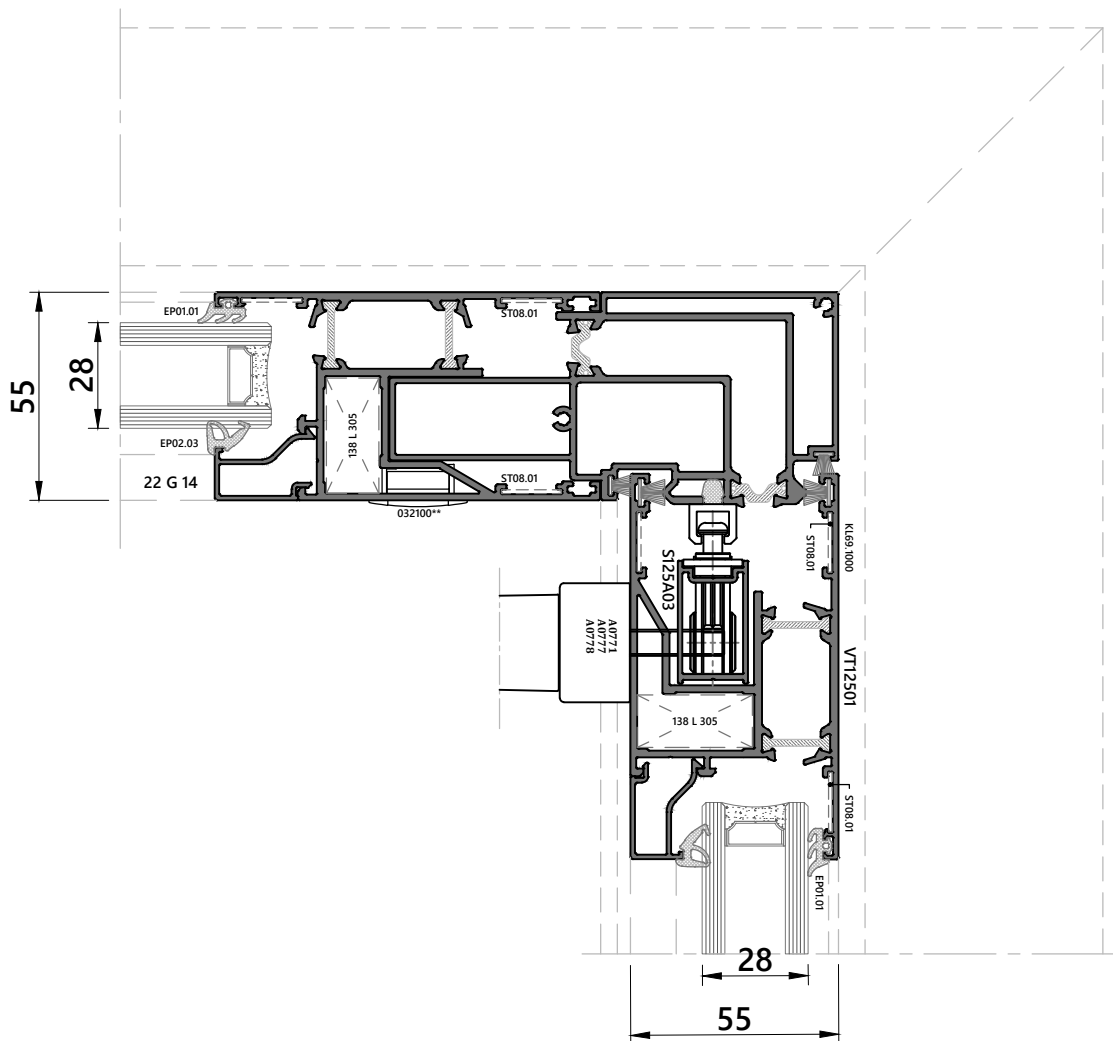

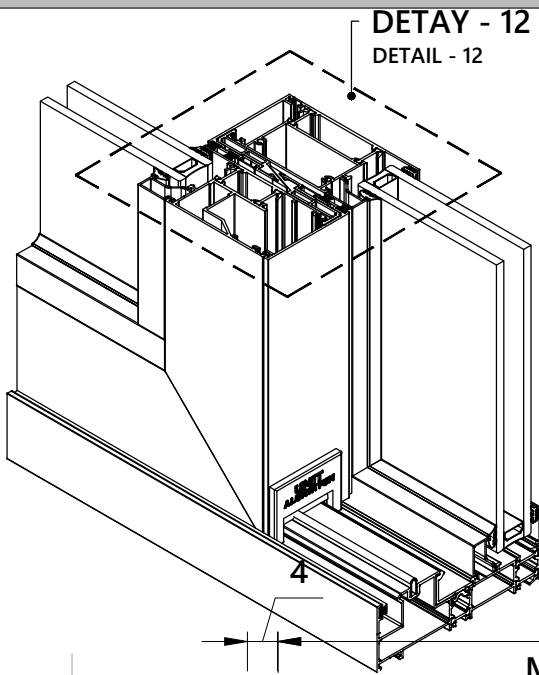

DETAIL - 12
DETAIL - 12

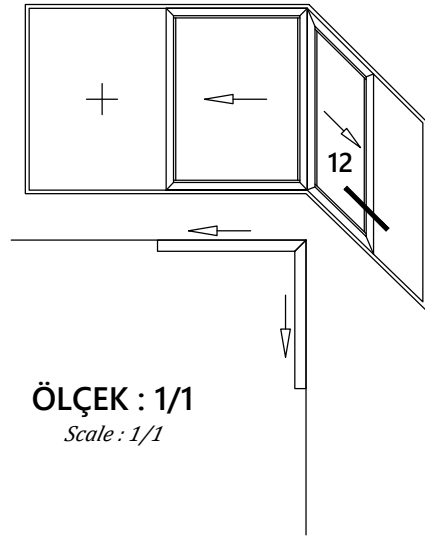

ÖLÇEK : 1/1
Scale : 1/1

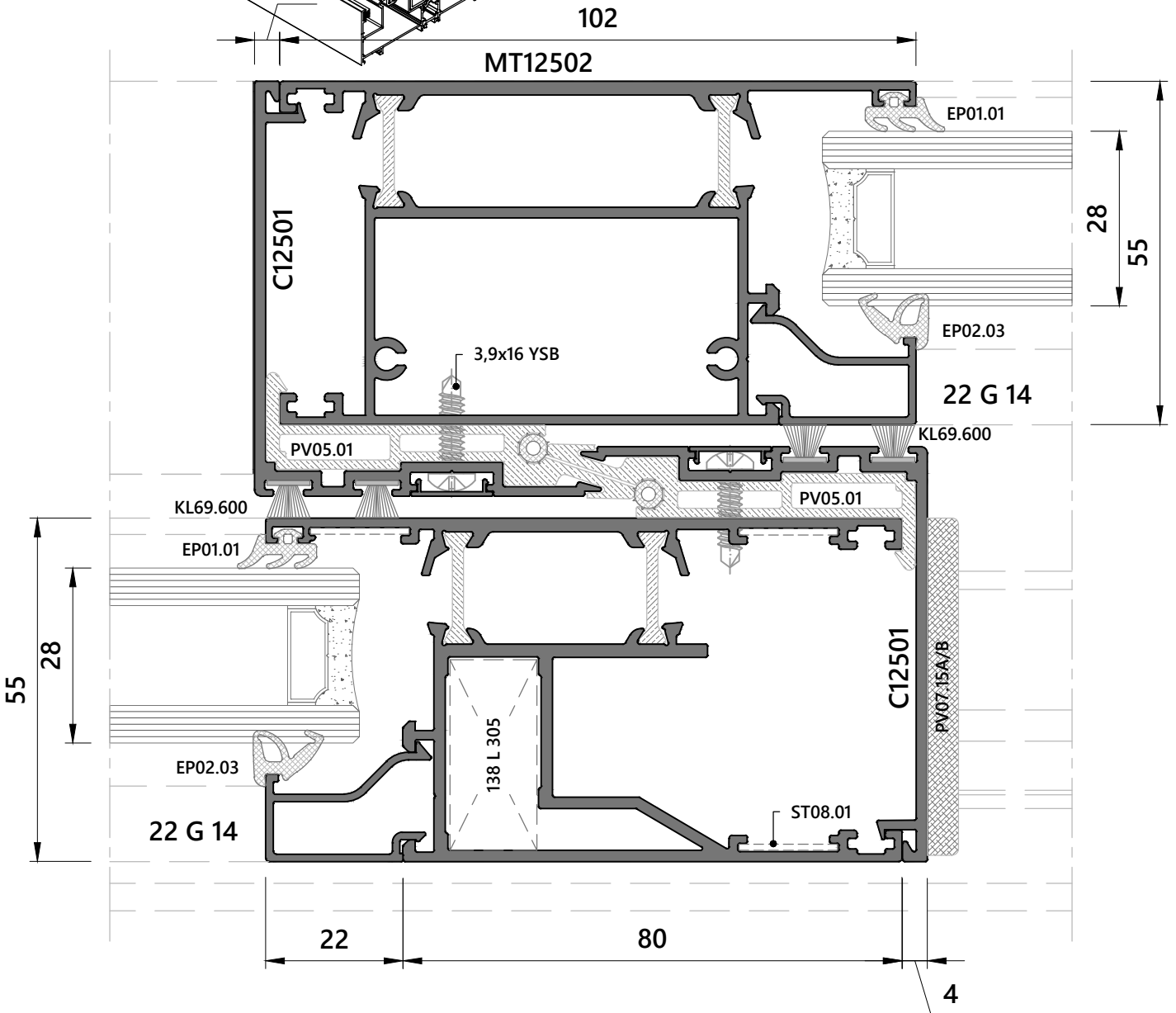

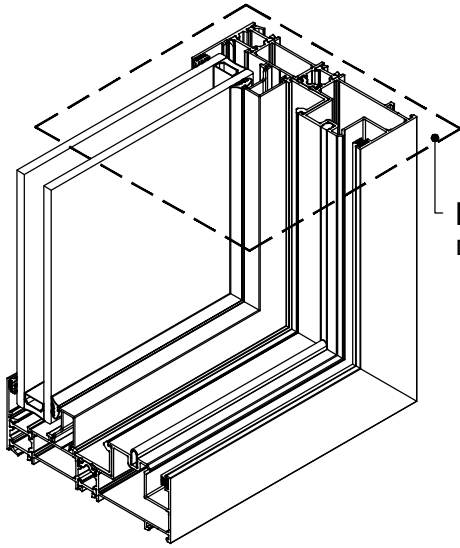

DETAY - 13
DETAIL - 13

DETAY - 13
DETAIL - 13

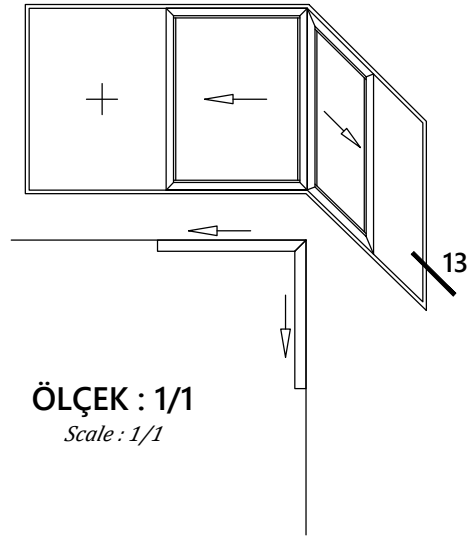

ÖLÇEK : 1/1
Scale : 1/1

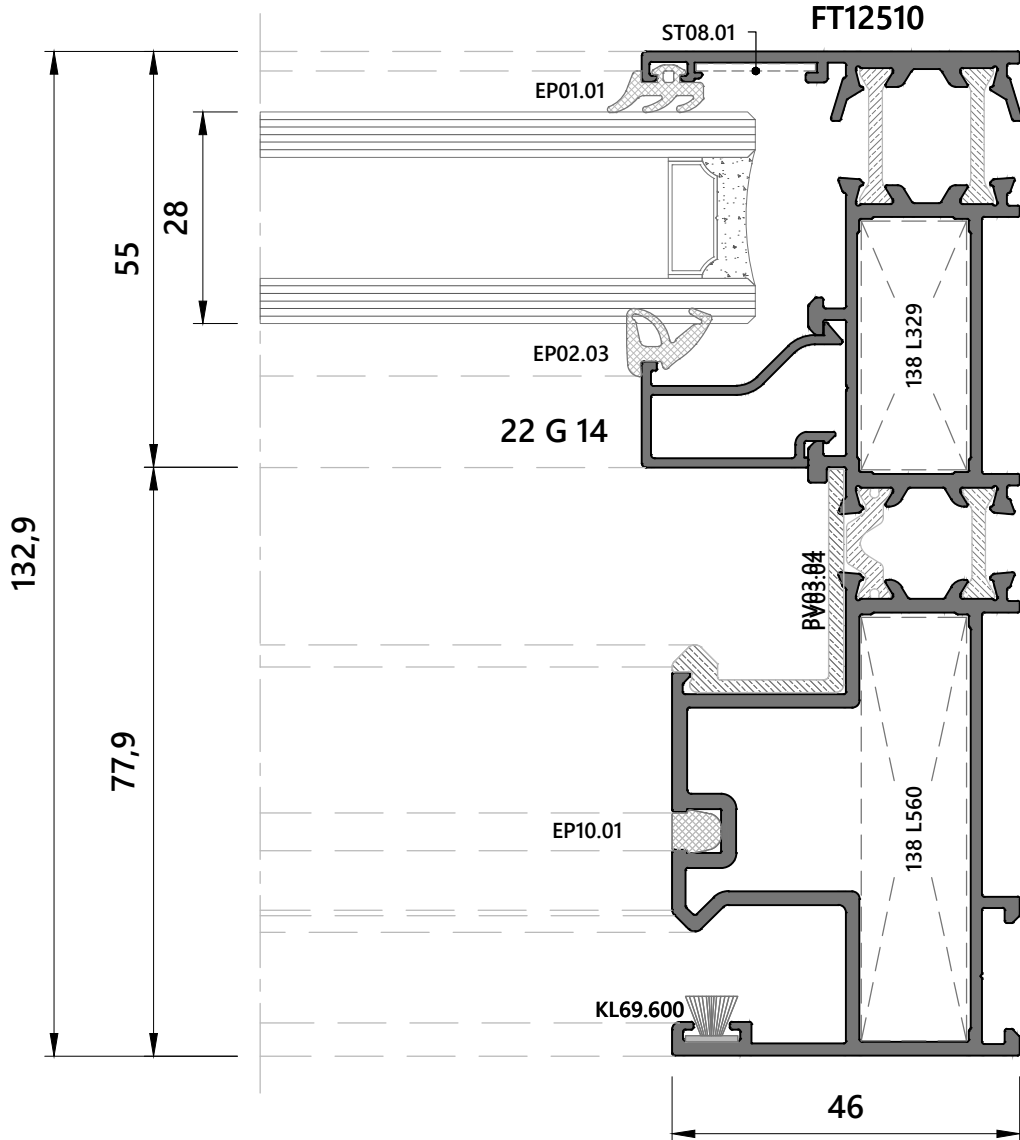

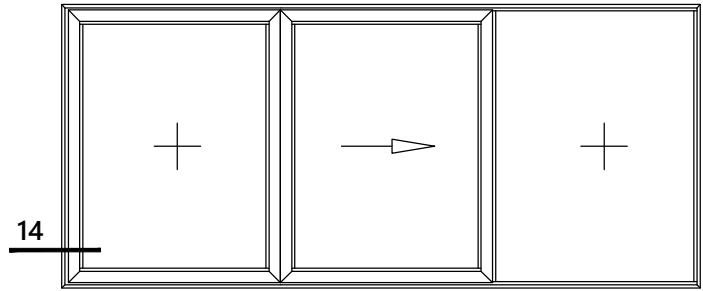
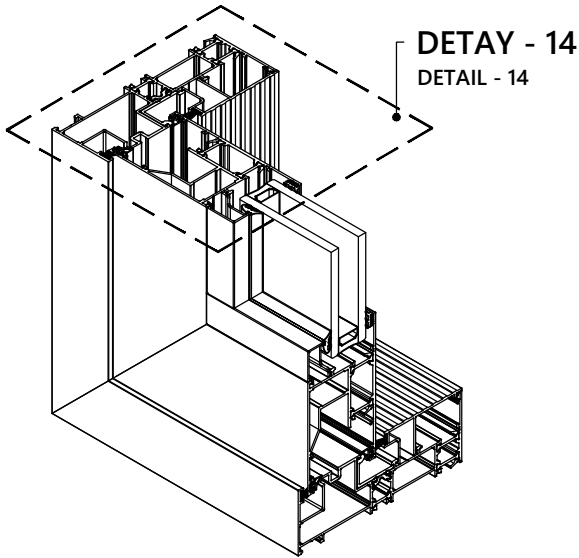

ÖLÇEK : 1/1
Scale : 1/1

DETAIL - 14
DETAIL - 14

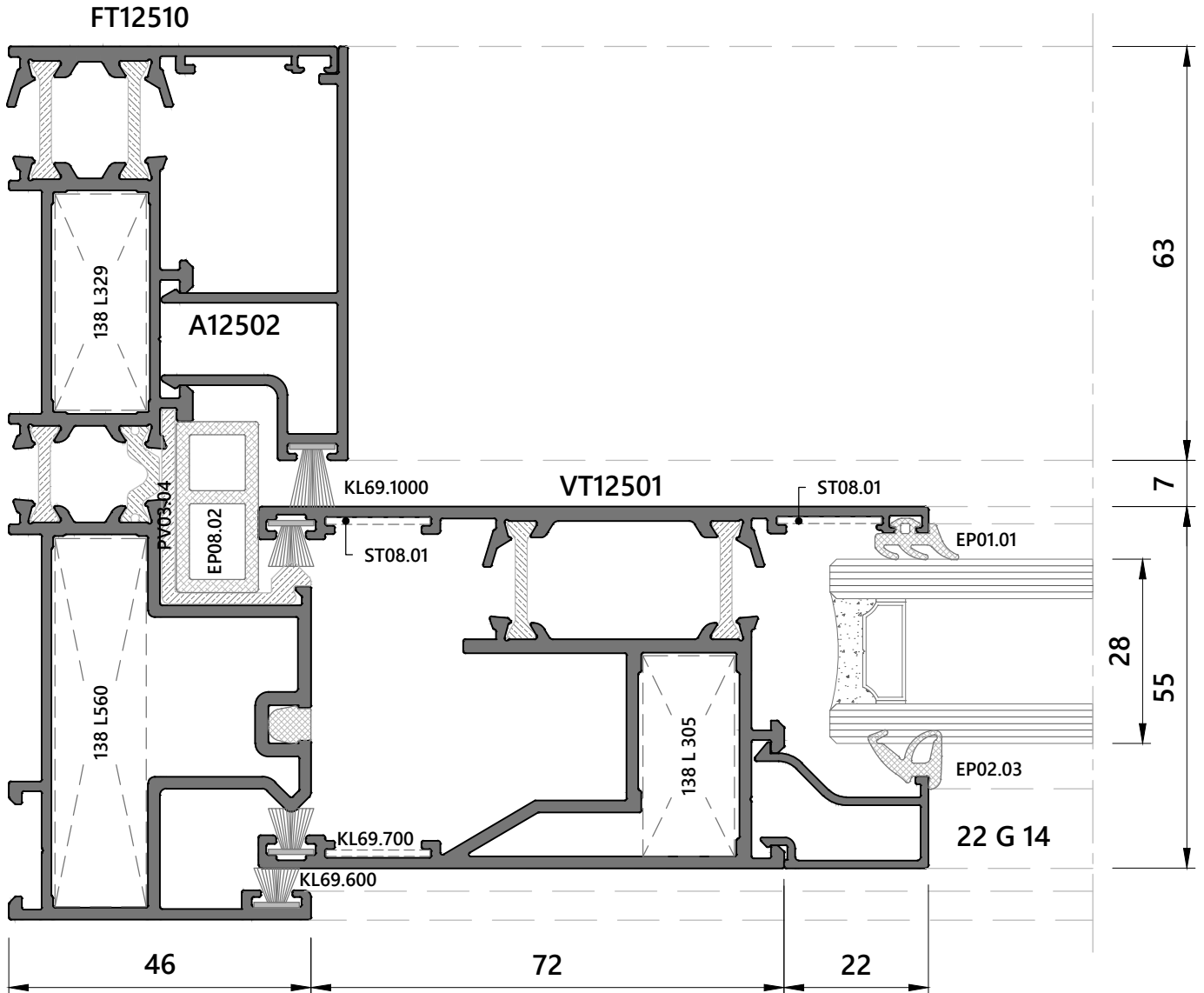

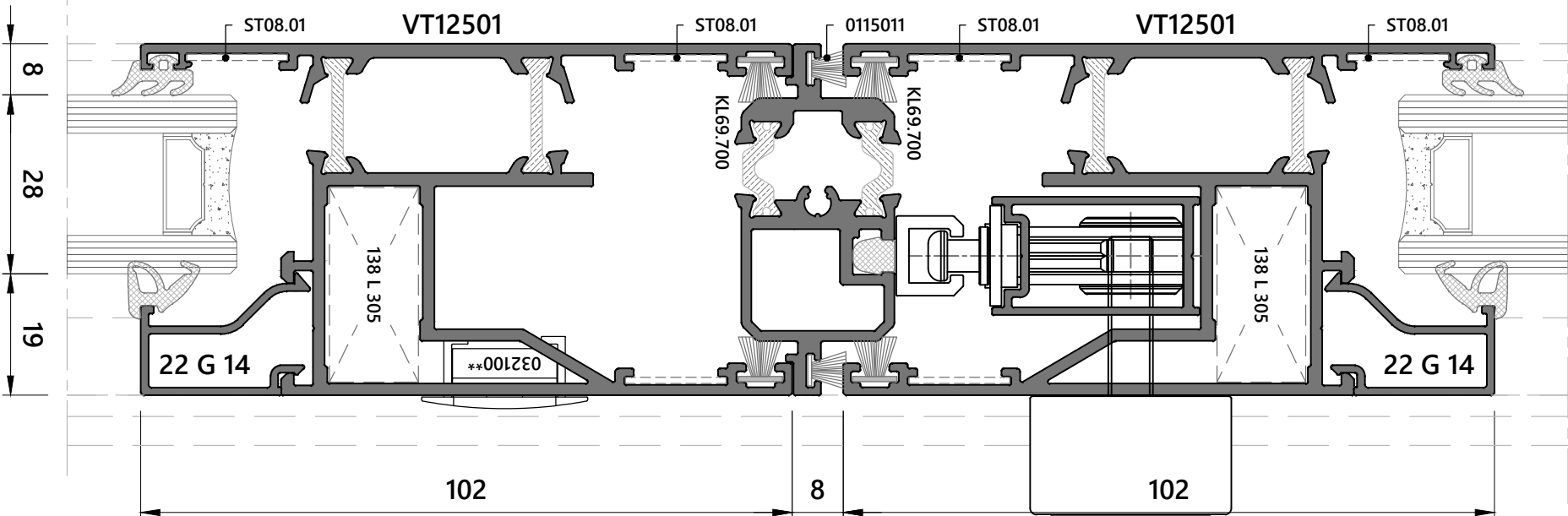
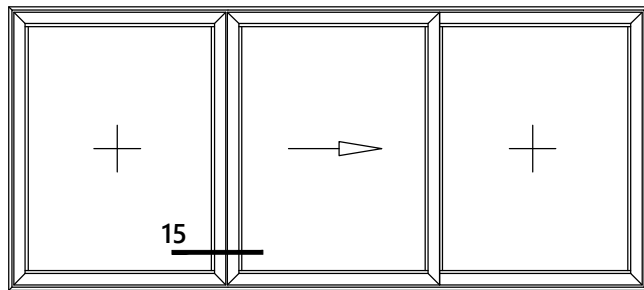

DETAY - 15
DETAIL - 15

ÖLÇEK : 1/1
Scale : 1/1

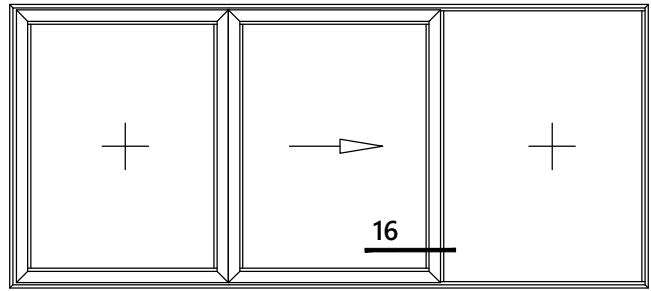
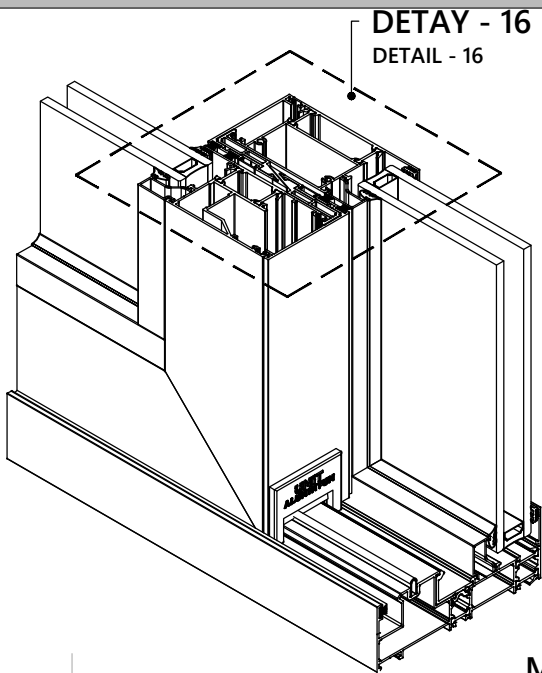

ÖLÇEK : 1/1
Scale : 1/1

DETAIL - 16
DETAIL - 16

MT12502

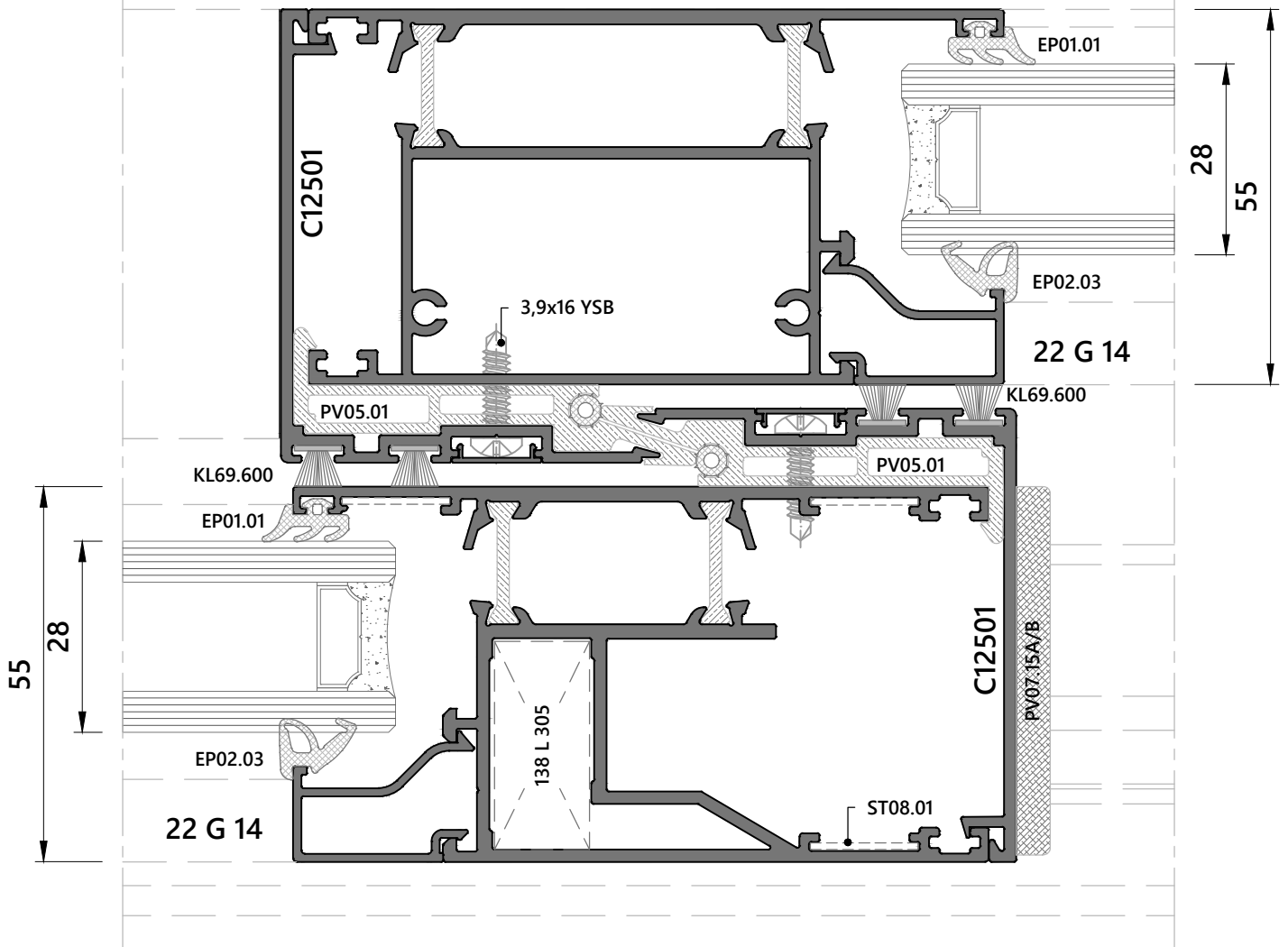

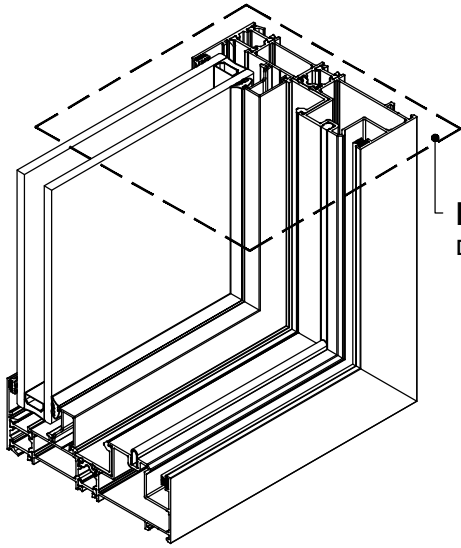

DETAY - 17
DETAIL - 17

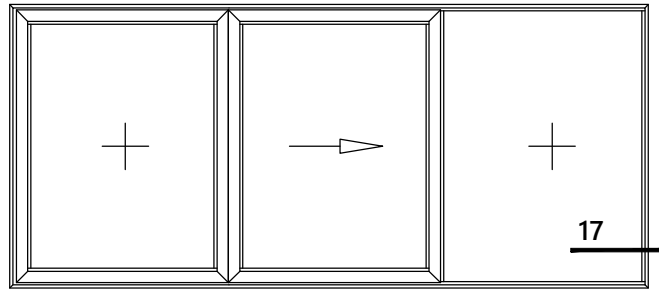

17

ÖLÇEK : 1/1
Scale : 1/1

DETAY - 17
DETAIL - 17

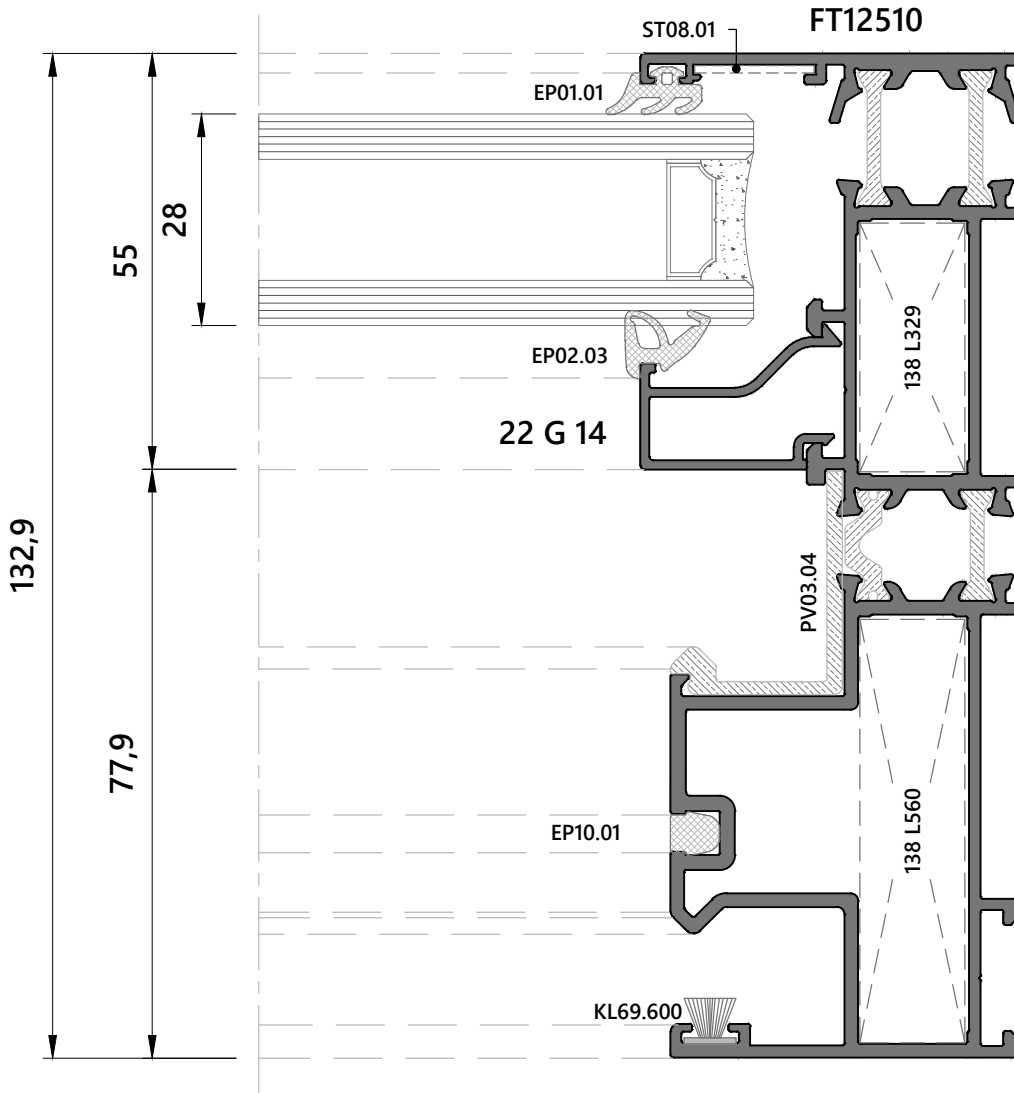

İKİ RAYLI KASA UYGULAMA DETAYLARI
APPLICATION DETAILS for DOUBLE RAIL FRAME

KALDIRSÜR AÇILIM TİPLERİ

LIFT&SLIDE TYPES OF OPENING

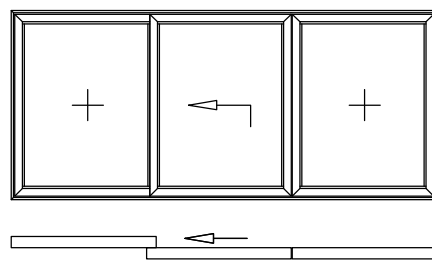
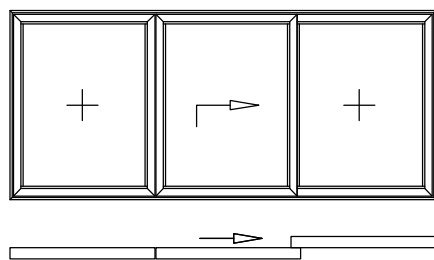
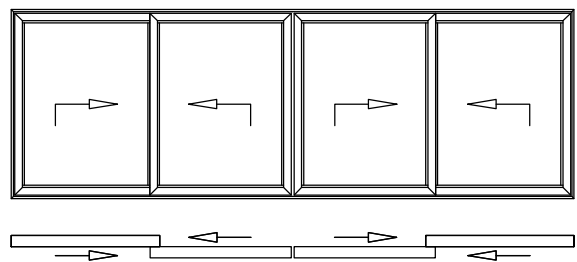
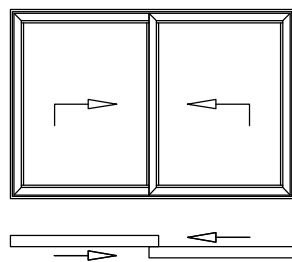
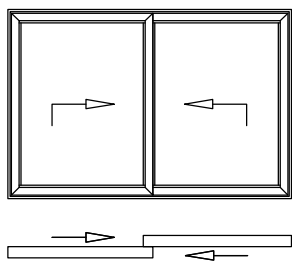
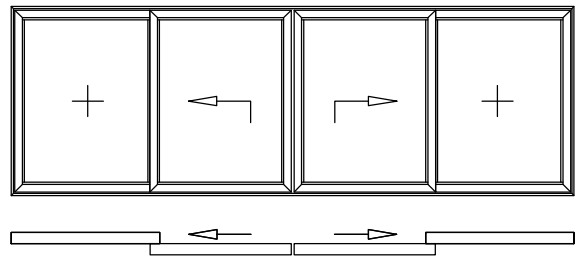
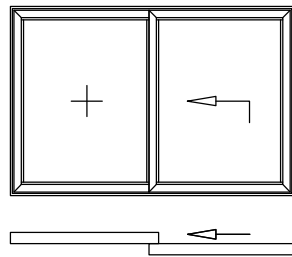
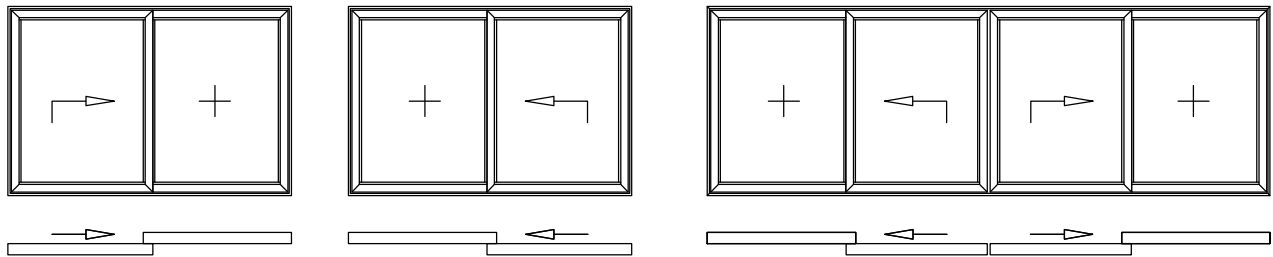

DETAY - 1
DETAIL - 1

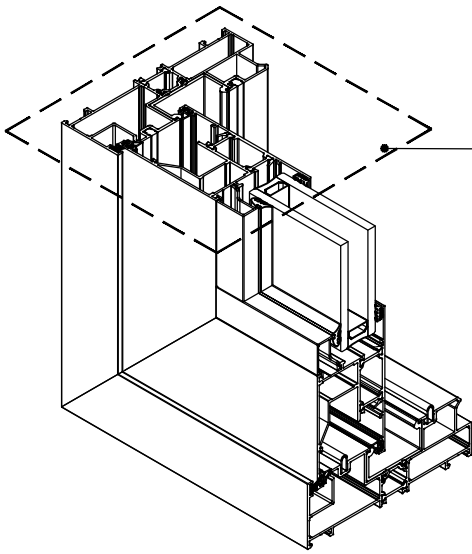

DETAY - 1
DETAIL - 1

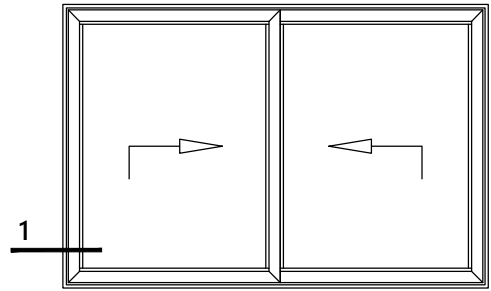

ÖLÇEK : 1/1
Scale : 1/1

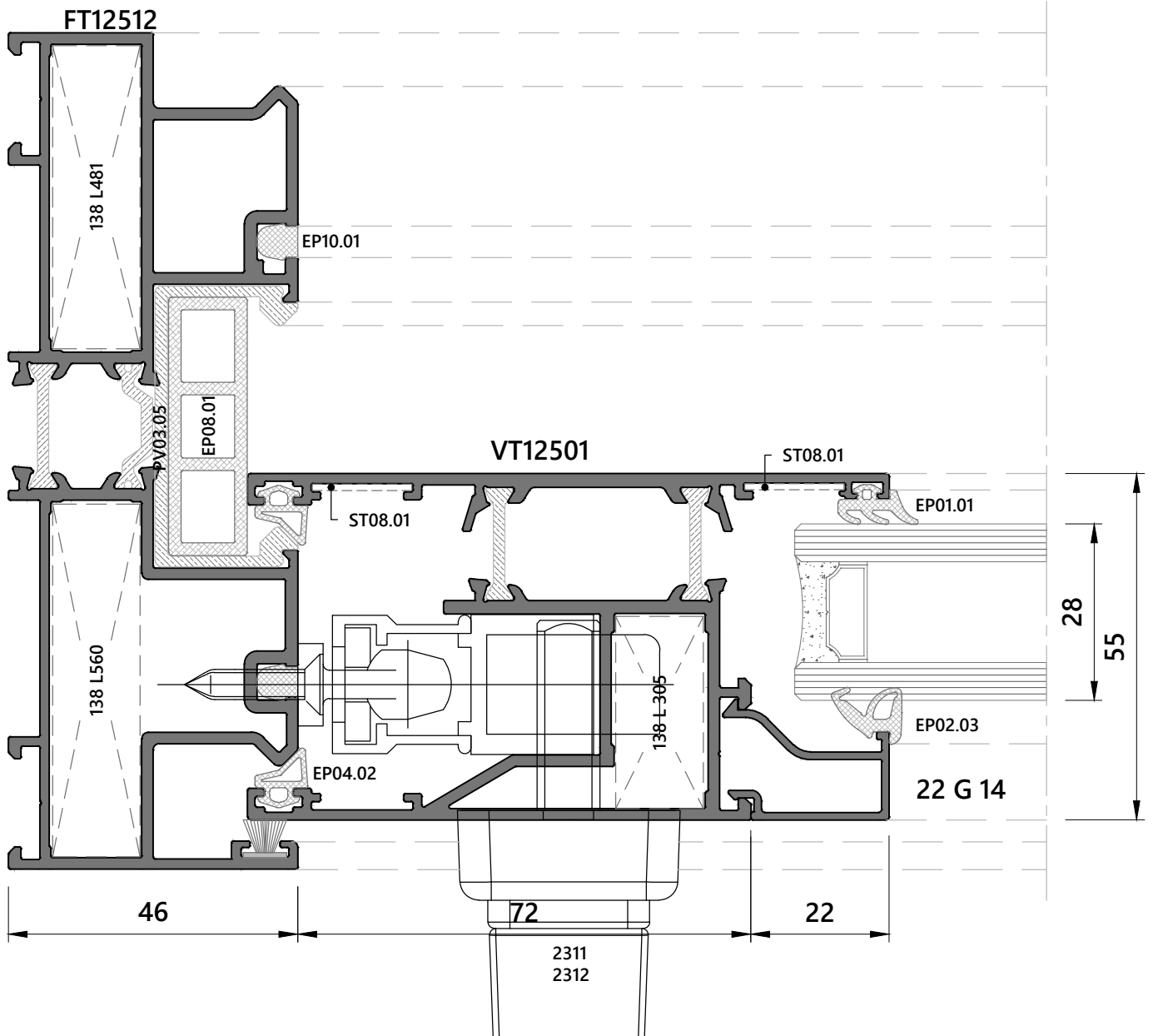

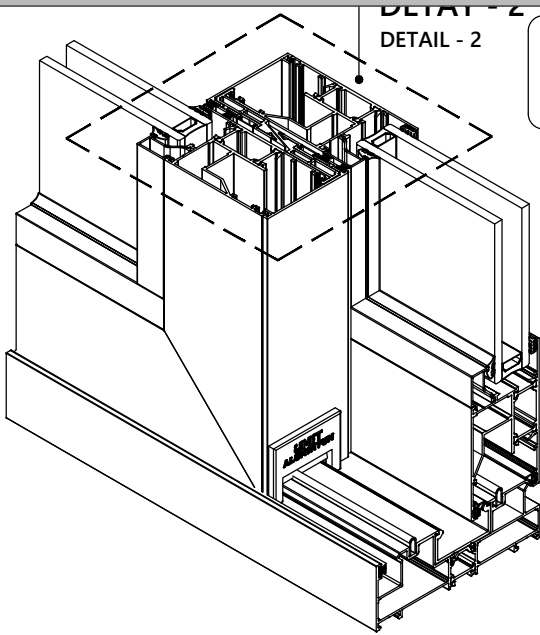

DETAIL - 2
DETAIL - 2

DETAIL - 2
DETAIL - 2

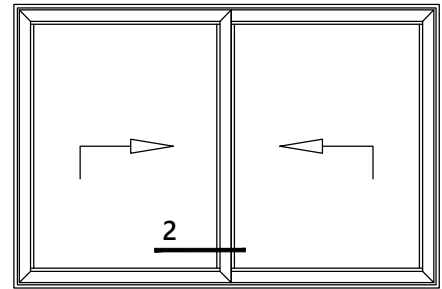

ÖLÇEK : 1/1
Scale : 1/1

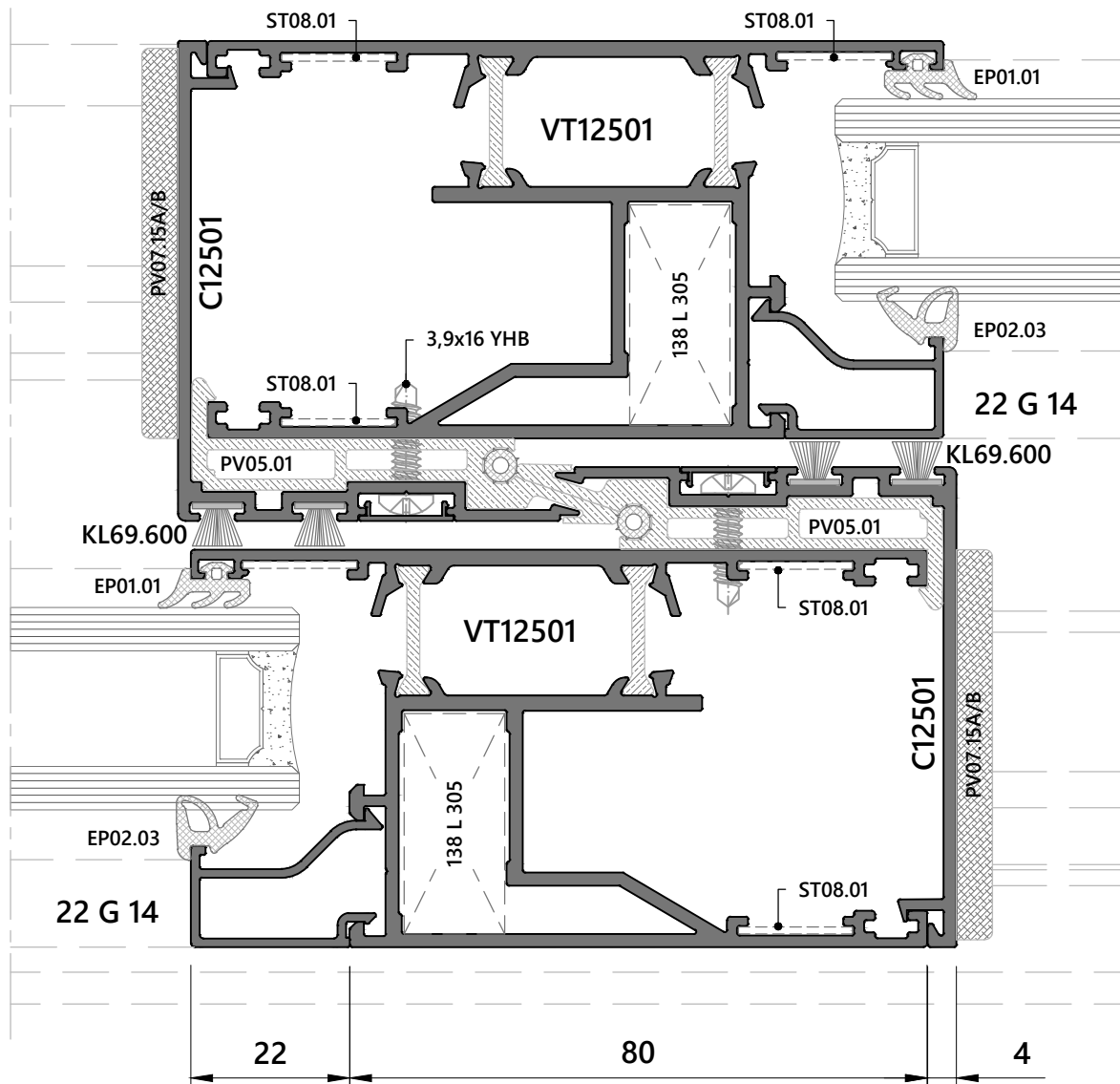

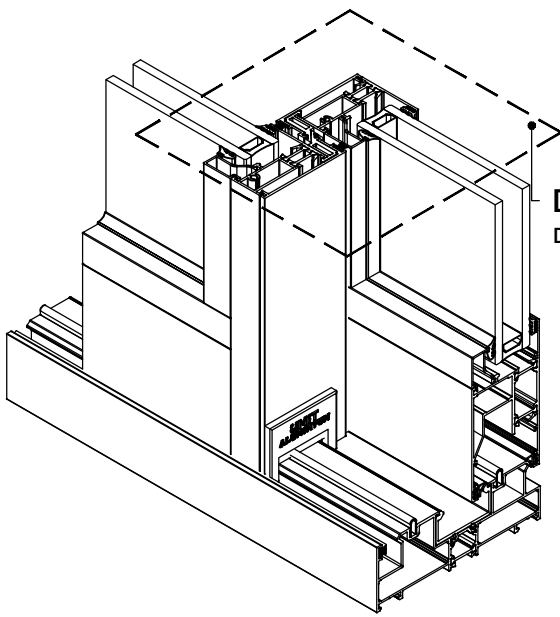

DETAY - 2a
DETAIL - 2a

DETAY - 2a
DETAIL - 2a

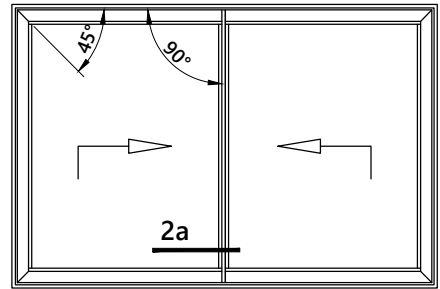

ÖLÇEK : 1/1
Scale : 1/1

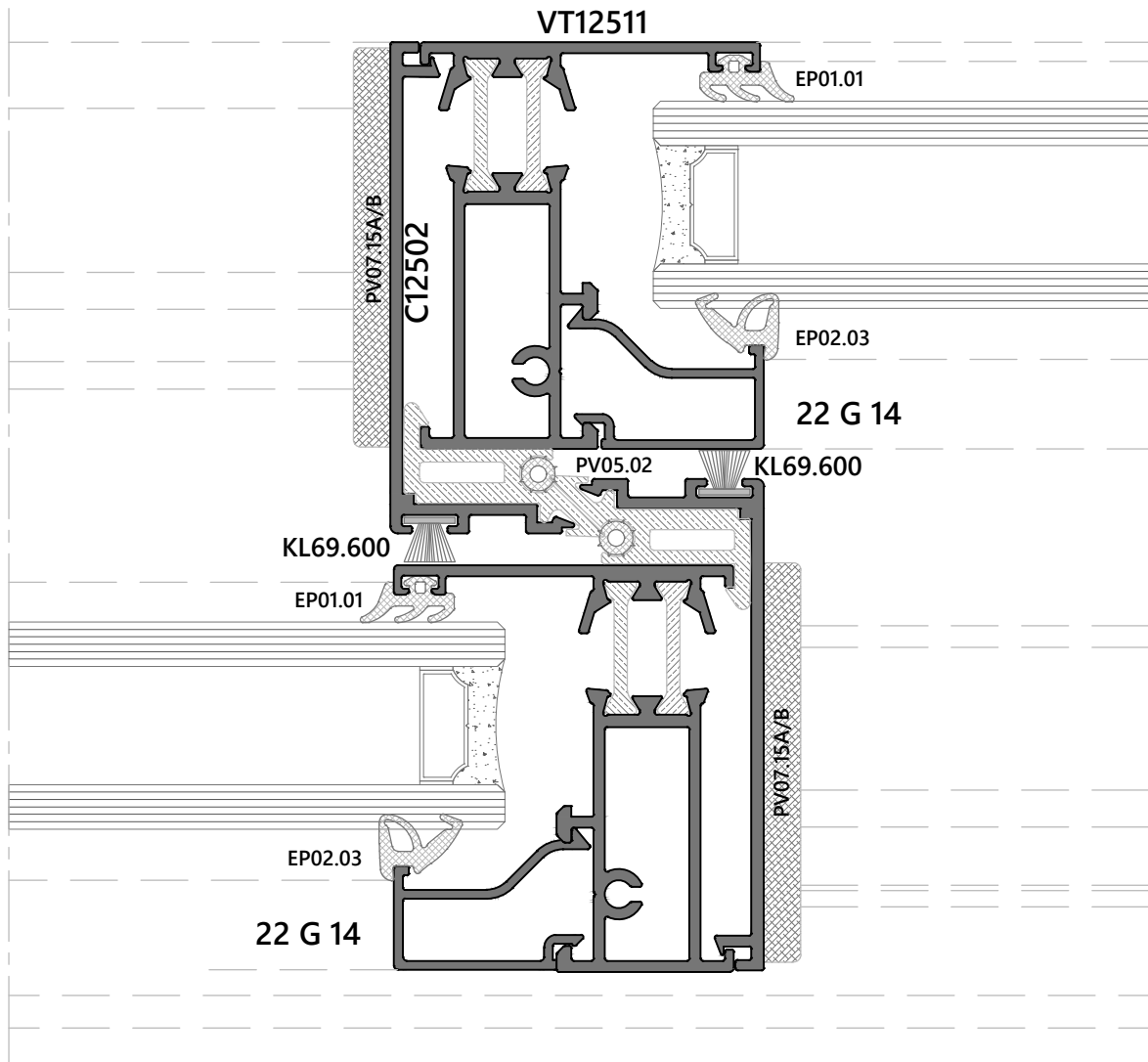

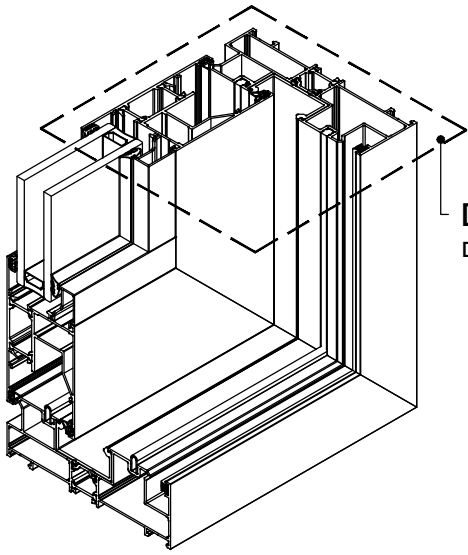

DETAY - 3
DETAIL - 3

DETAY - 3
DETAIL - 3

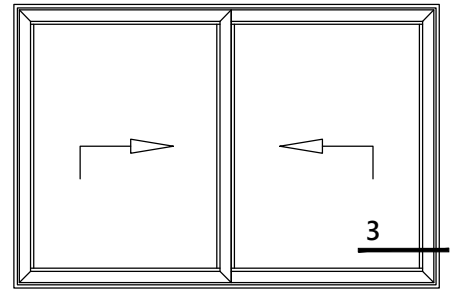

ÖLÇEK : 1/1
Scale : 1/1

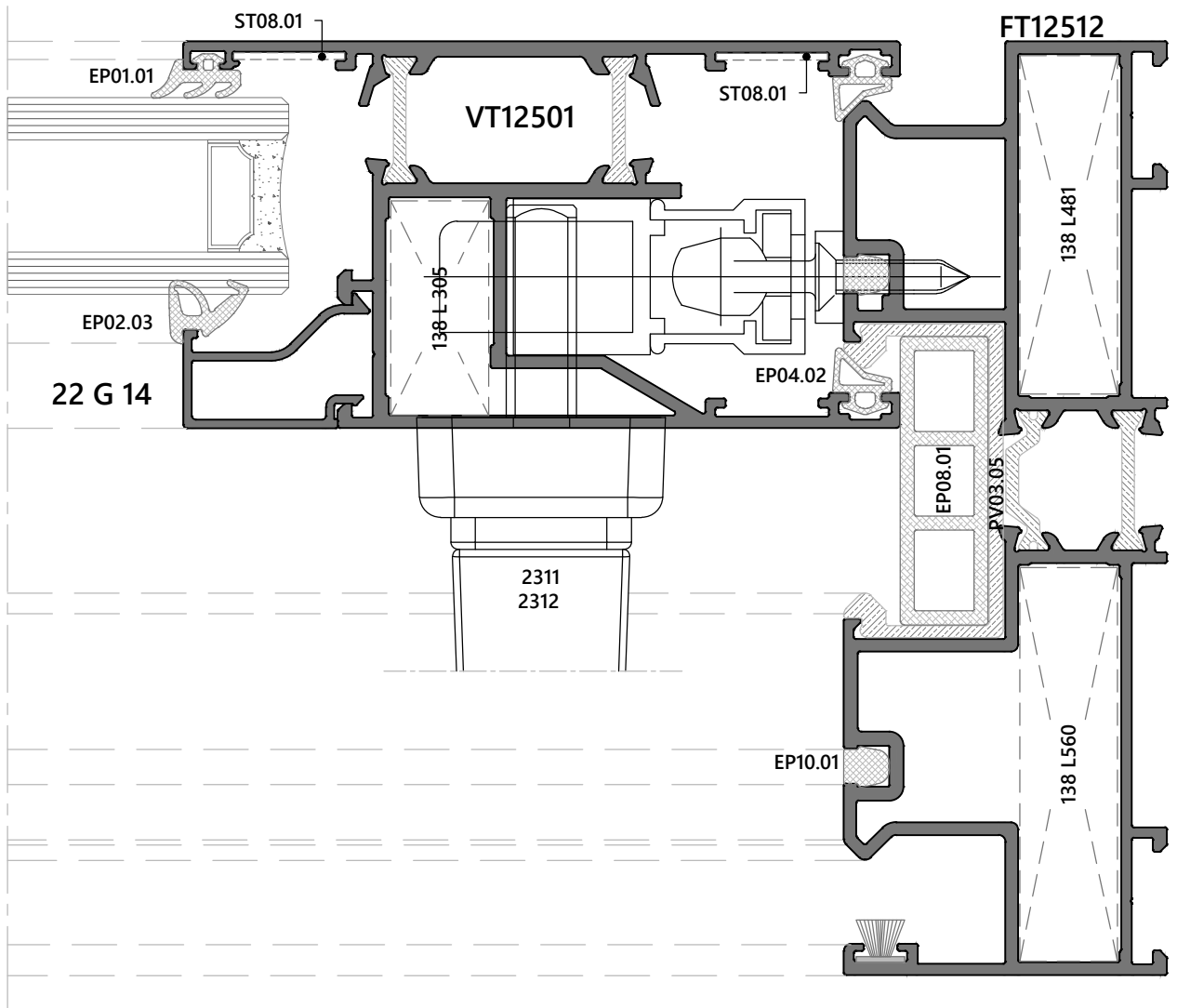

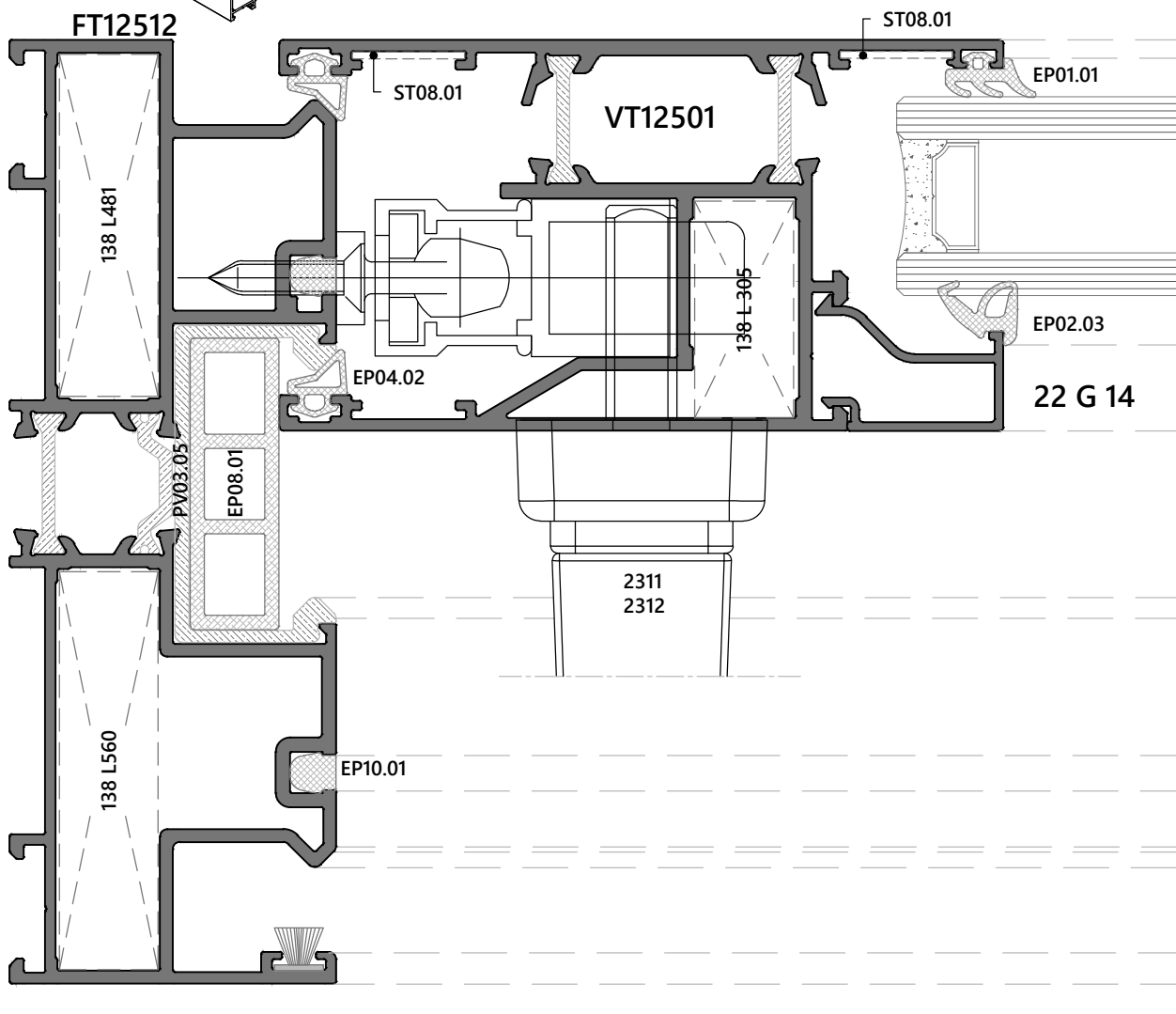
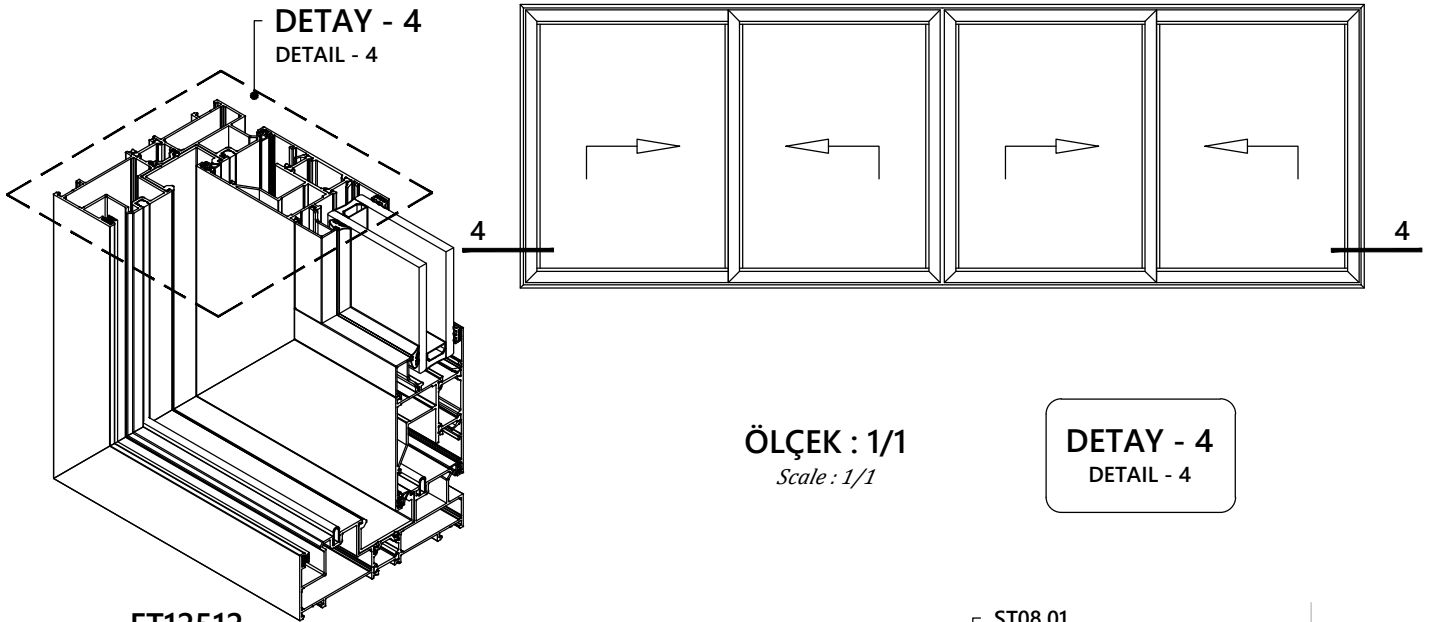

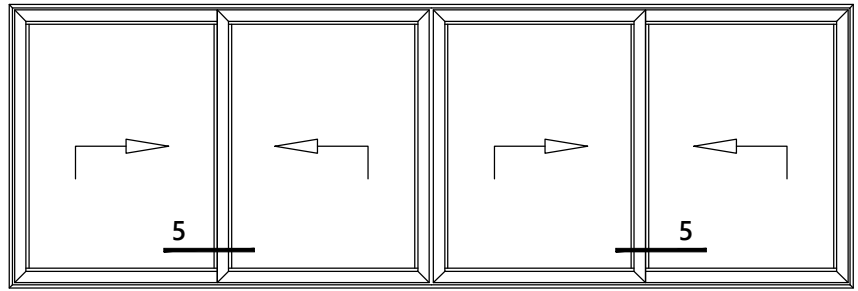
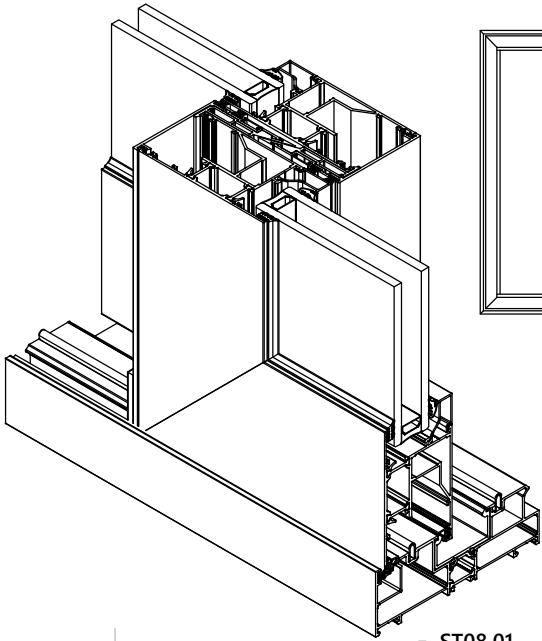

ÖLÇEK : 1/1
Scale : 1/1

DETAY - 5
DETAIL - 5

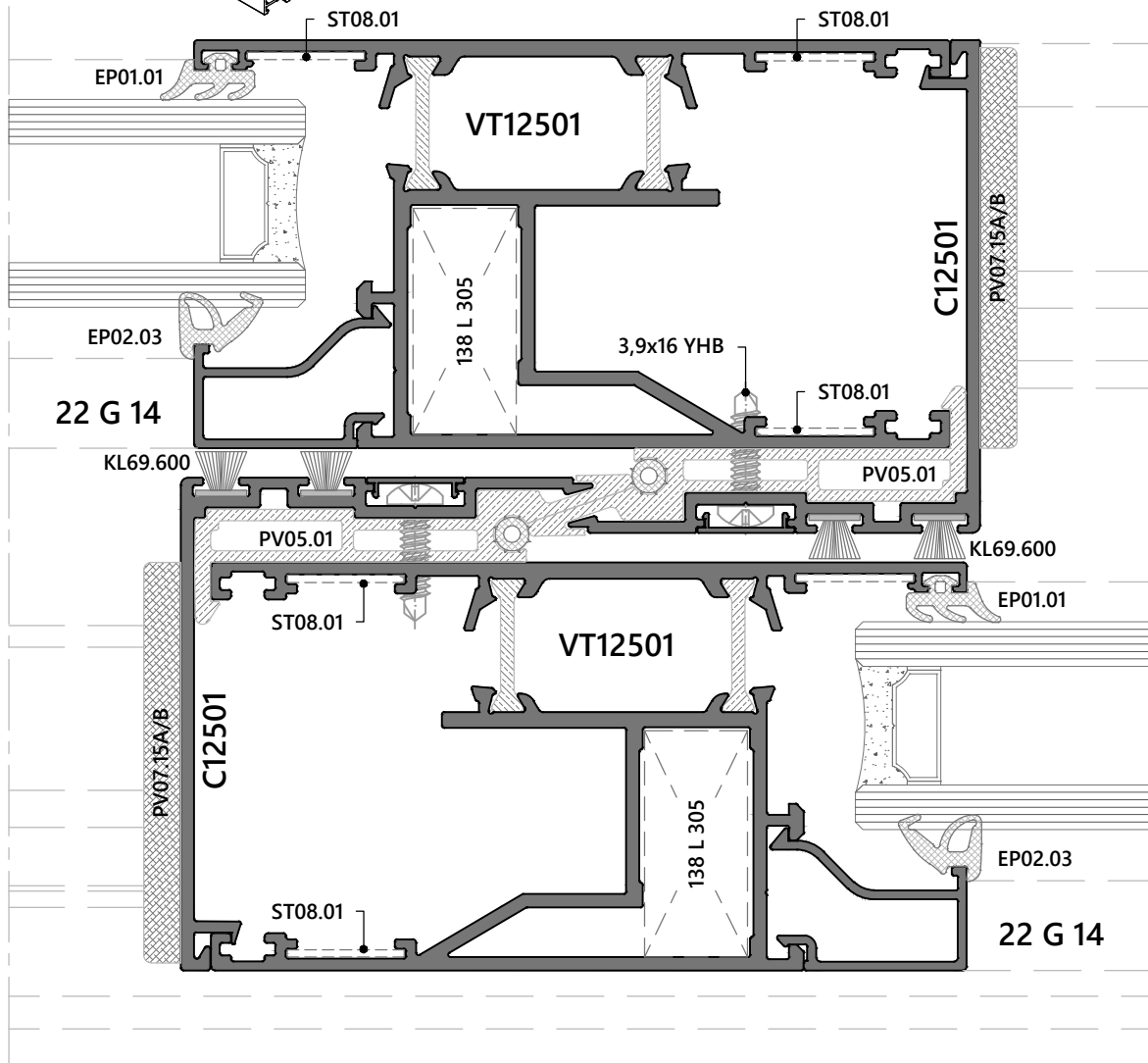

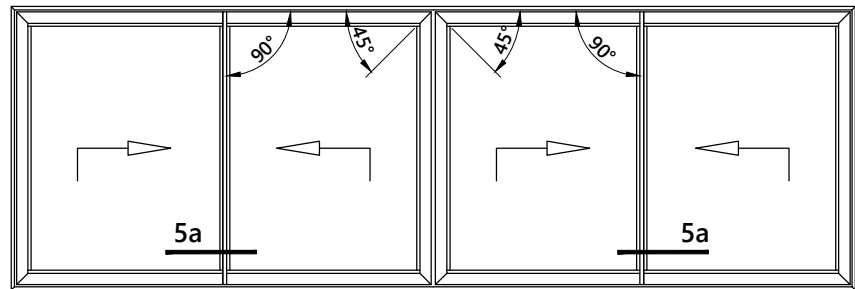

ÖLÇEK : 1/1
Scale : 1/1

DETAY - 5a
DETAIL - 5a

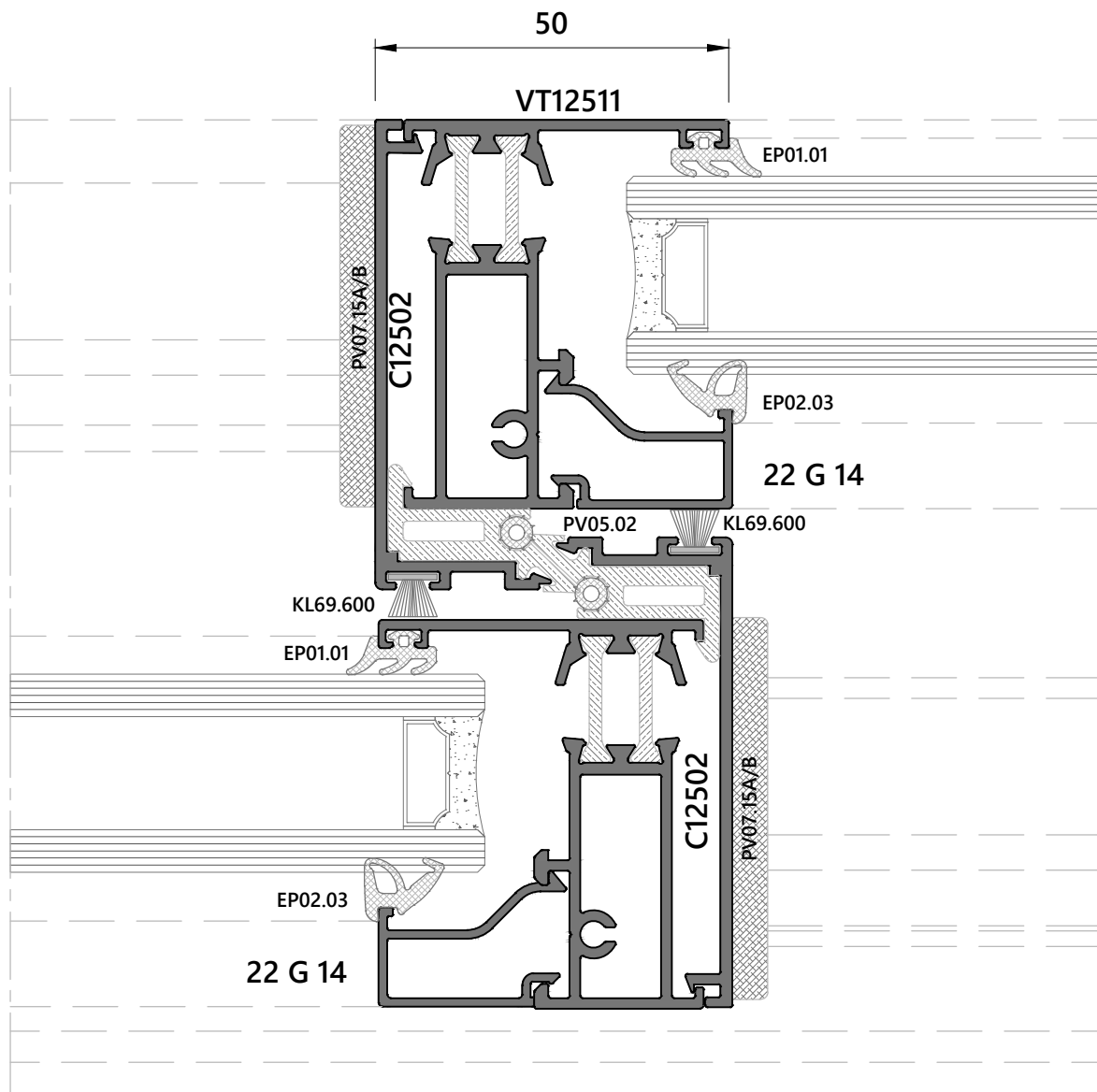

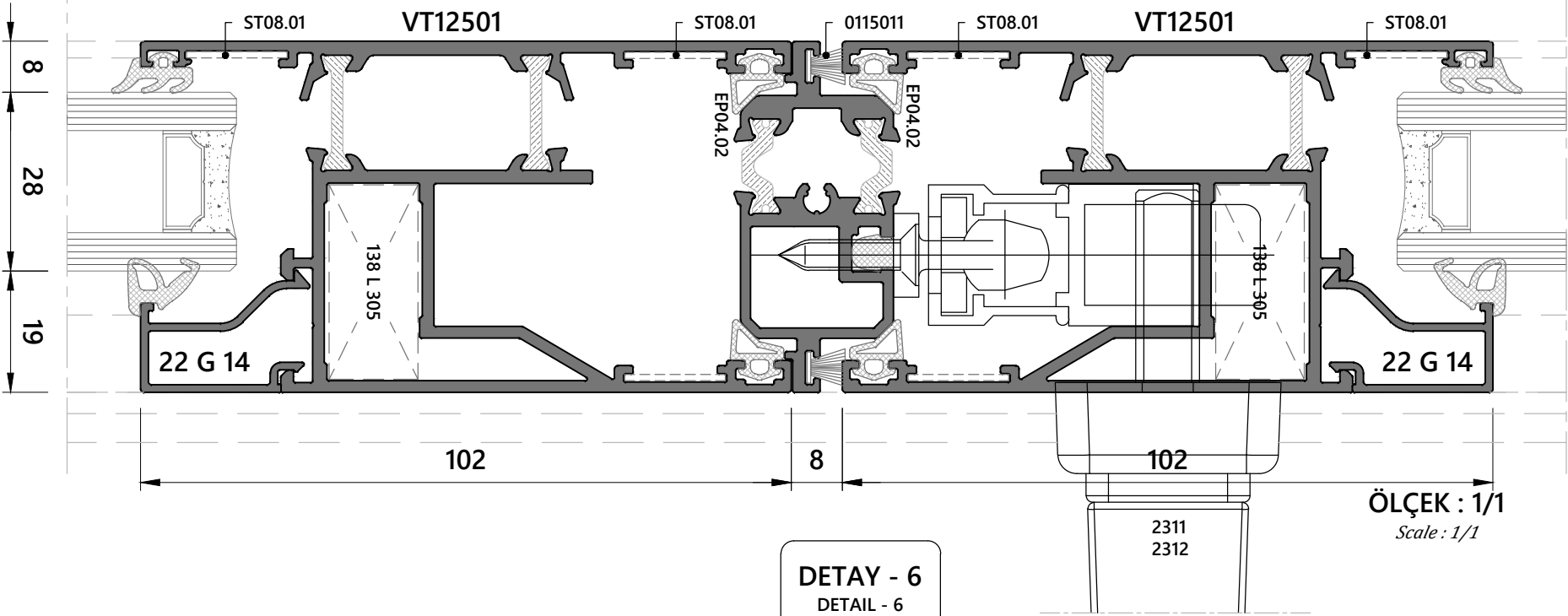
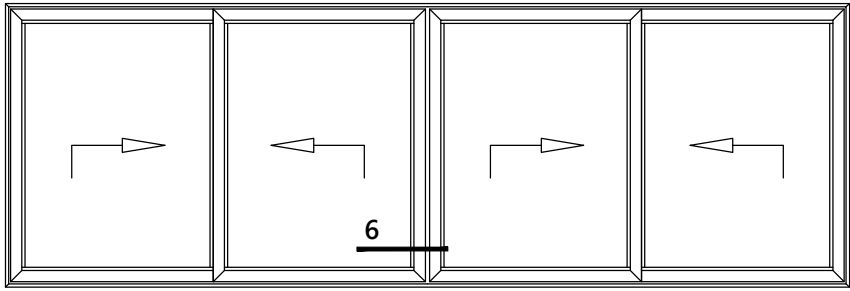

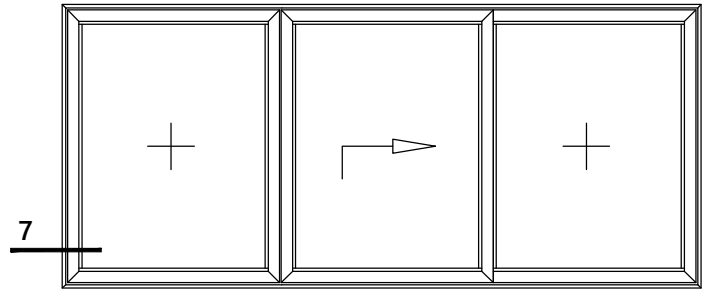
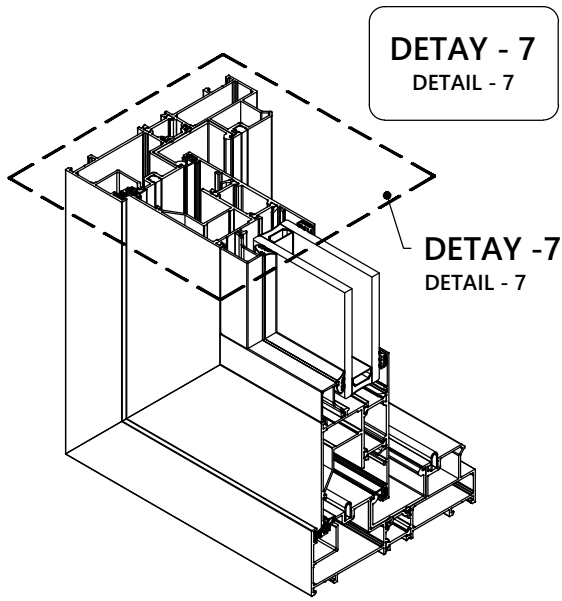

ÖLÇEK : 1/1
Scale : 1/1

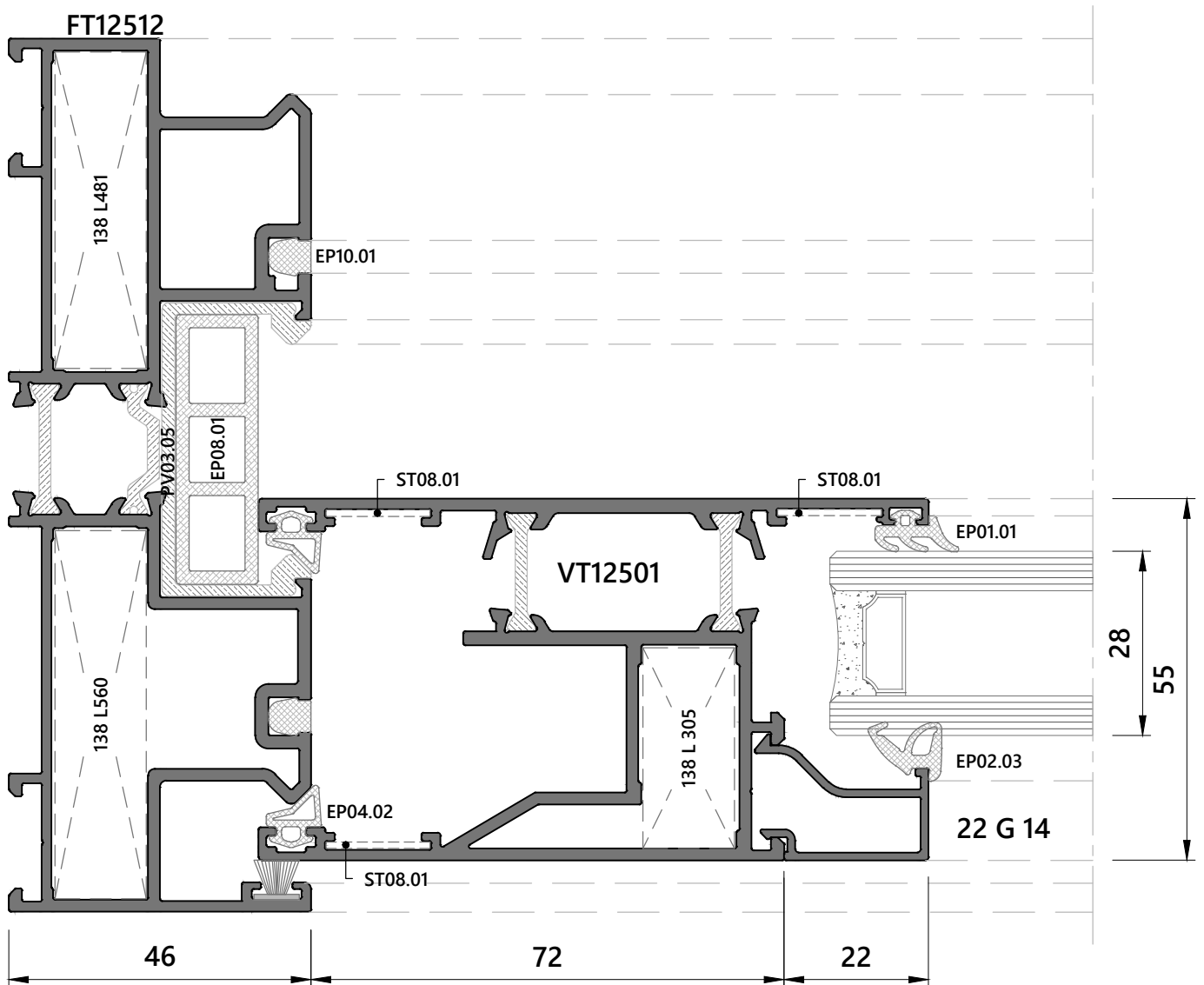

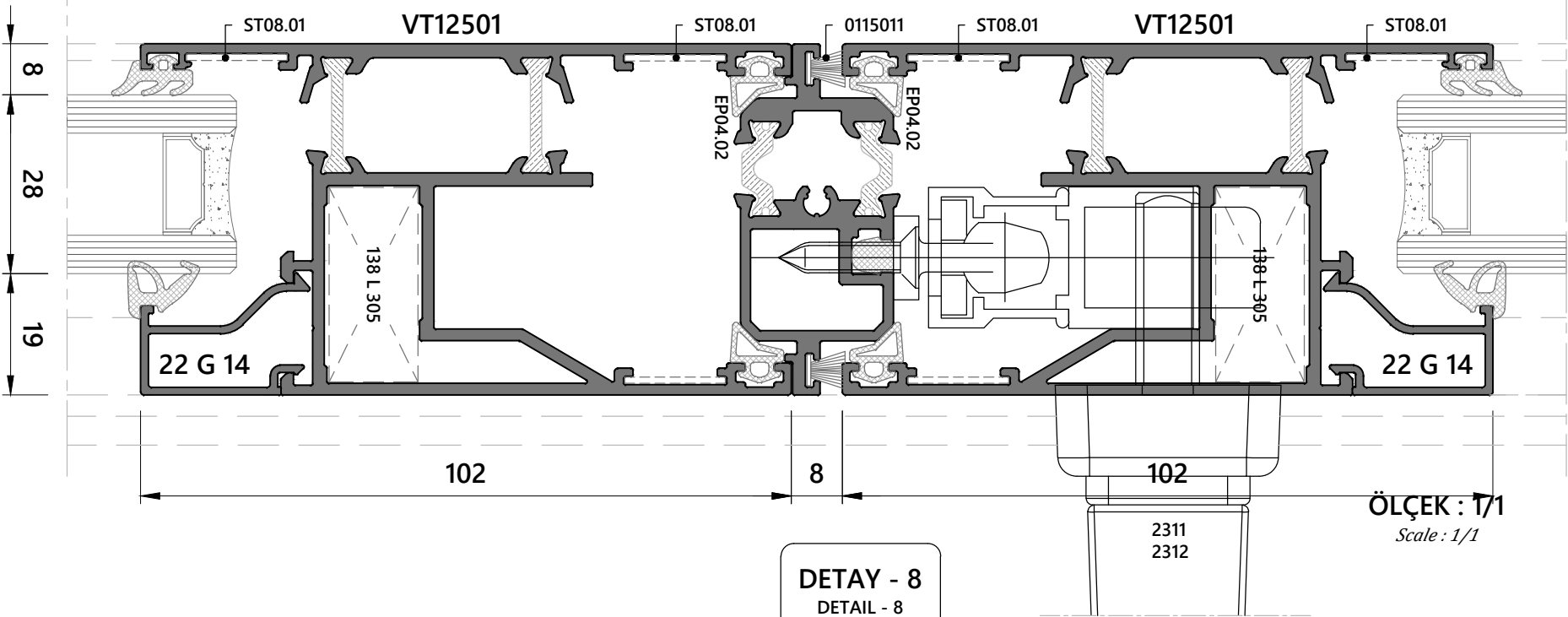
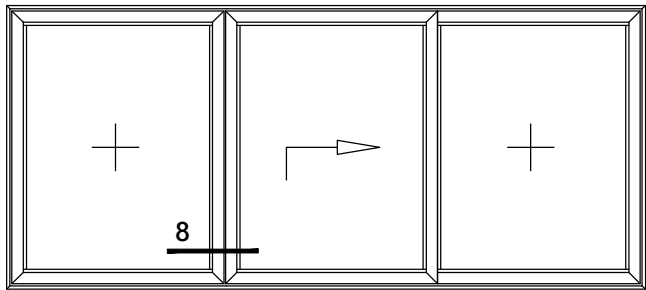

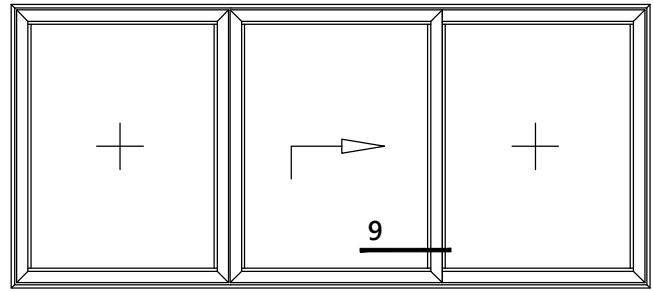
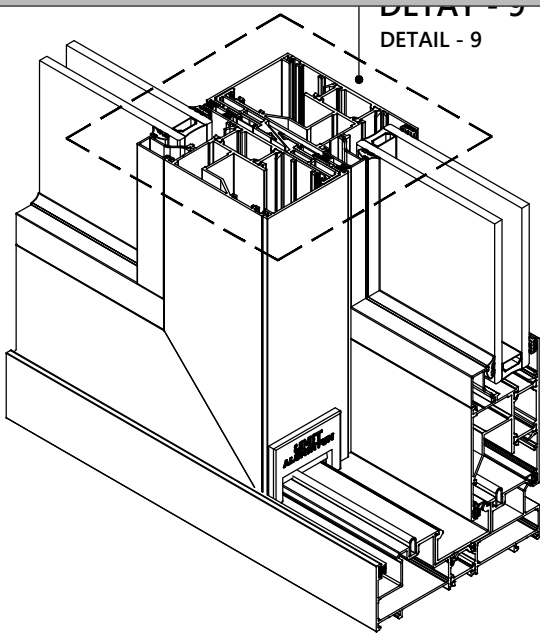

ÖLÇEK : 1/1
Scale : 1/1

DETAY - 9
DETAIL - 9

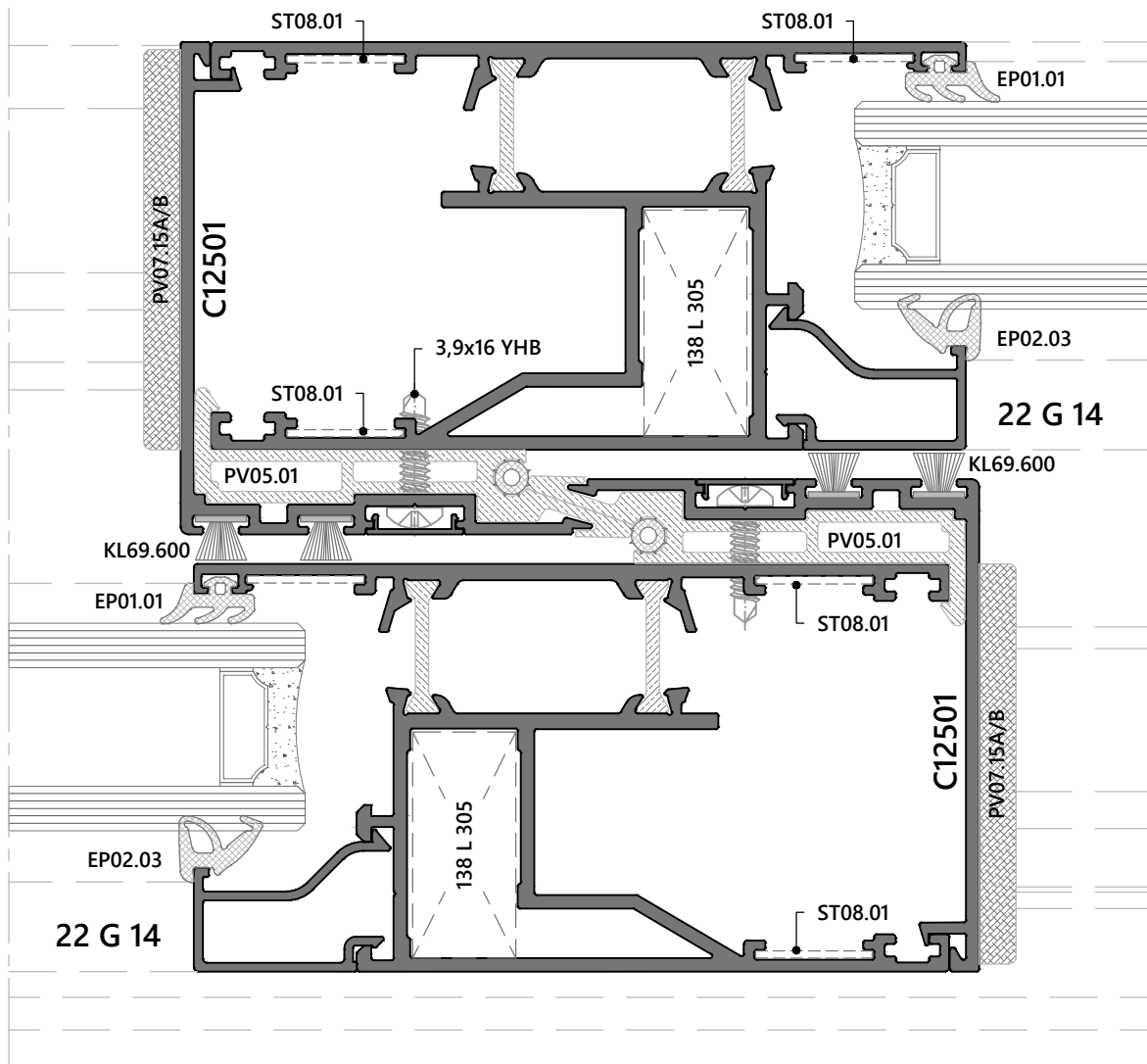

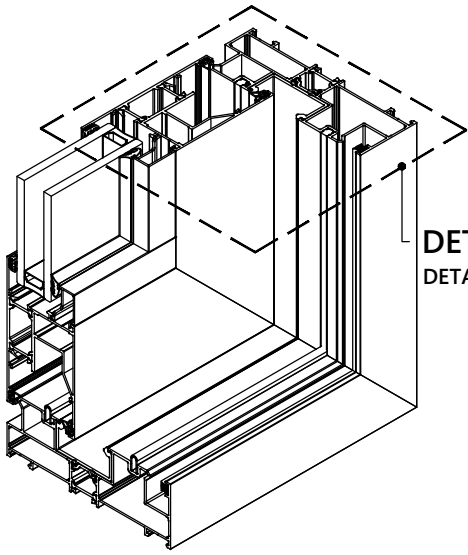

DETAJ - 10
DETAIL - 10

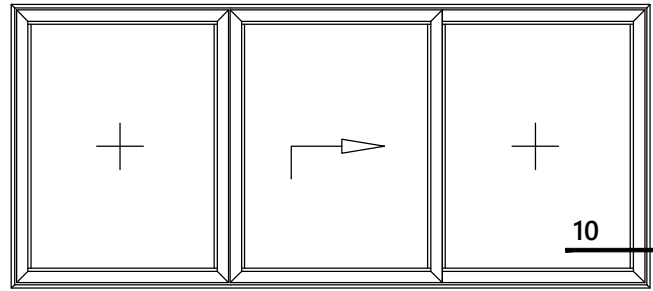

ÖLÇEK : 1/1
Scale : 1/1

DETAJ - 10
DETAIL - 10

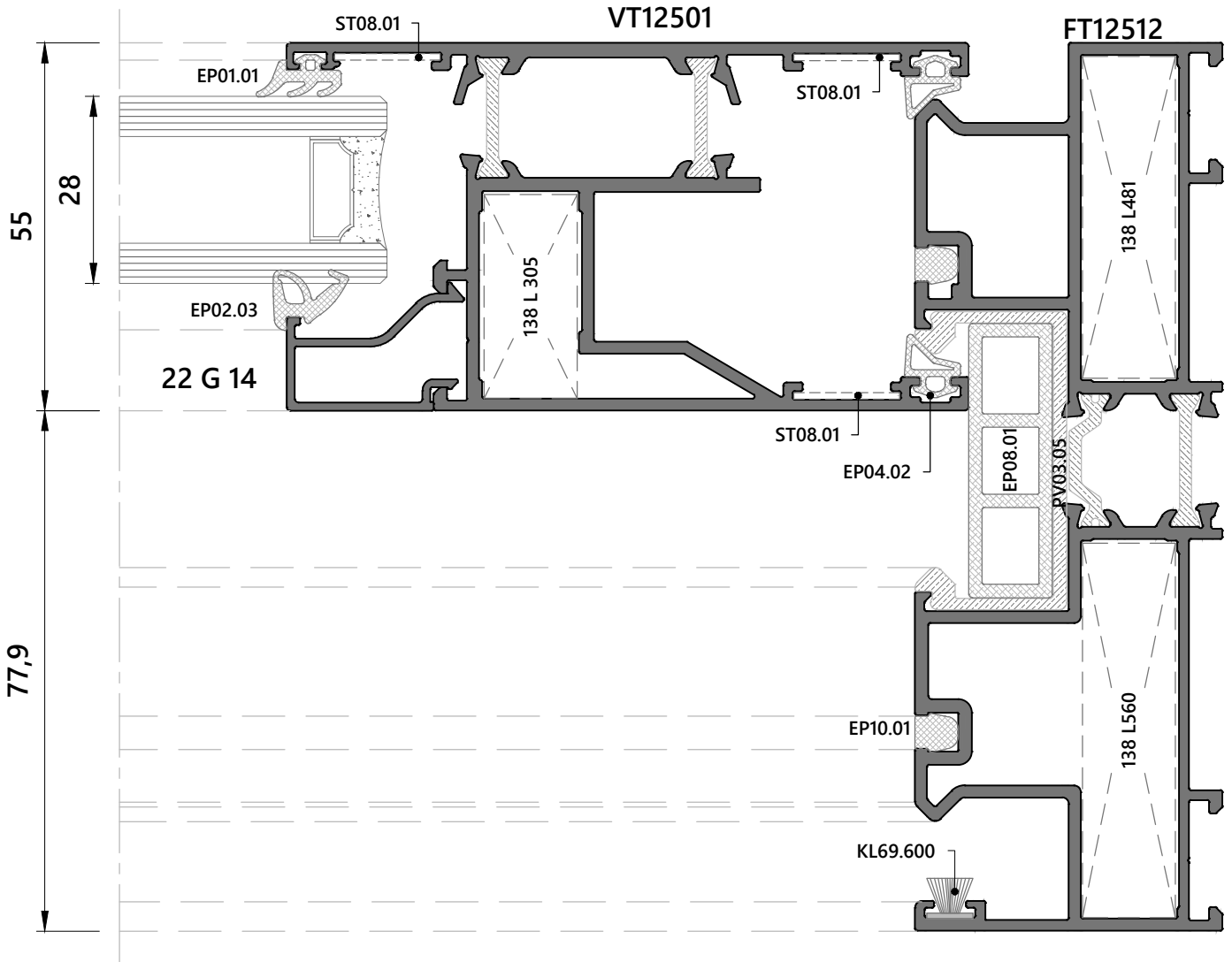

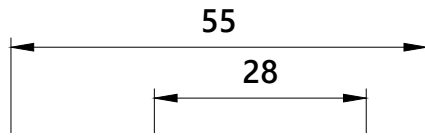
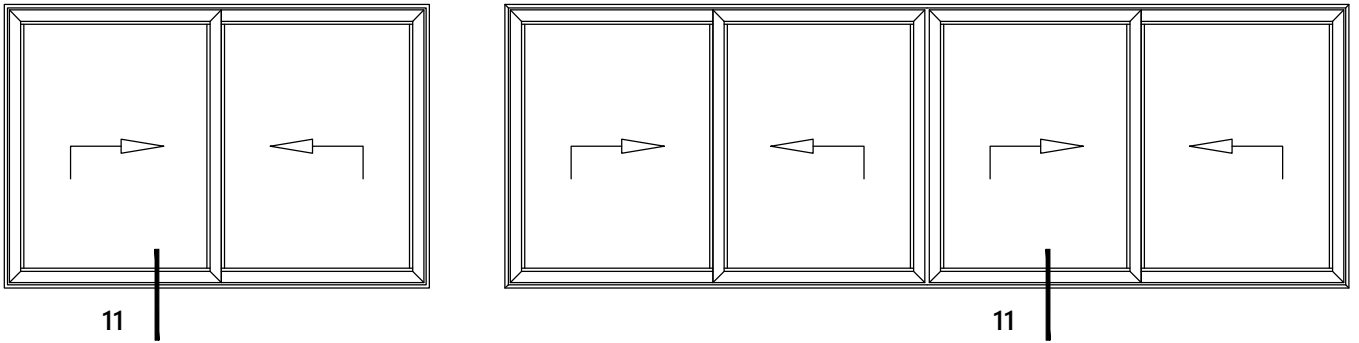

ÖLÇEK : 1/1
Scale : 1/1

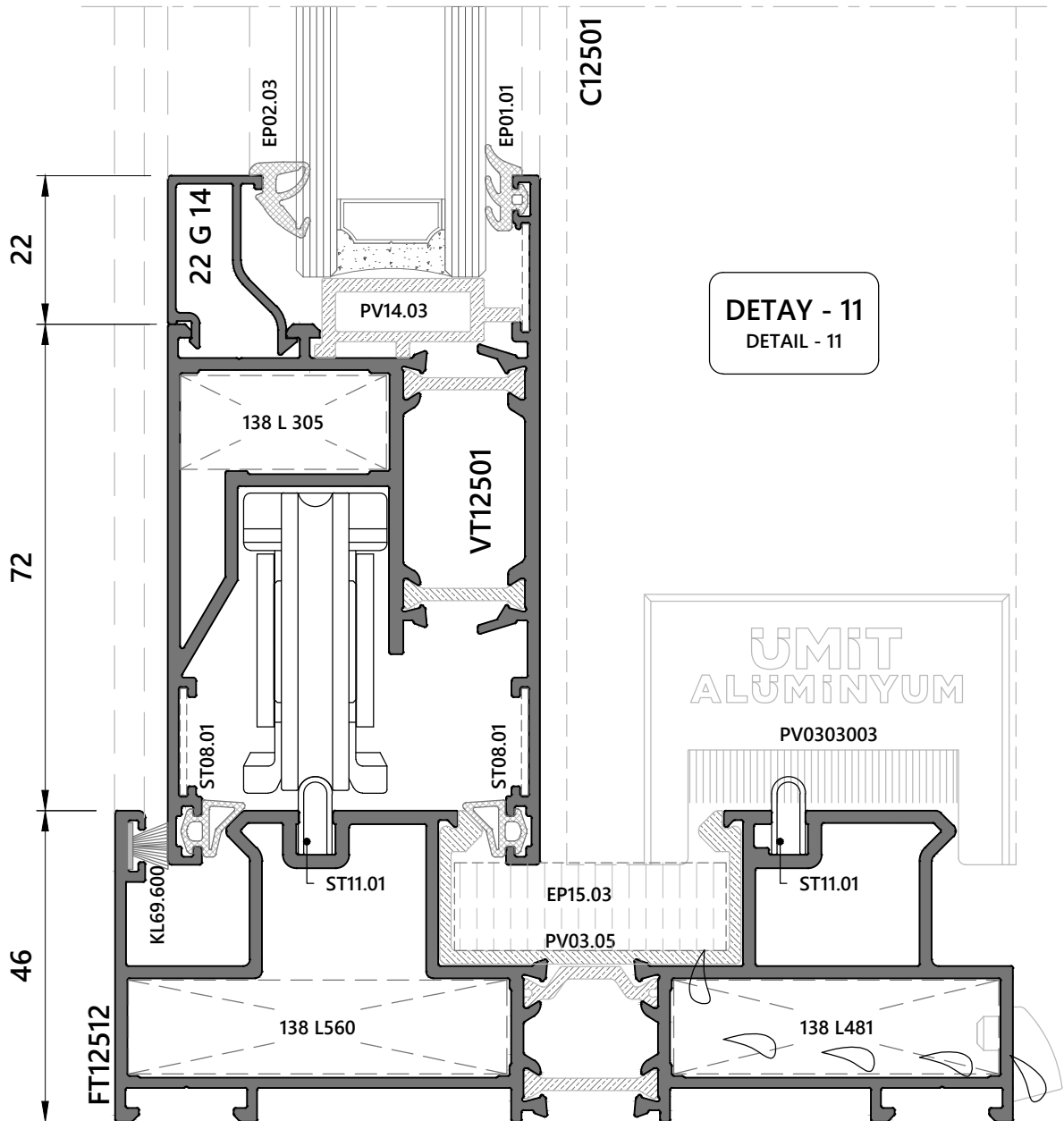

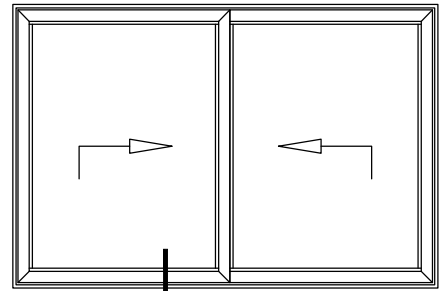
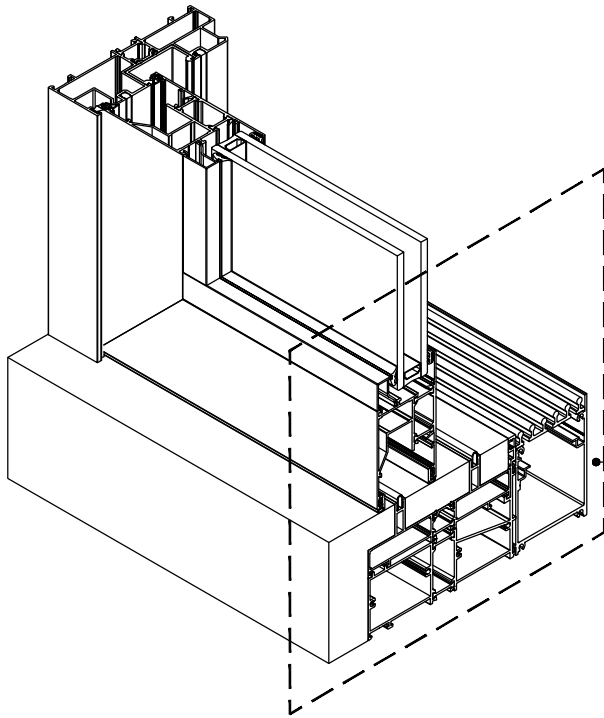

11a

DETAY-11a
DETAIL-11a

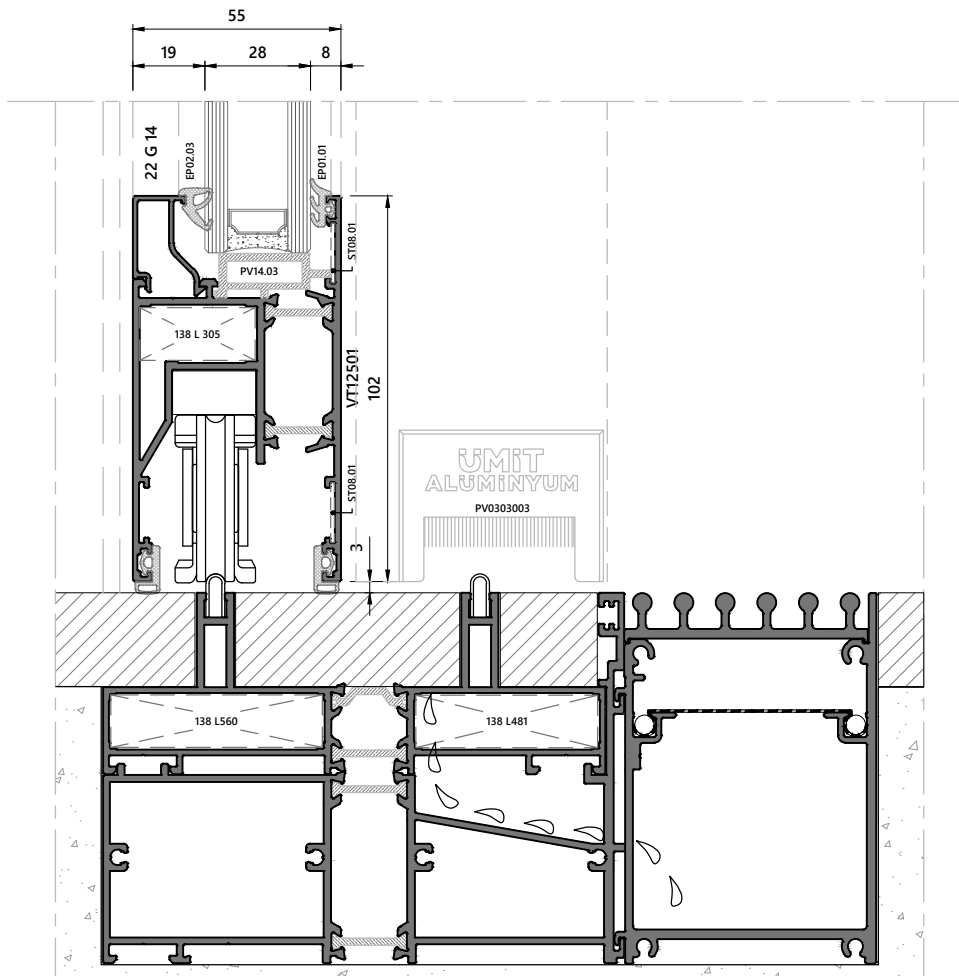

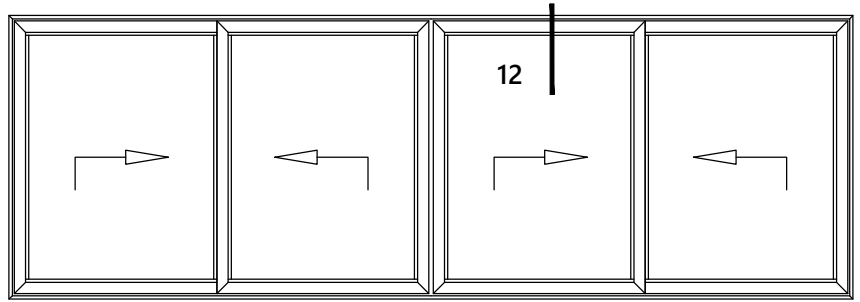
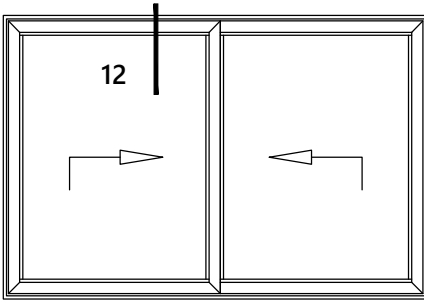

ÖLÇEK : 1/1
Scale : 1/1

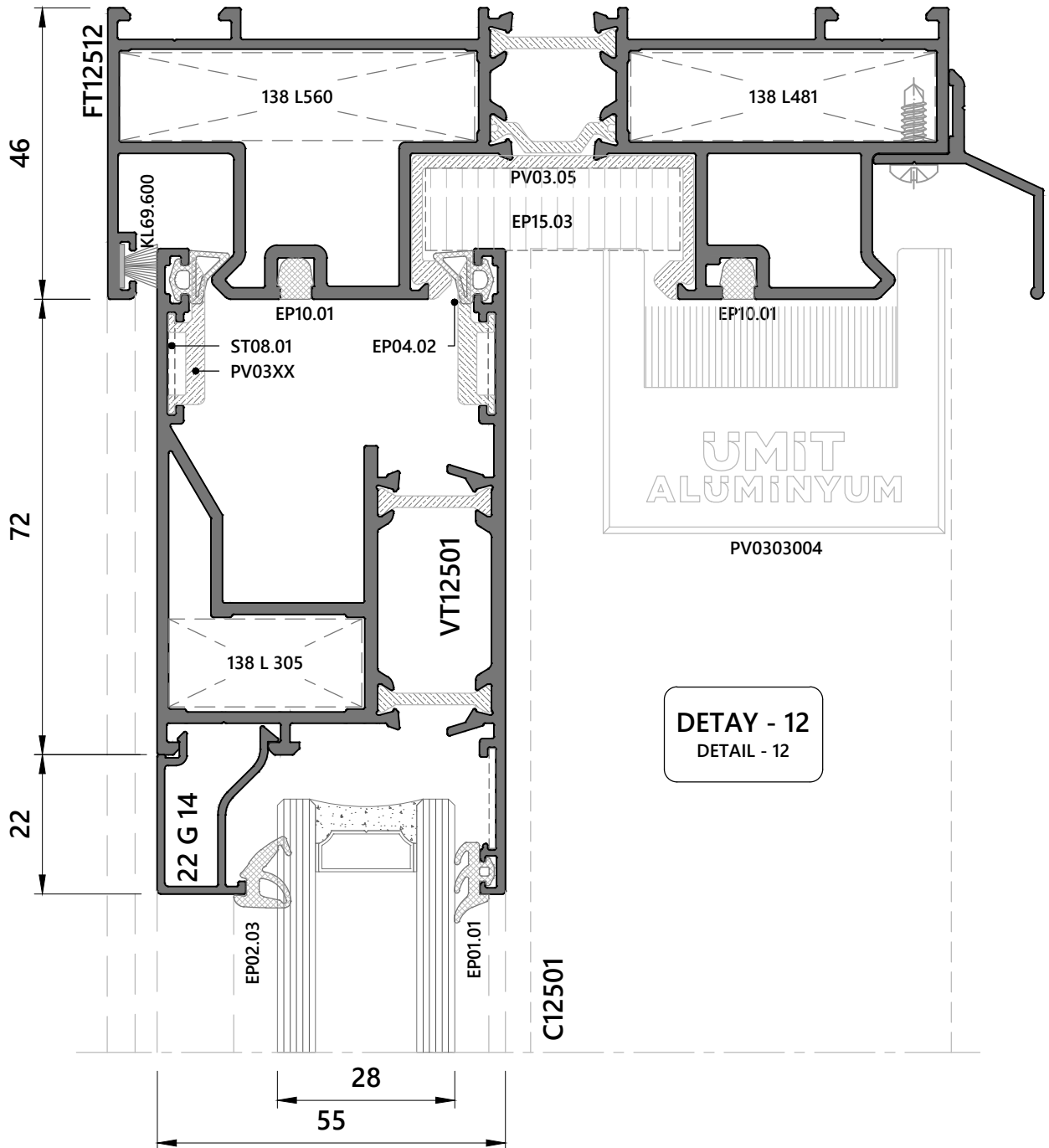

DETAY - 12
DETAIL - 12

DETAY - 12
DETAIL - 12

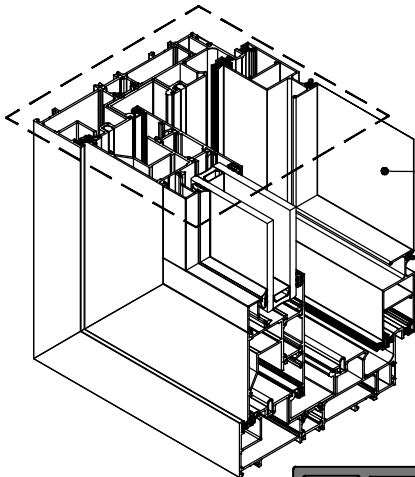

DETAY - 12
DETAIL - 12

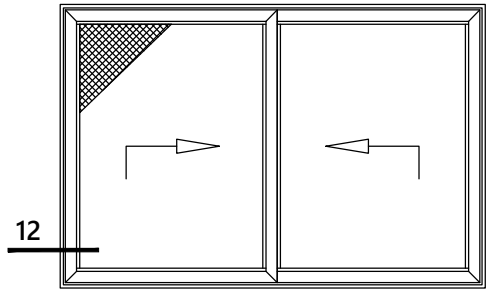

ÖLÇEK : 1/1
Scale : 1/1

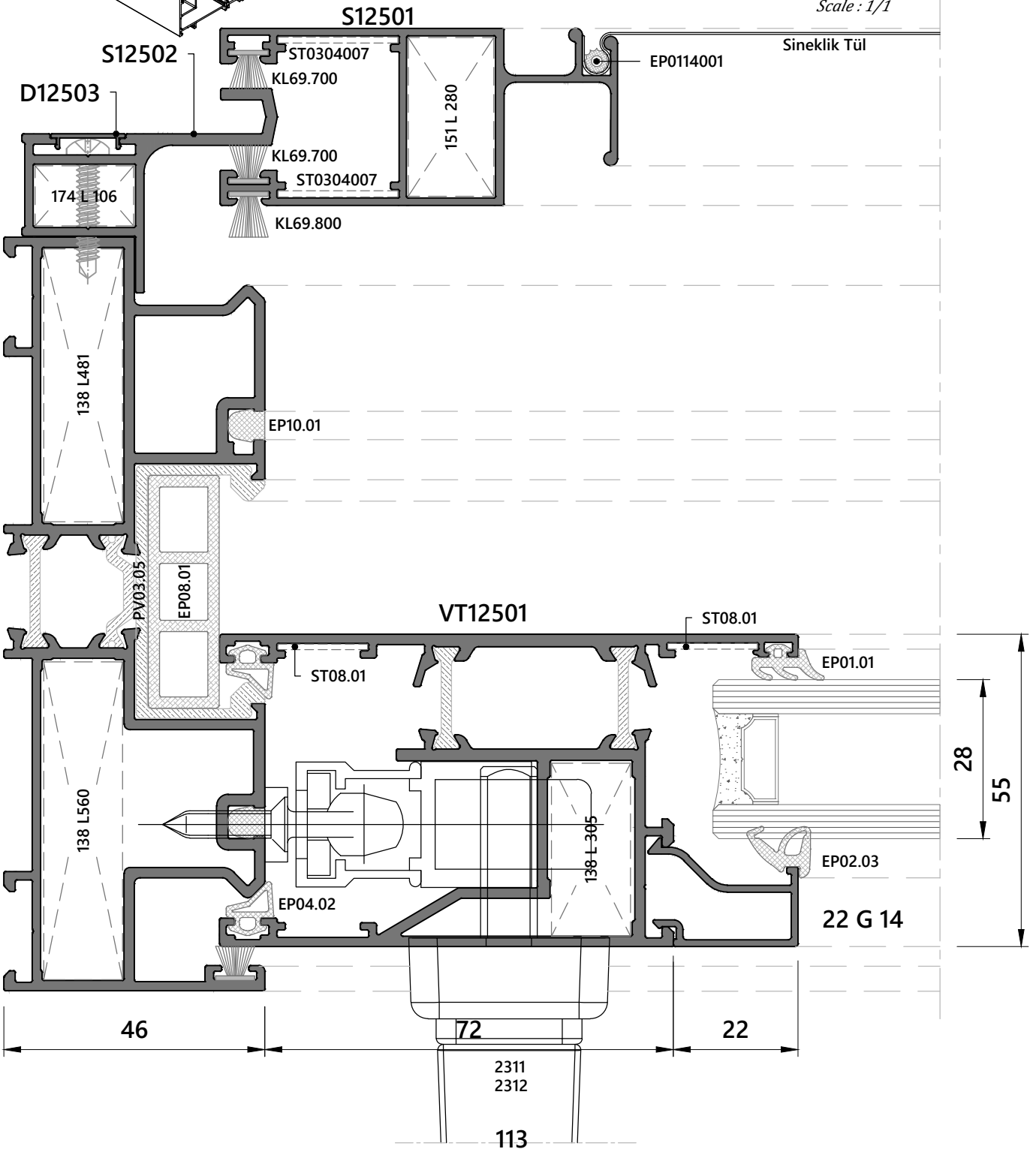

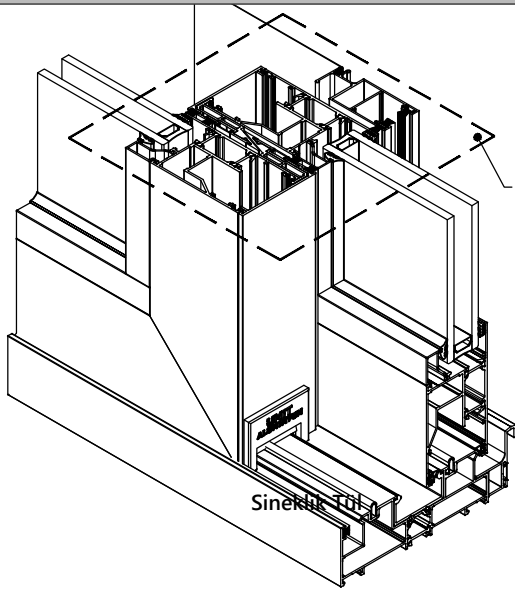

DETAY - 13
DETAIL - 13

DETAY - 13
DETAIL - 13

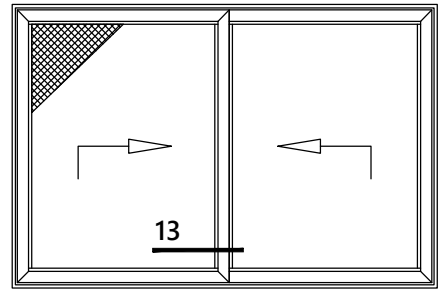

ÖLÇEK : 1/1
Scale : 1/1

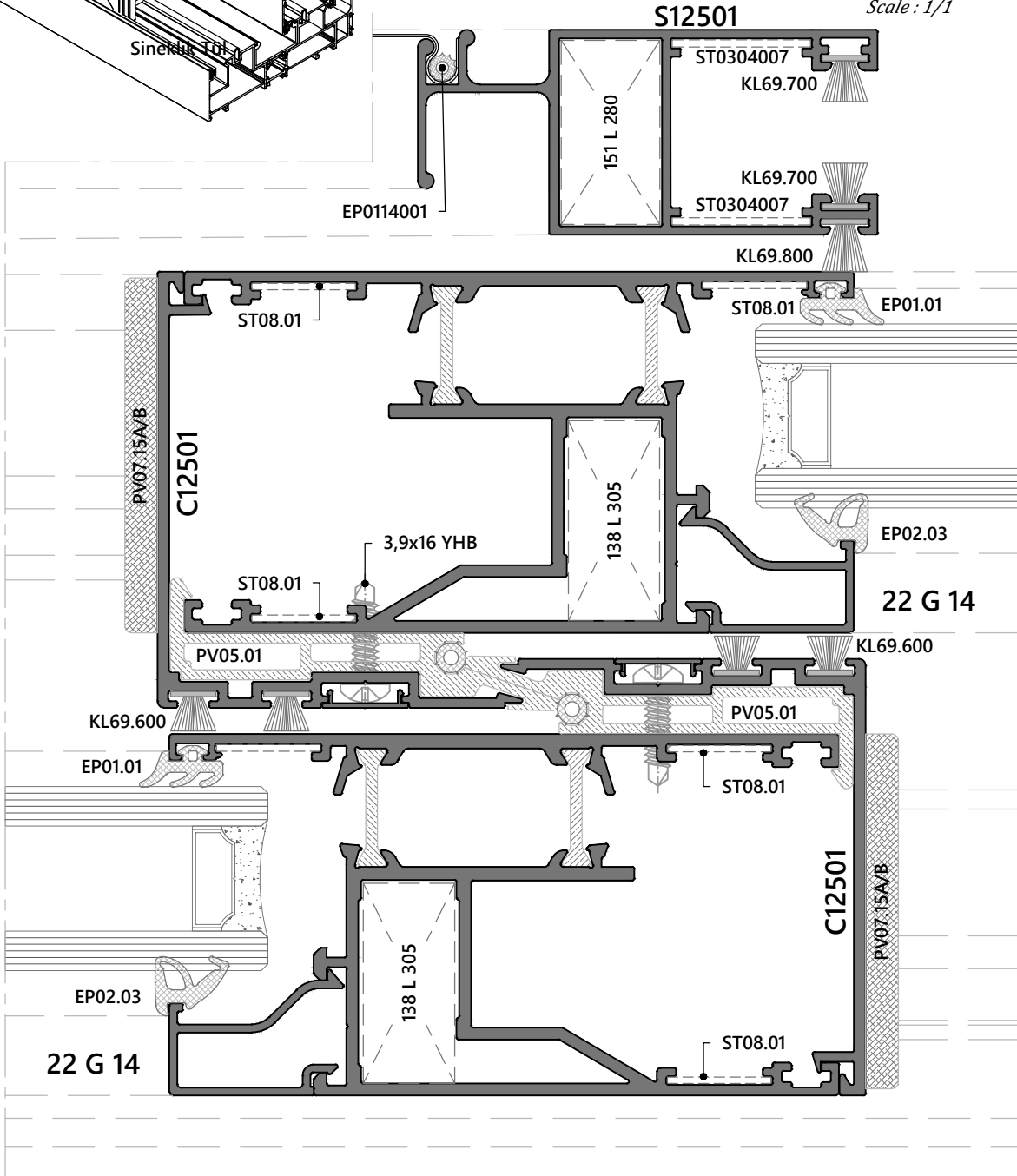

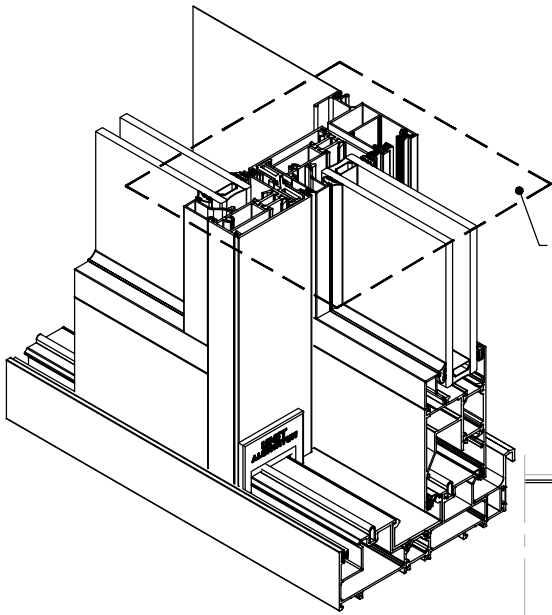

DETAY - 13a
DETAIL - 13a

DETAY - 13a
DETAIL - 13a

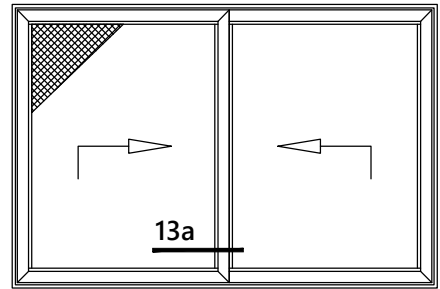

ÖLÇEK : 1/1
Scale : 1/1

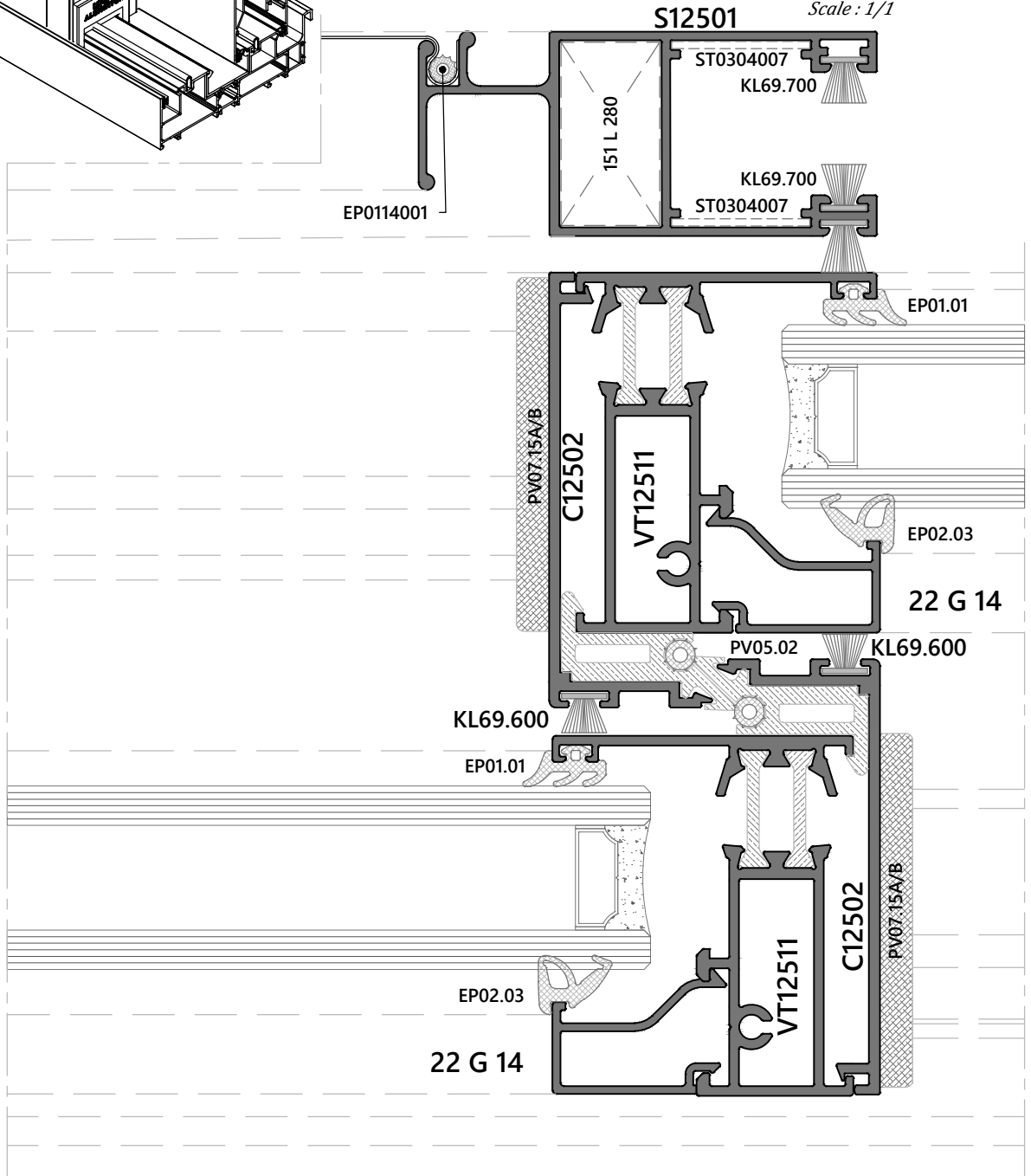

DETAY - 14
DETAIL - 14

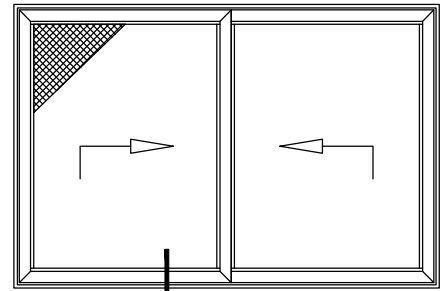
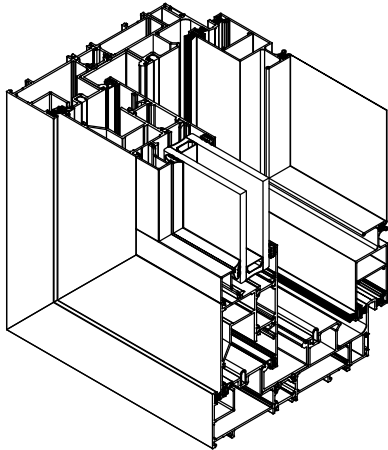

14

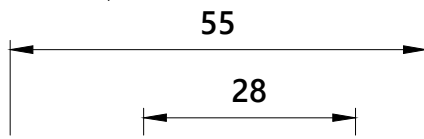

ÖLÇEK : 1/1
Scale : 1/1

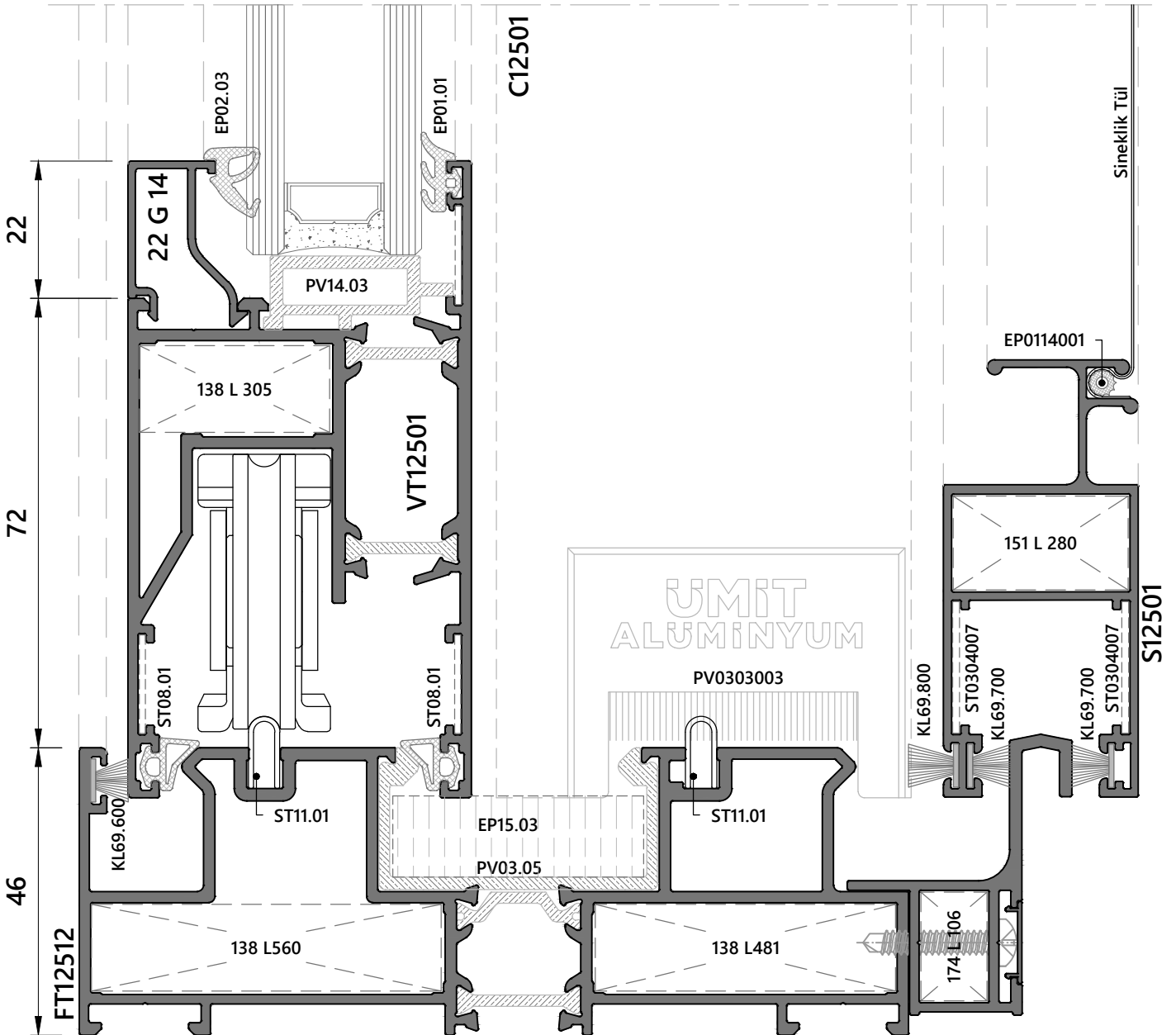

DETAY - 15
DETAY - 15

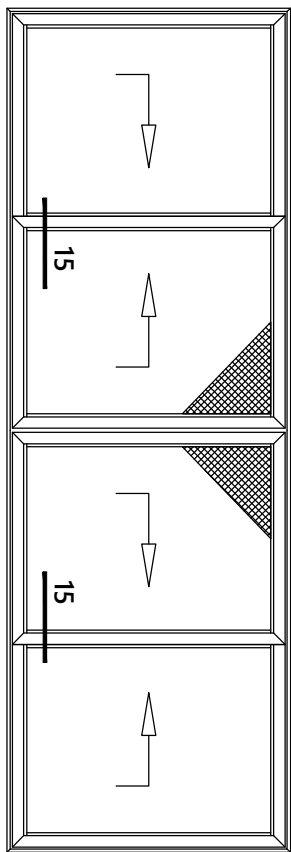

ÖLÇEK : 1/1
Scale : 1/1

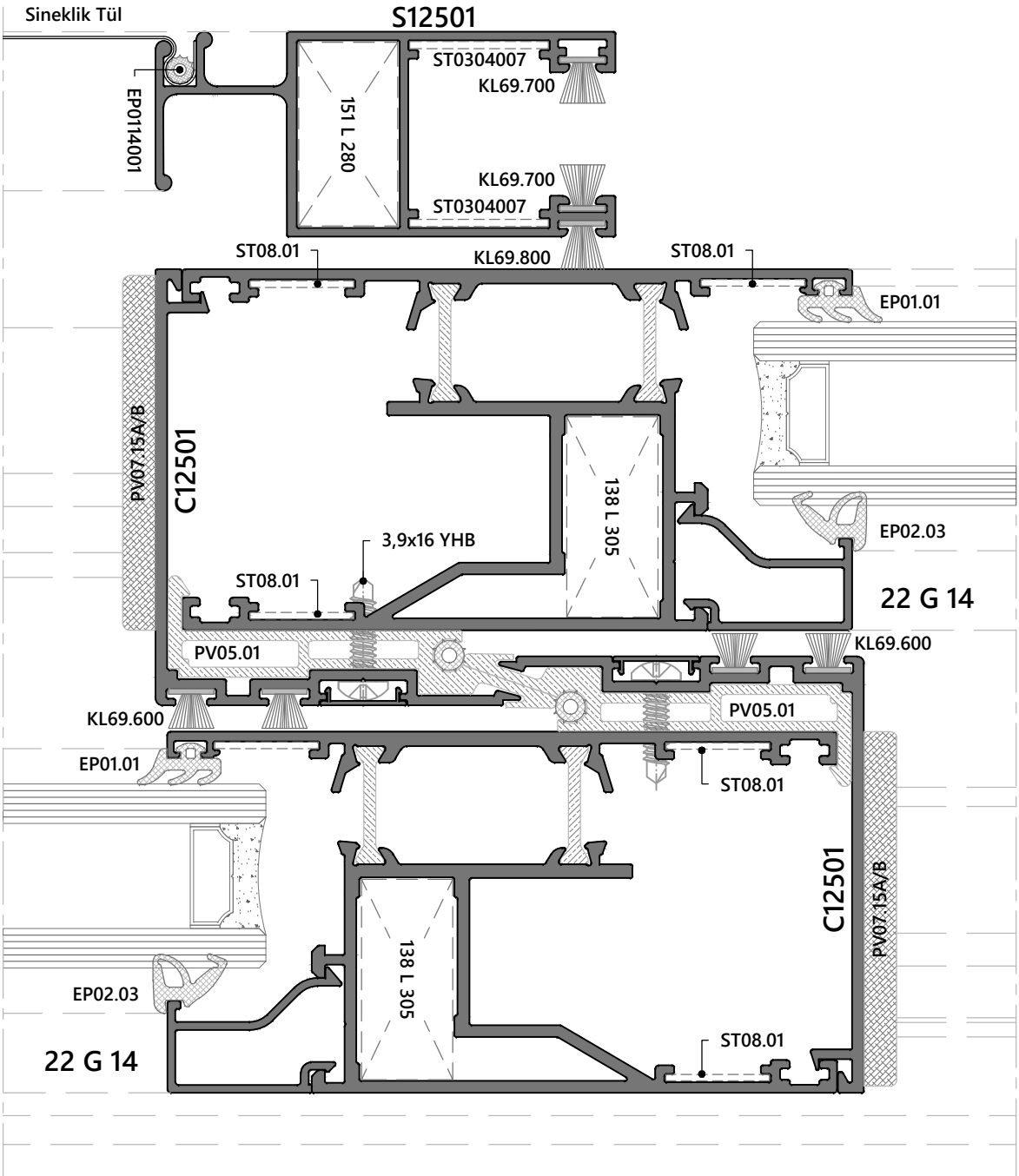

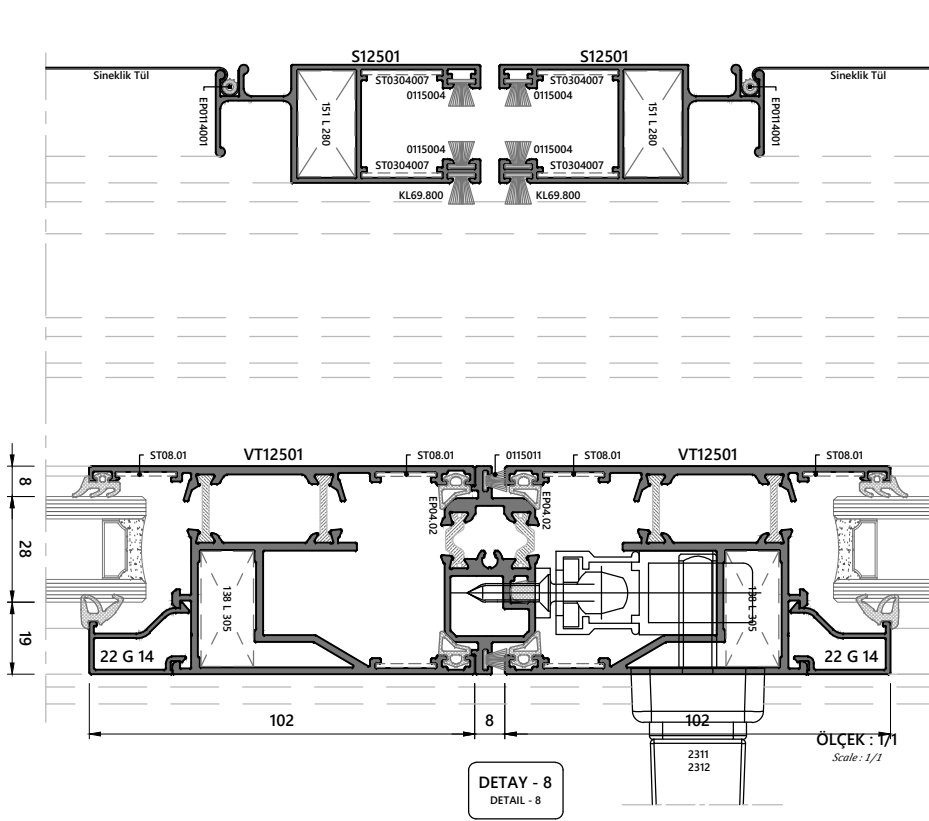
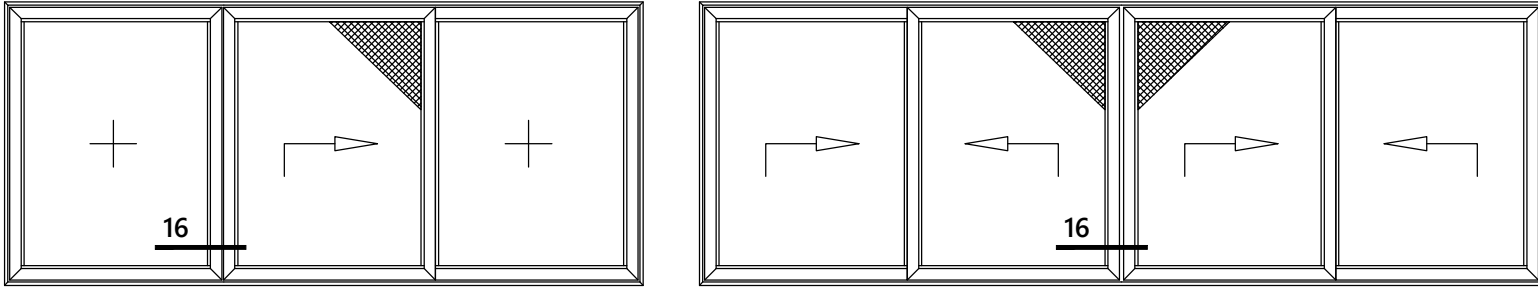

DETAY - 15
DETAIL - 15

ÖLÇEK : 1/2
Scale : 1/2

DETAY - 8
DETAIL - 8

ÖLÇEK : 1/1
Scale : 1/1

KLASİK SÜRME AÇILIM TİPLERİ

SLIDING TYPES OF OPENING

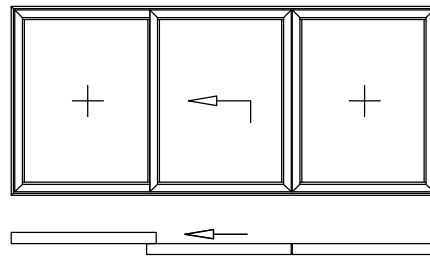
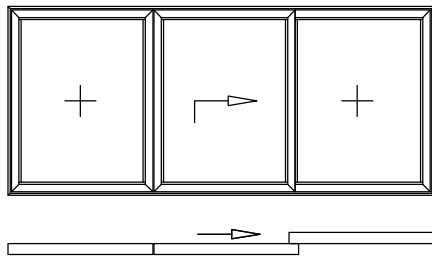
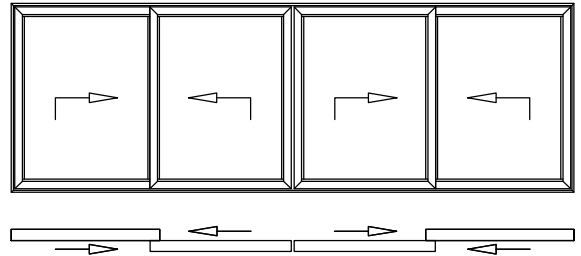
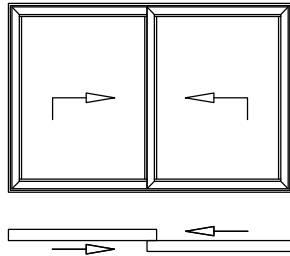
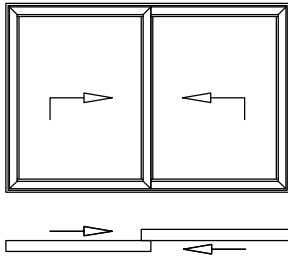
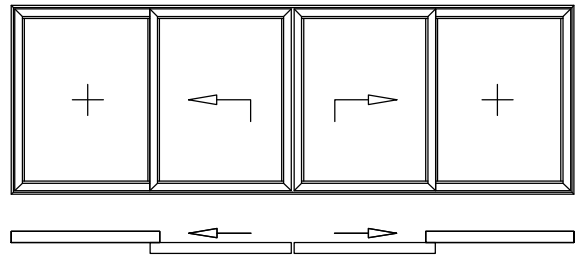
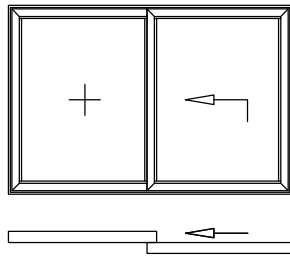
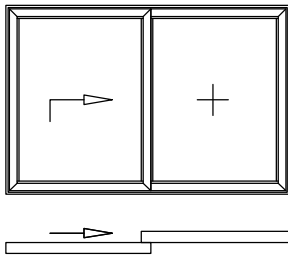

DETAY - 1
DETAIL - 1

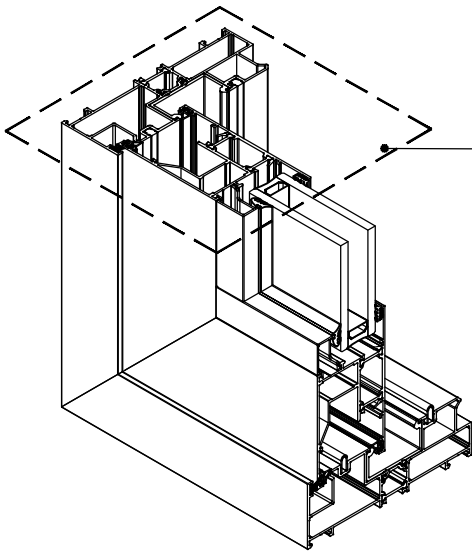

DETAY - 1
DETAIL - 1

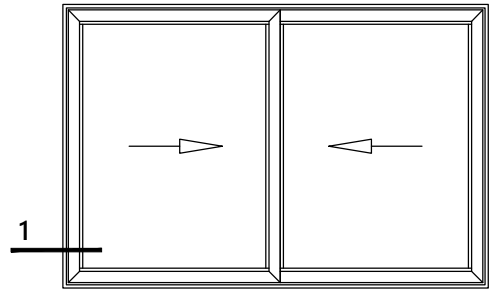

ÖLÇEK : 1/1
Scale : 1/1

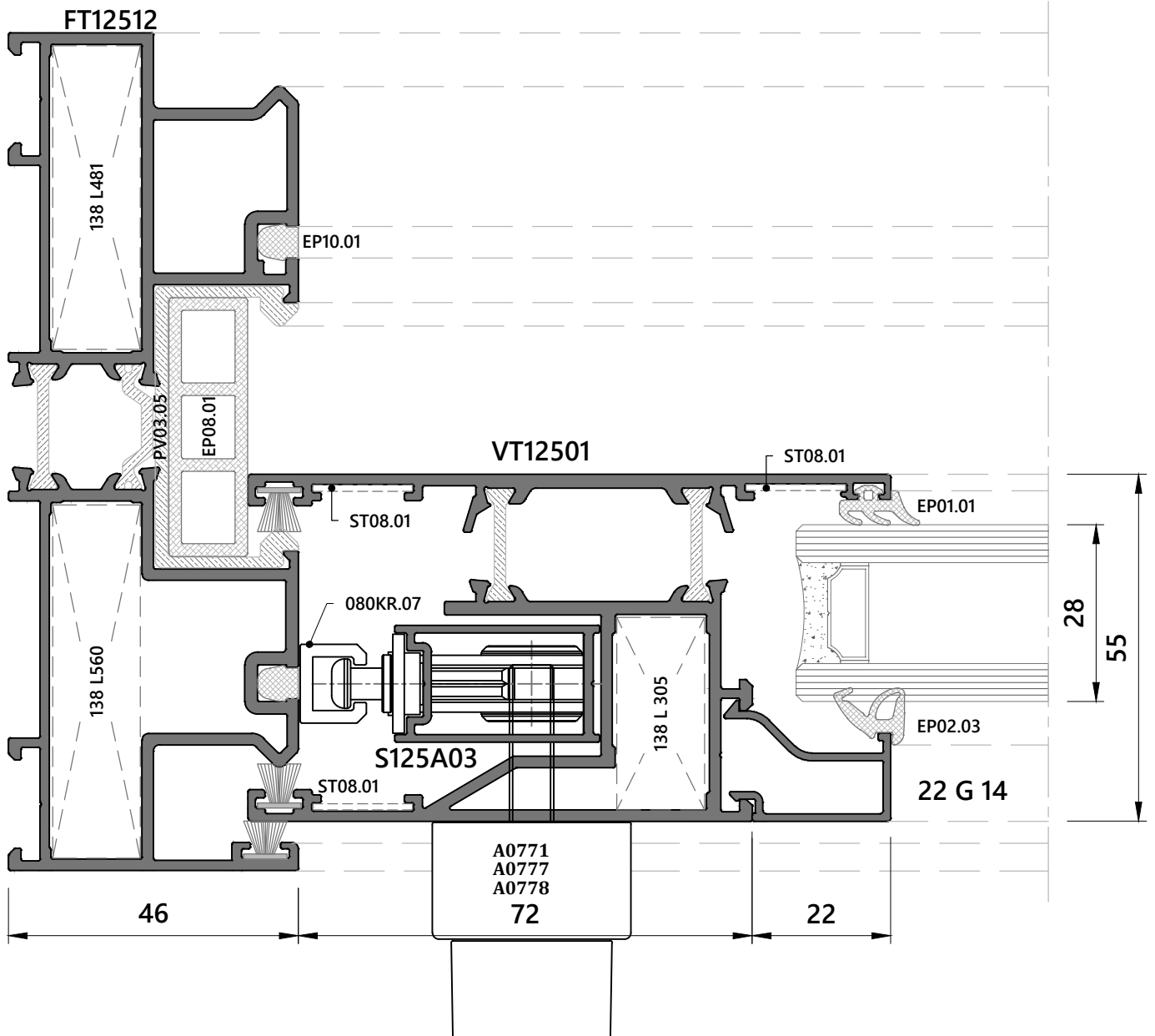

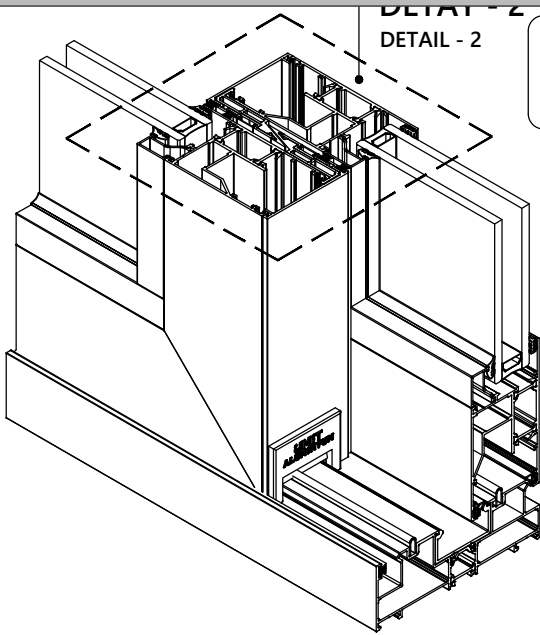

DETAIL - 2
DETAIL - 2

DETAIL - 2
DETAIL - 2

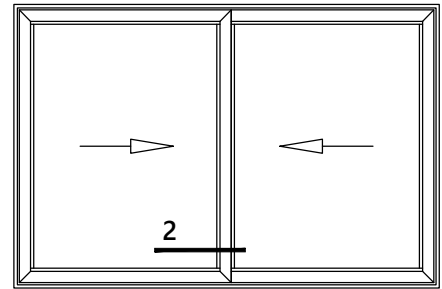

ÖLÇEK : 1/1
Scale : 1/1

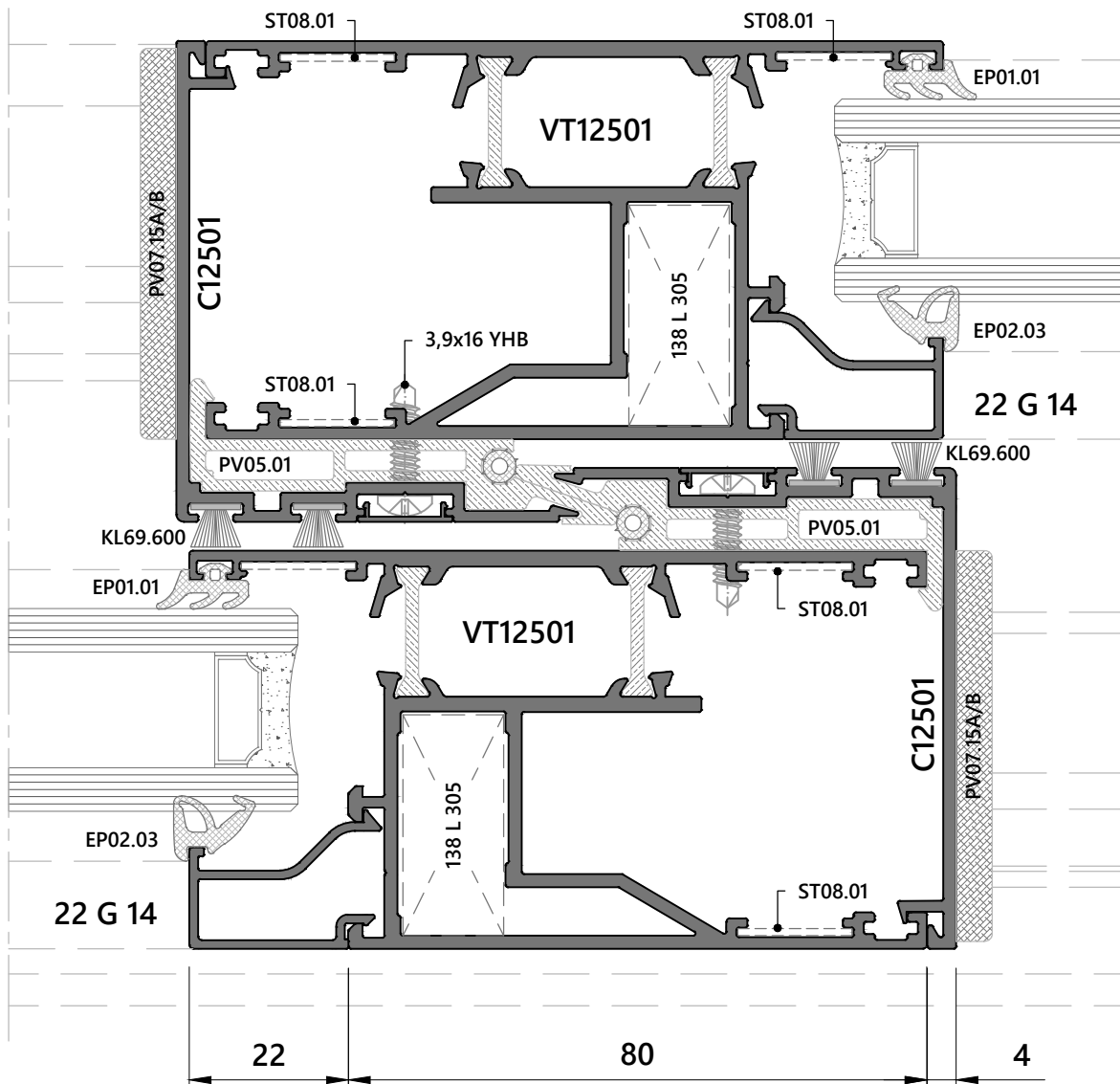

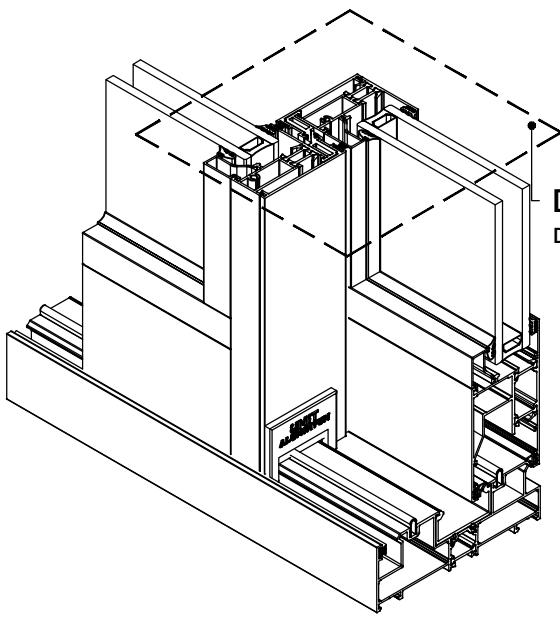

DETAY - 2a
DETAIL - 2a

DETAY - 2a
DETAIL - 2a

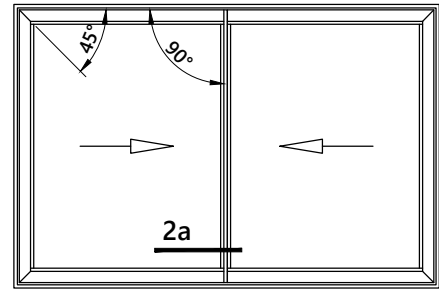

ÖLÇEK : 1/1
Scale : 1/1

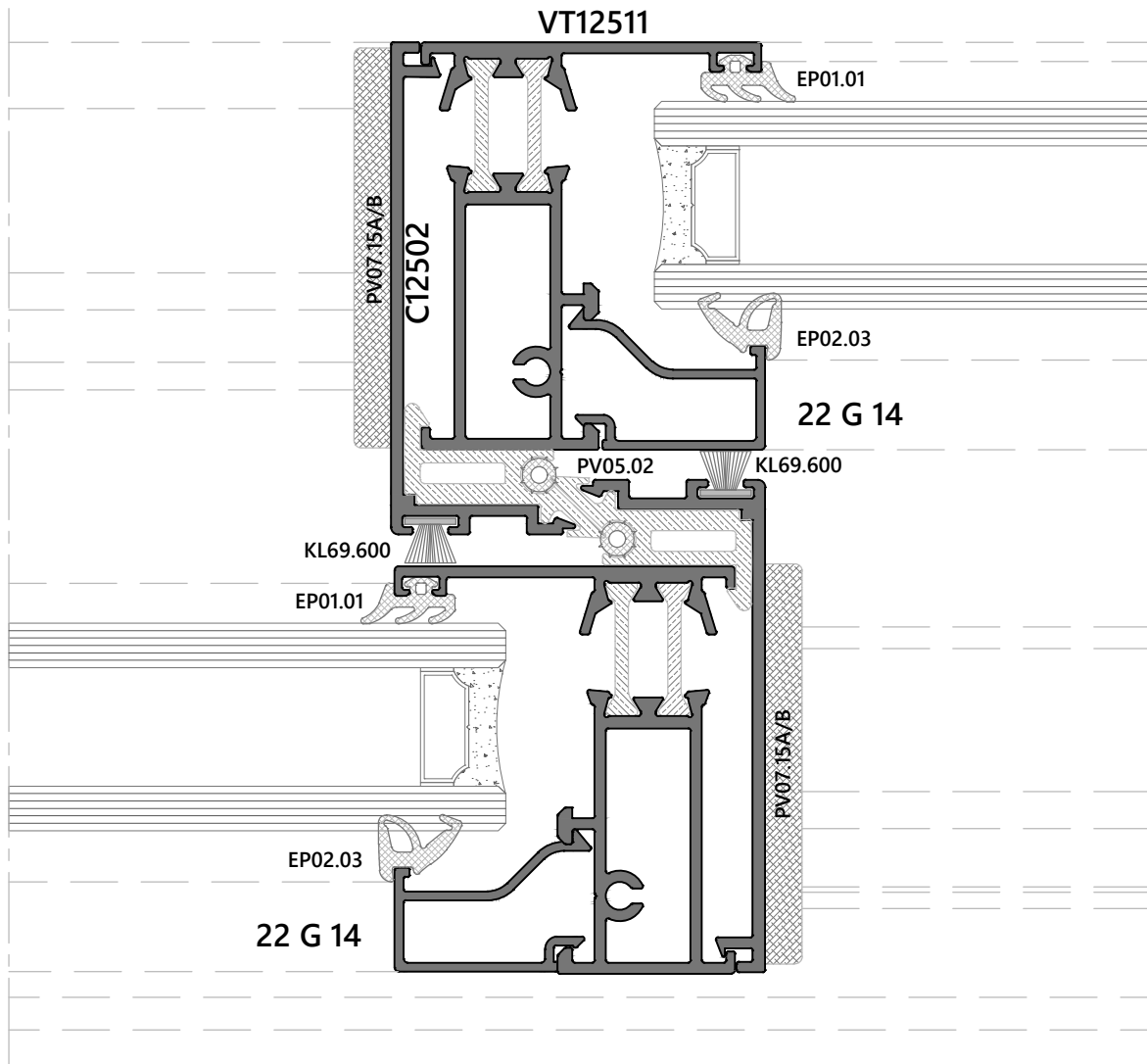

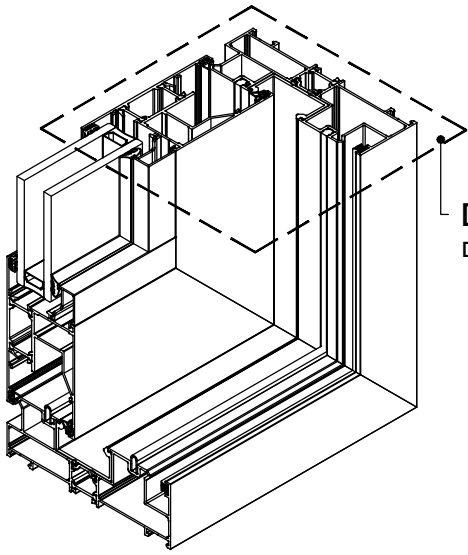

DETAY - 3
DETAIL - 3

DETAY - 3
DETAIL - 3

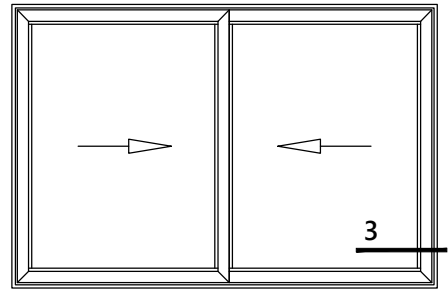

ÖLÇEK : 1/1
Scale : 1/1

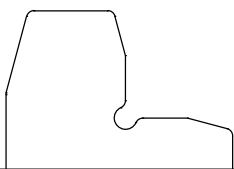
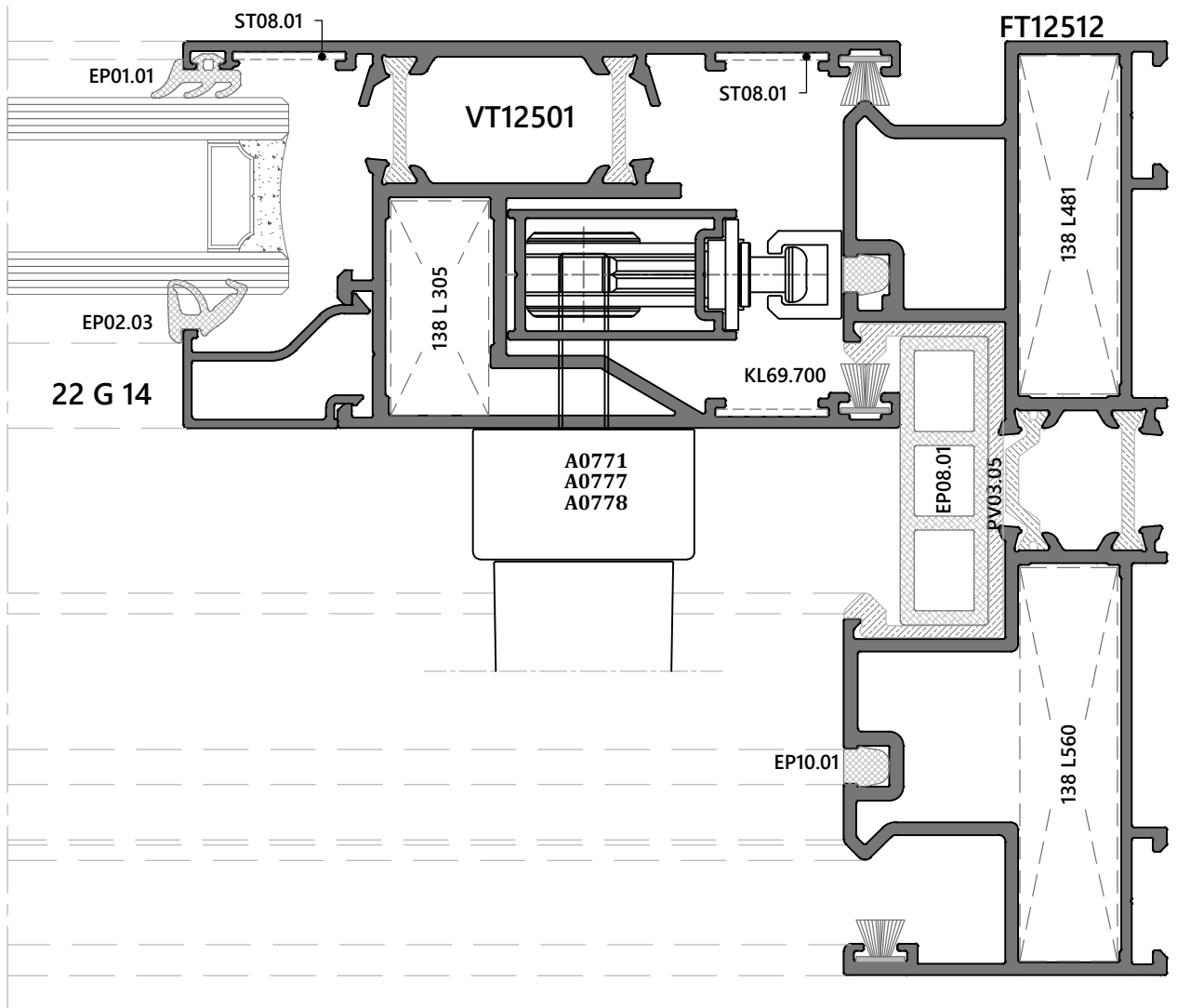

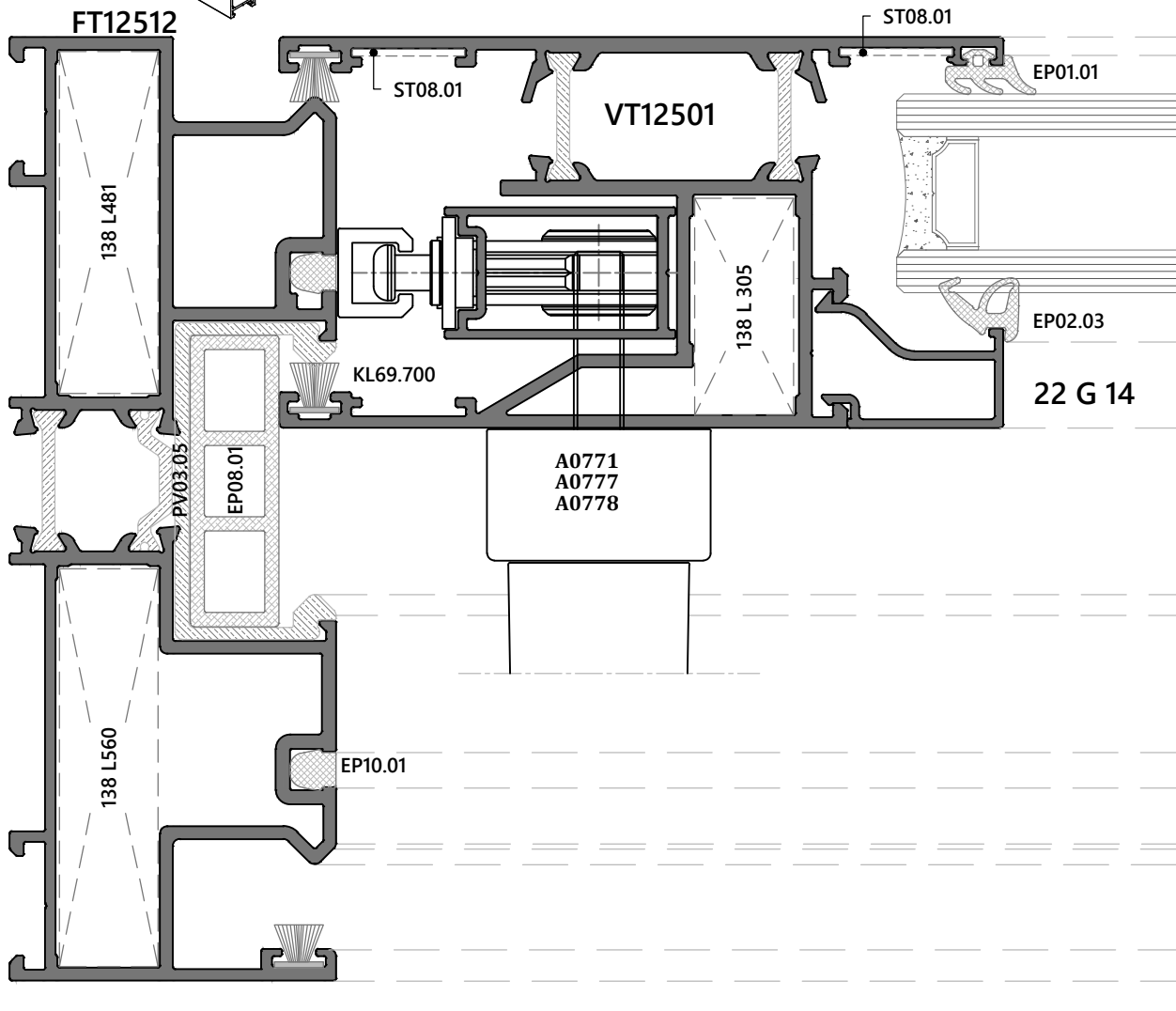
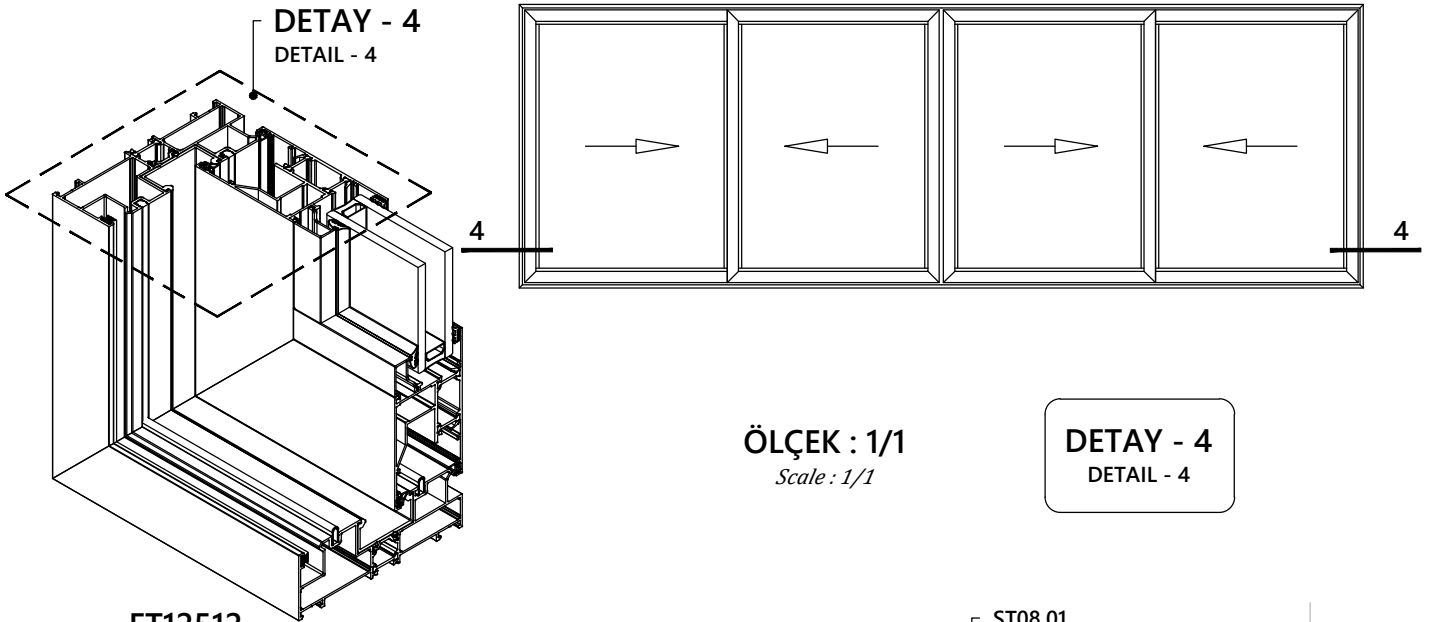

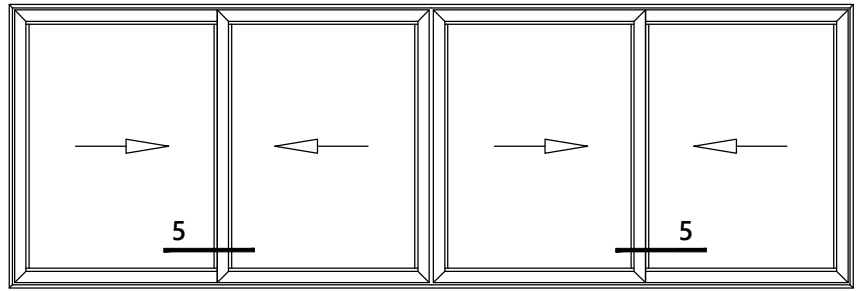
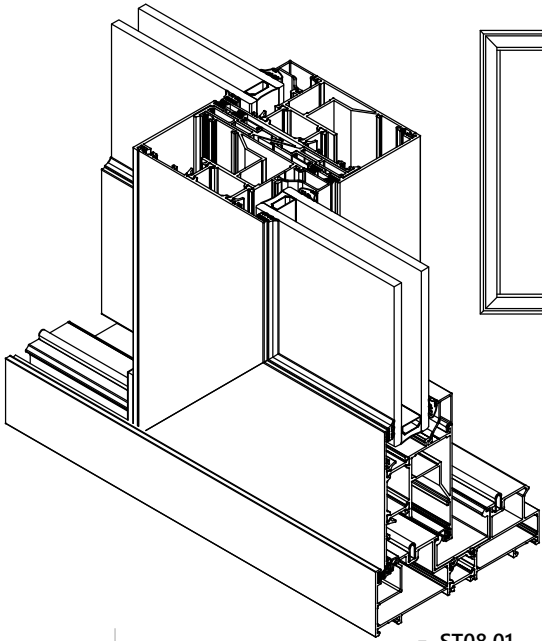

ÖLÇEK : 1/1
Scale : 1/1

DETAY - 5
DETAIL - 5

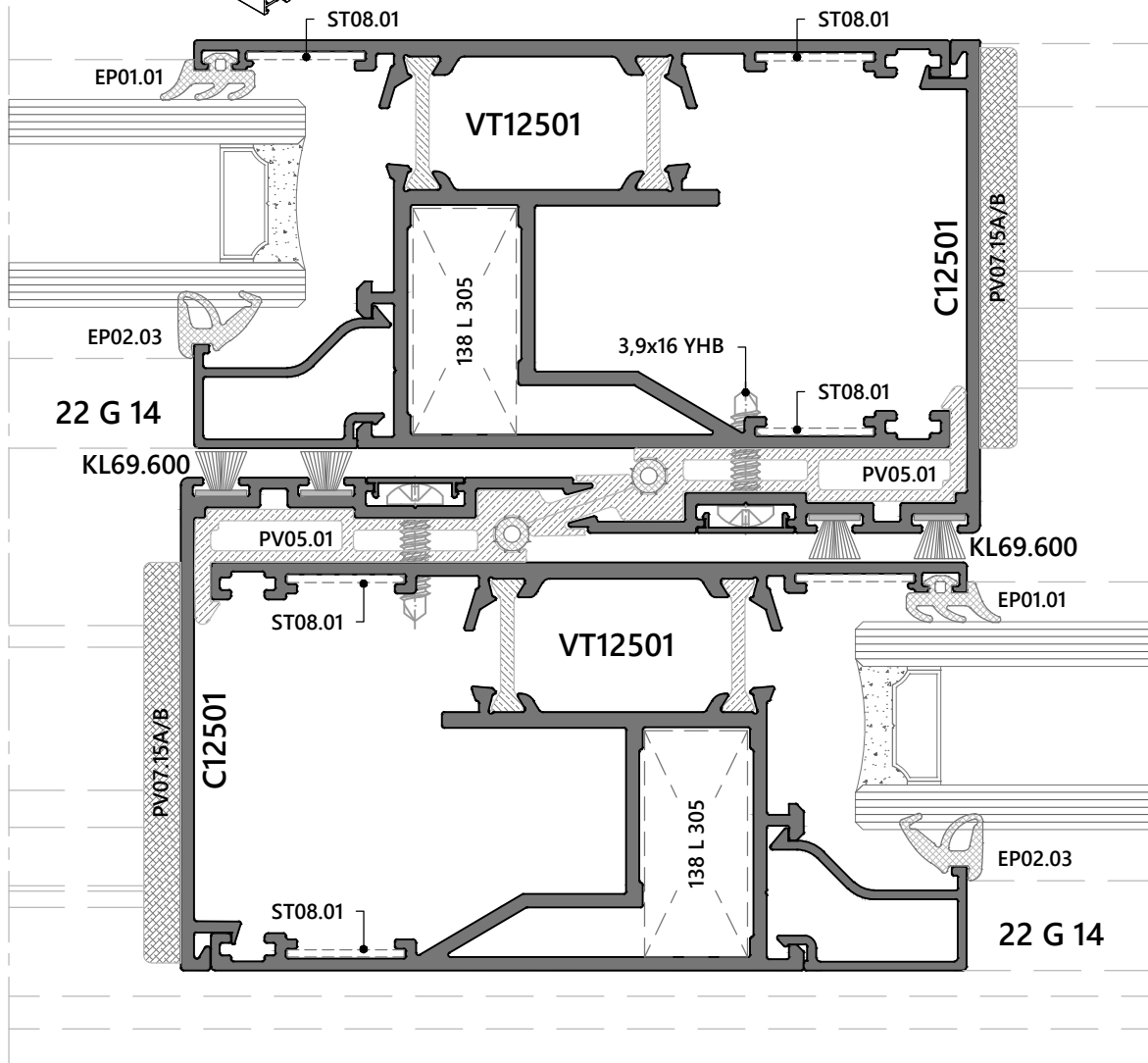

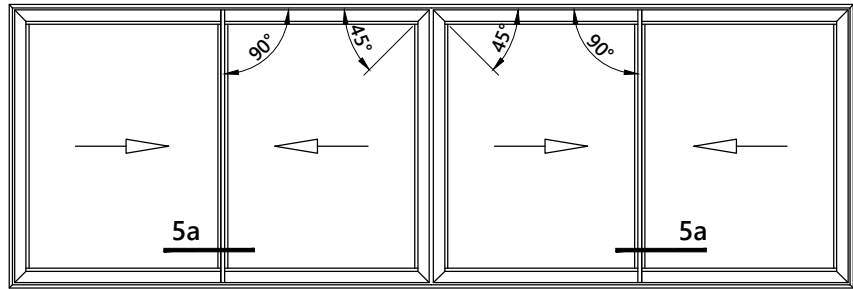

ÖLÇEK : 1/1
Scale : 1/1

DETAY - 5a
DETAIL - 5a

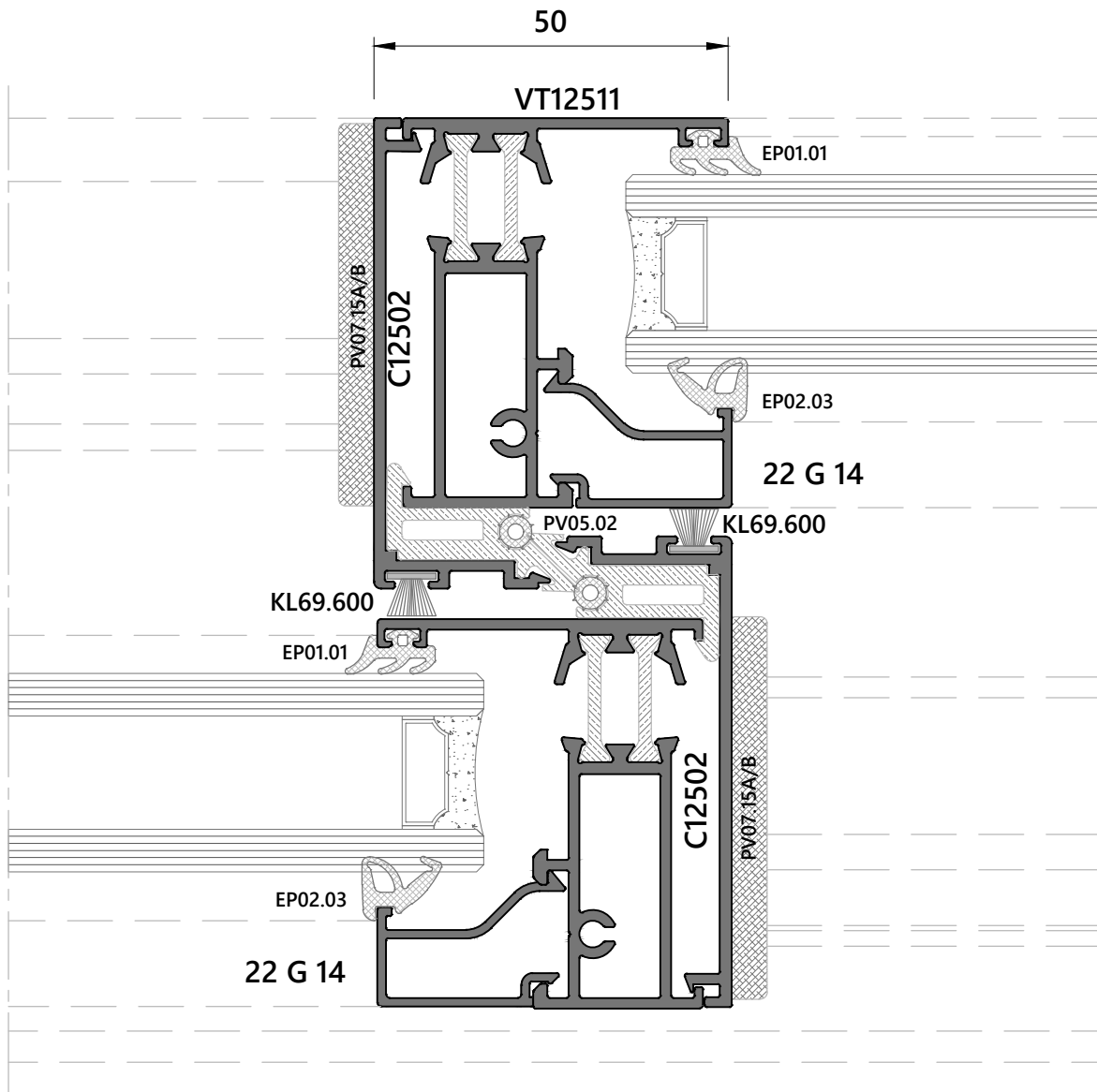

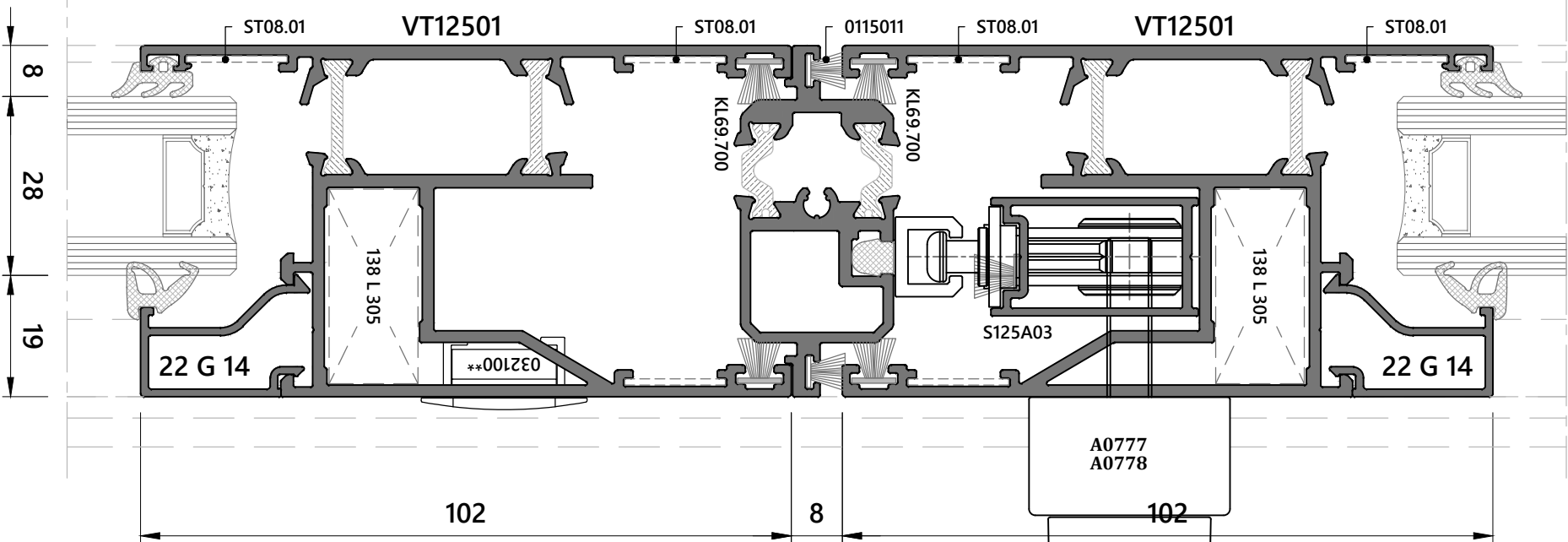
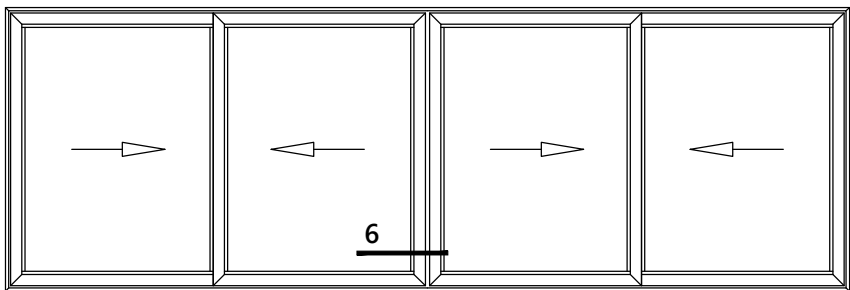

DETAIL - 6
DETAIL - 6

ÖLÇEK : 1/1
Scale : 1/1

127

8

28

19

102

8

102

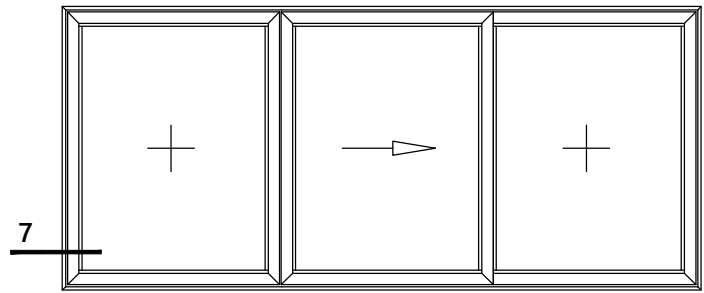
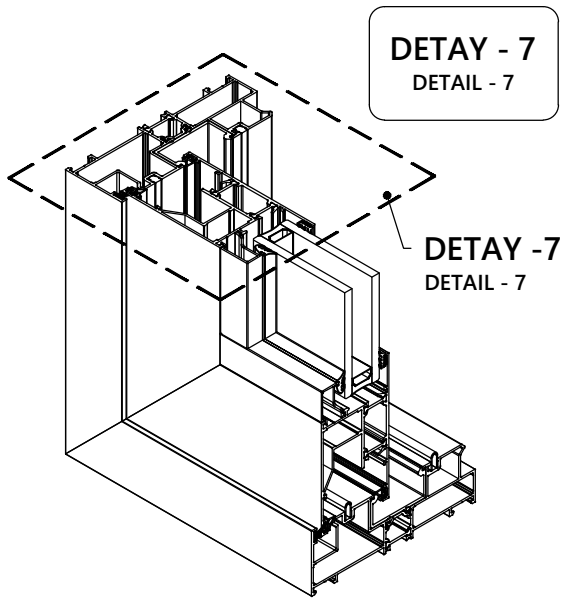

ÖLÇEK : 1/1
Scale : 1/1

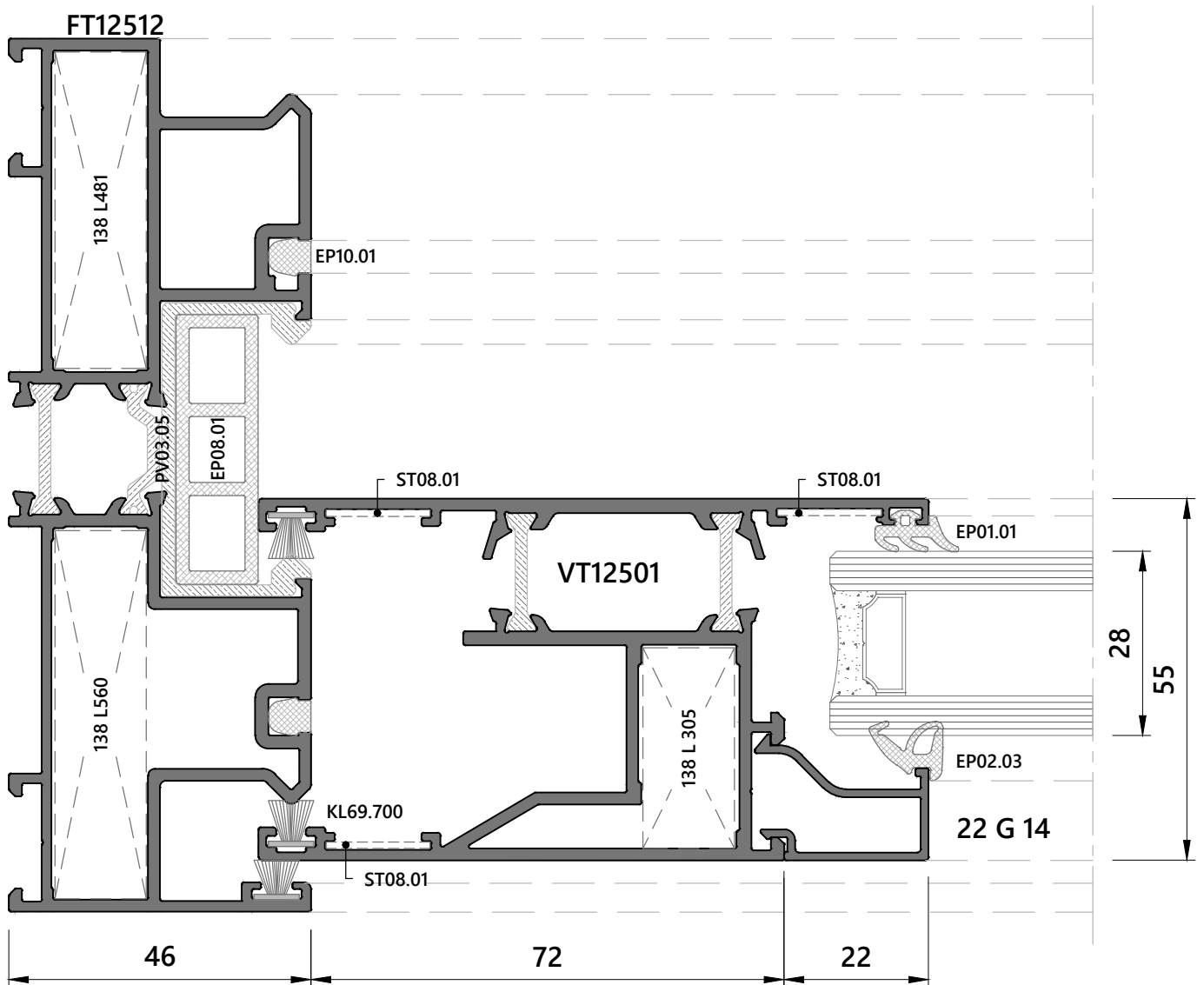

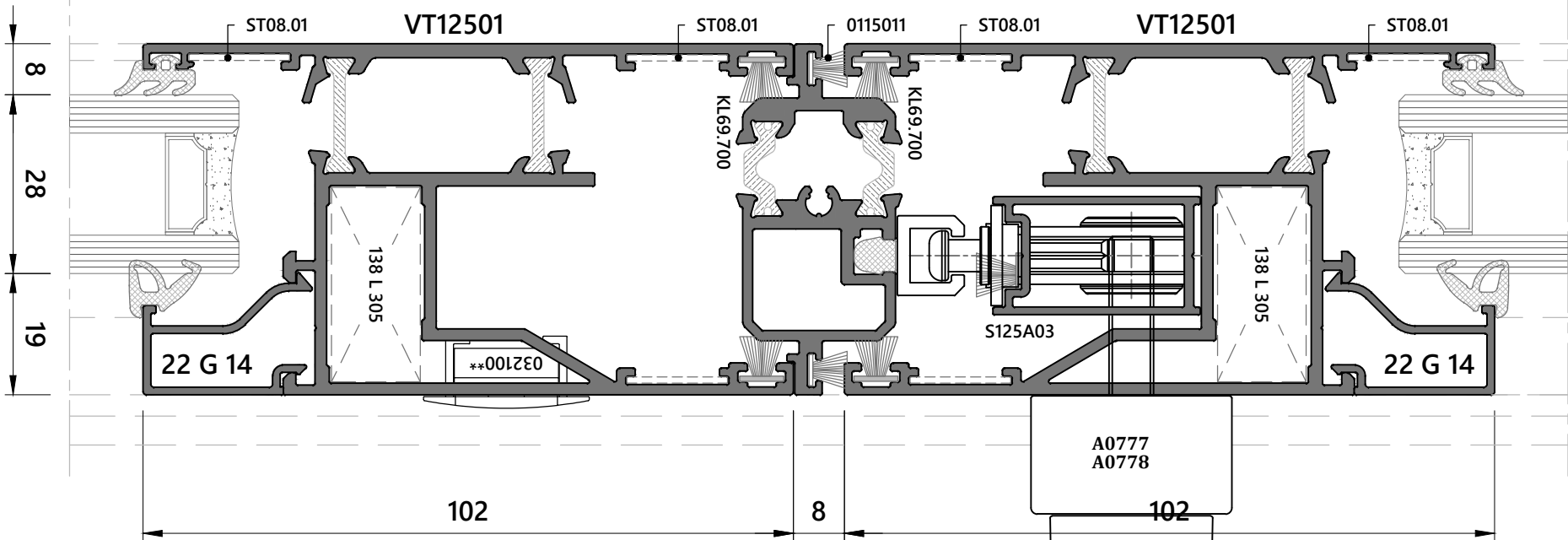
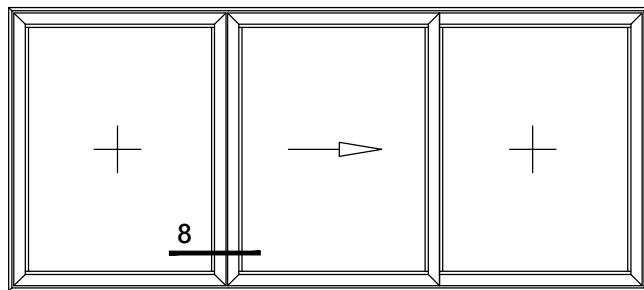

DETAY - 8
DETAIL - 8

ÖLÇEK : 1/1
Scale : 1/1

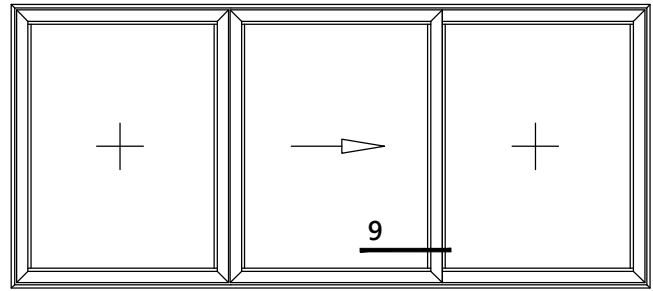
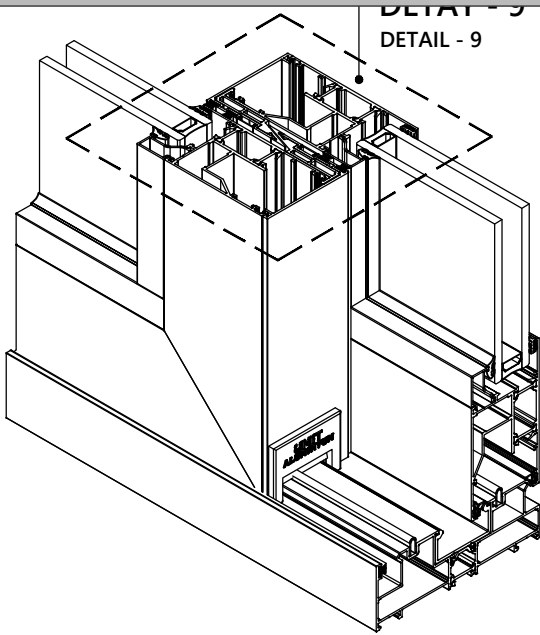

ÖLÇEK : 1/1
Scale : 1/1

DETAY - 9
DETAIL - 9

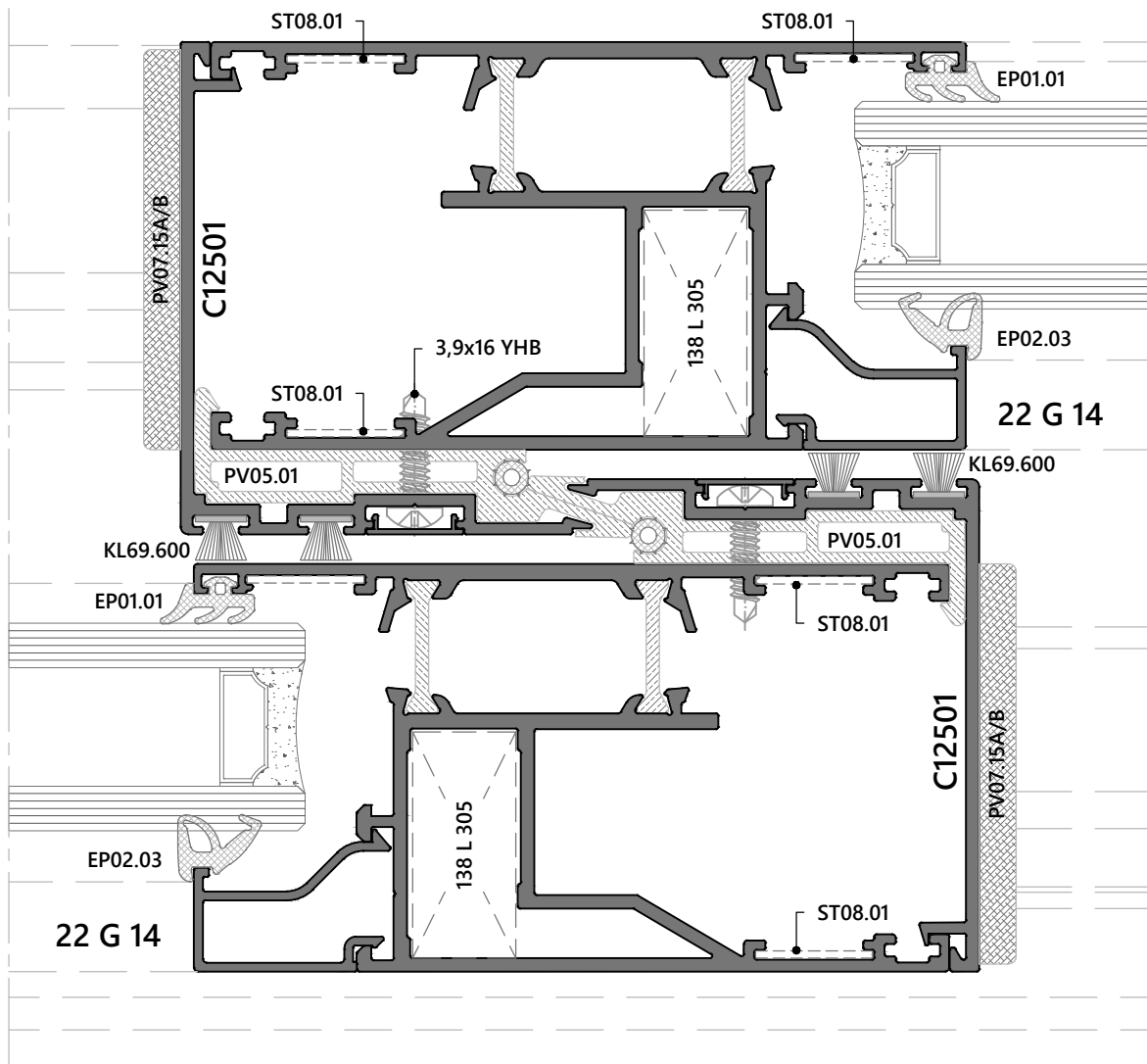

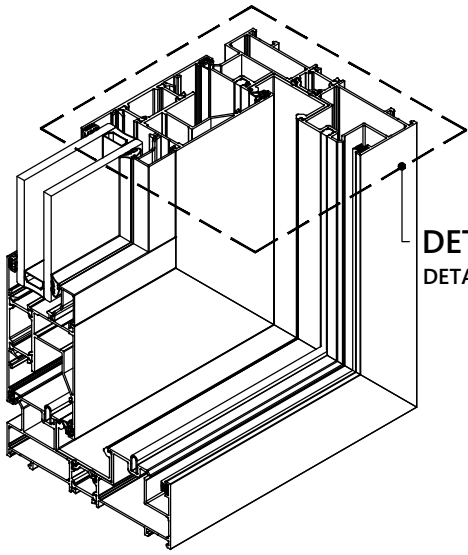

DETAJ - 10
DETAIL - 10

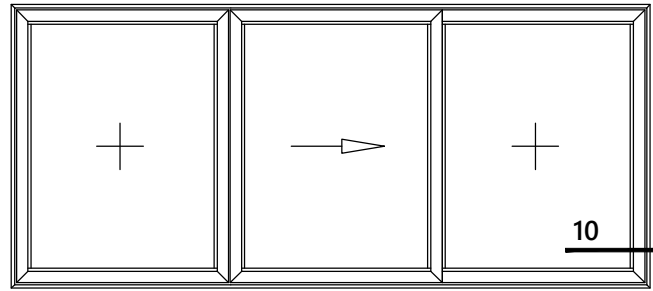

ÖLÇEK : 1/1
Scale : 1/1

DETAJ - 10
DETAIL - 10

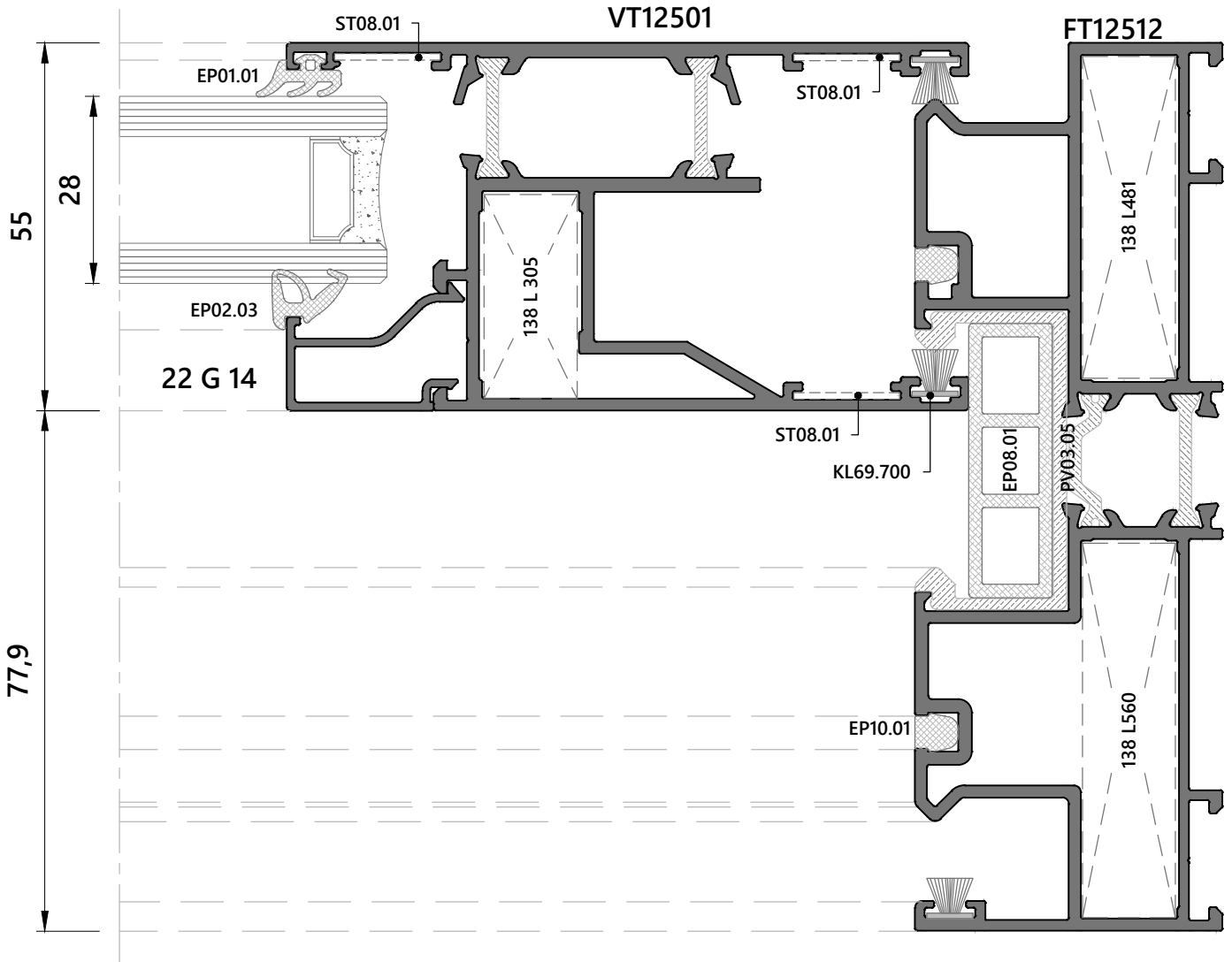

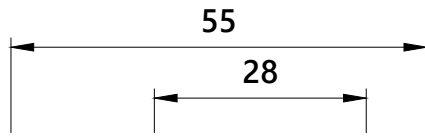
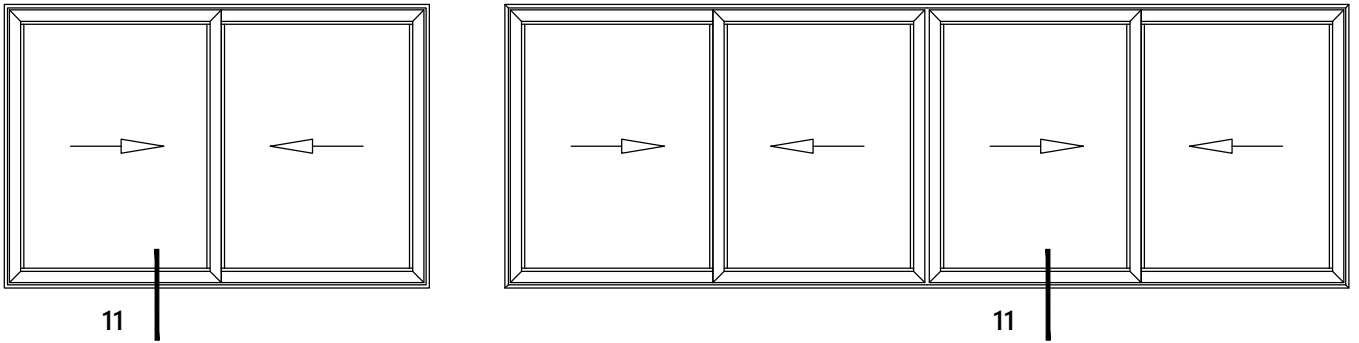

ÖLÇEK : 1/1
Scale : 1/1

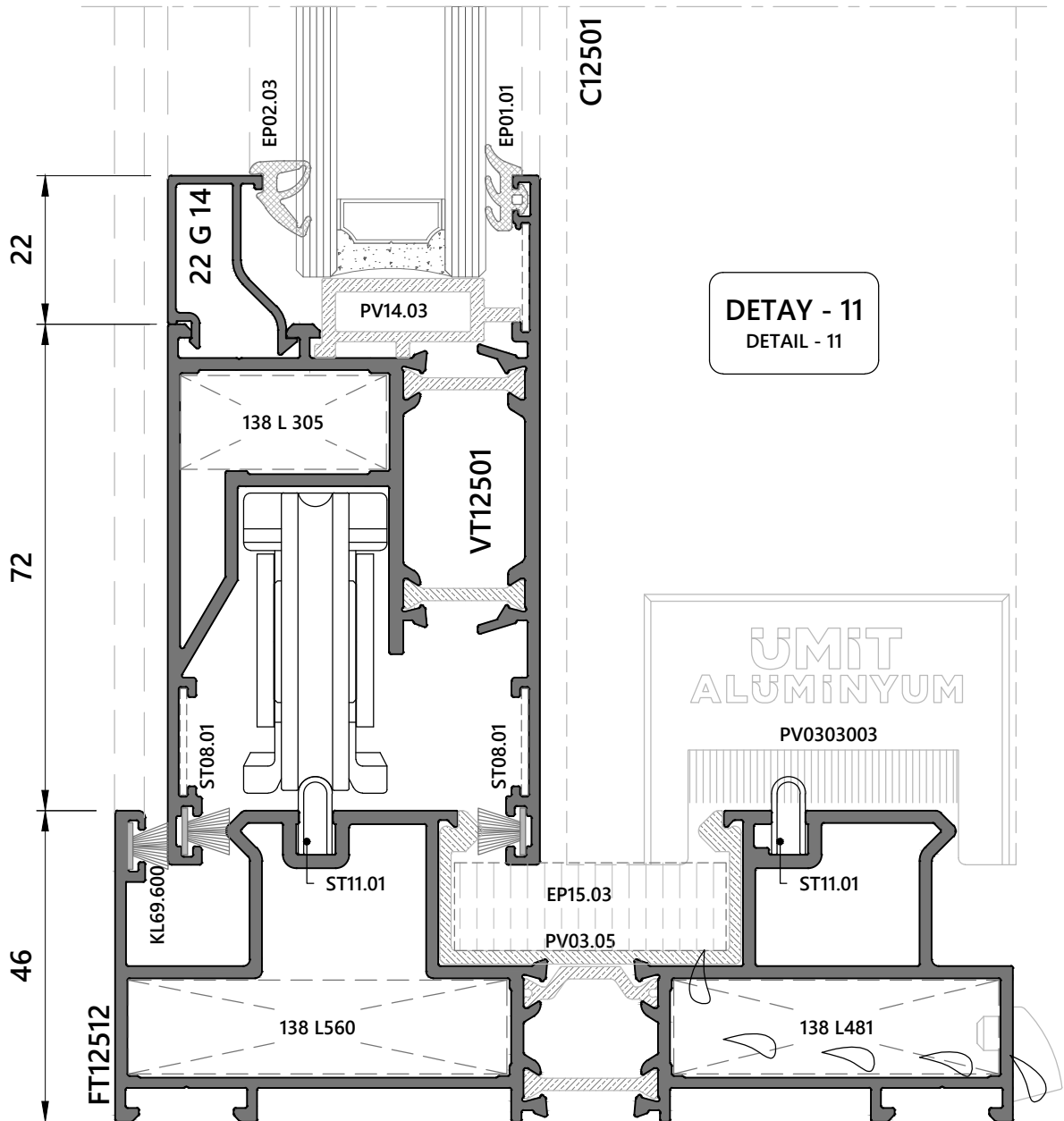

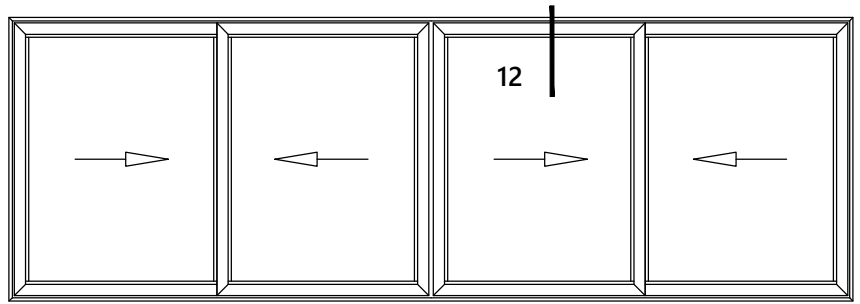
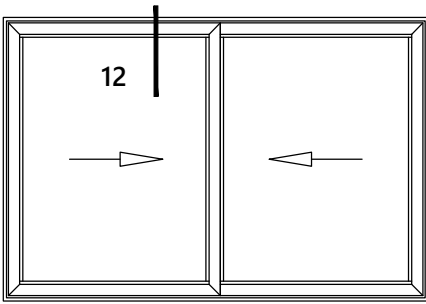

ÖLÇEK : 1/1
Scale : 1/1

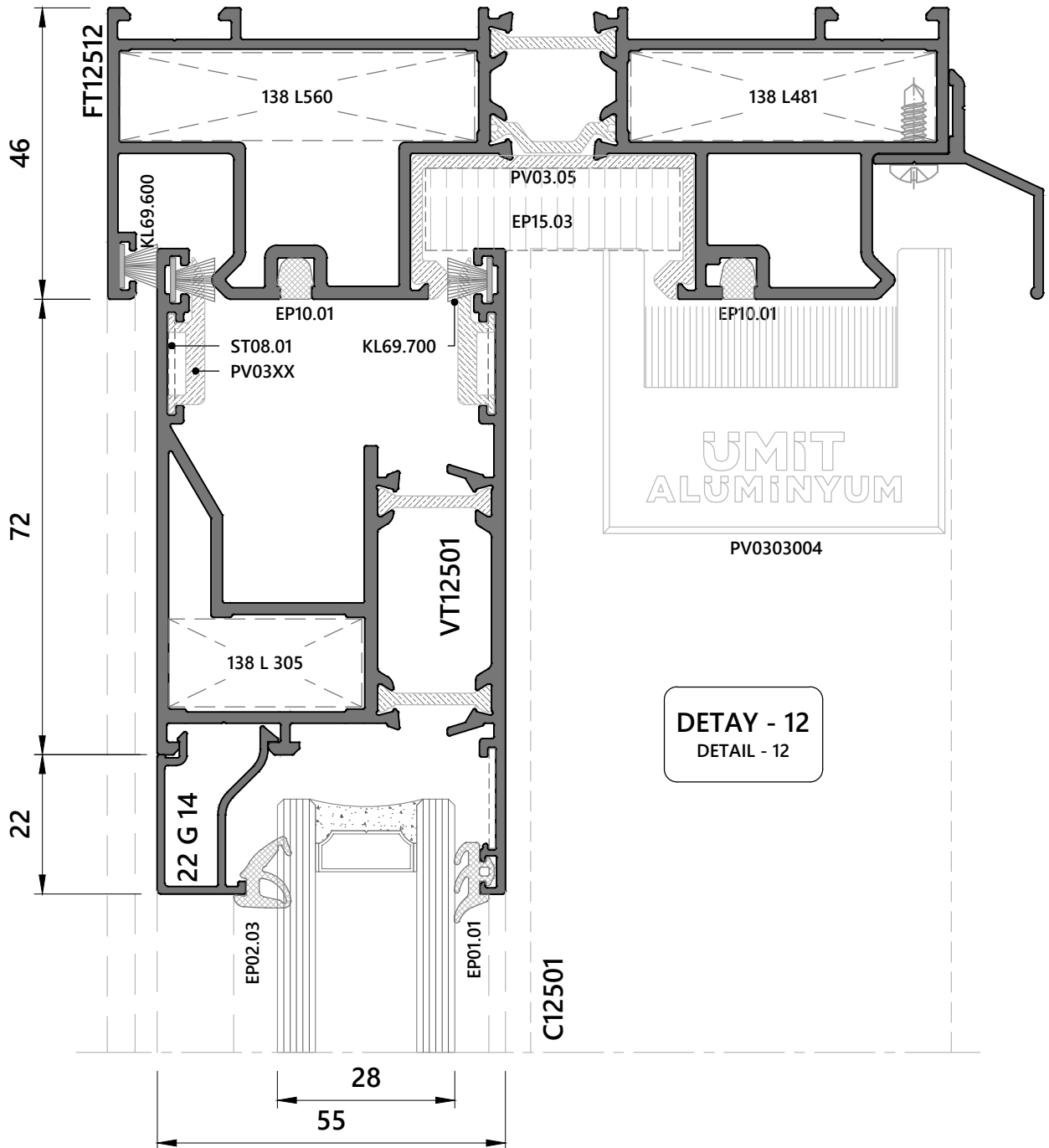

DETAY - 12
DETAIL - 12

DETAY - 12
DETAIL - 12

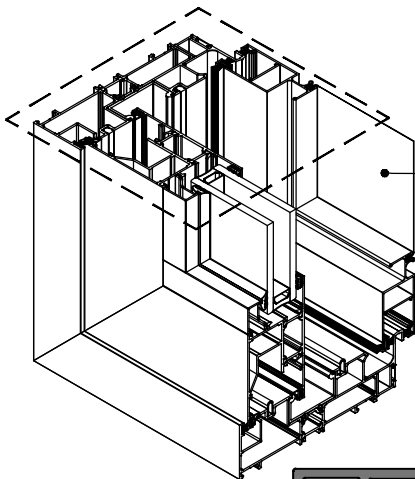

DETAY - 12
DETAIL - 12

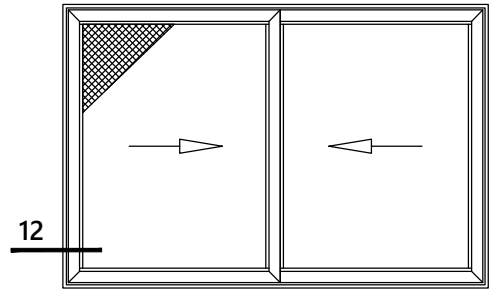

ÖLÇEK : 1/1
Scale : 1/1

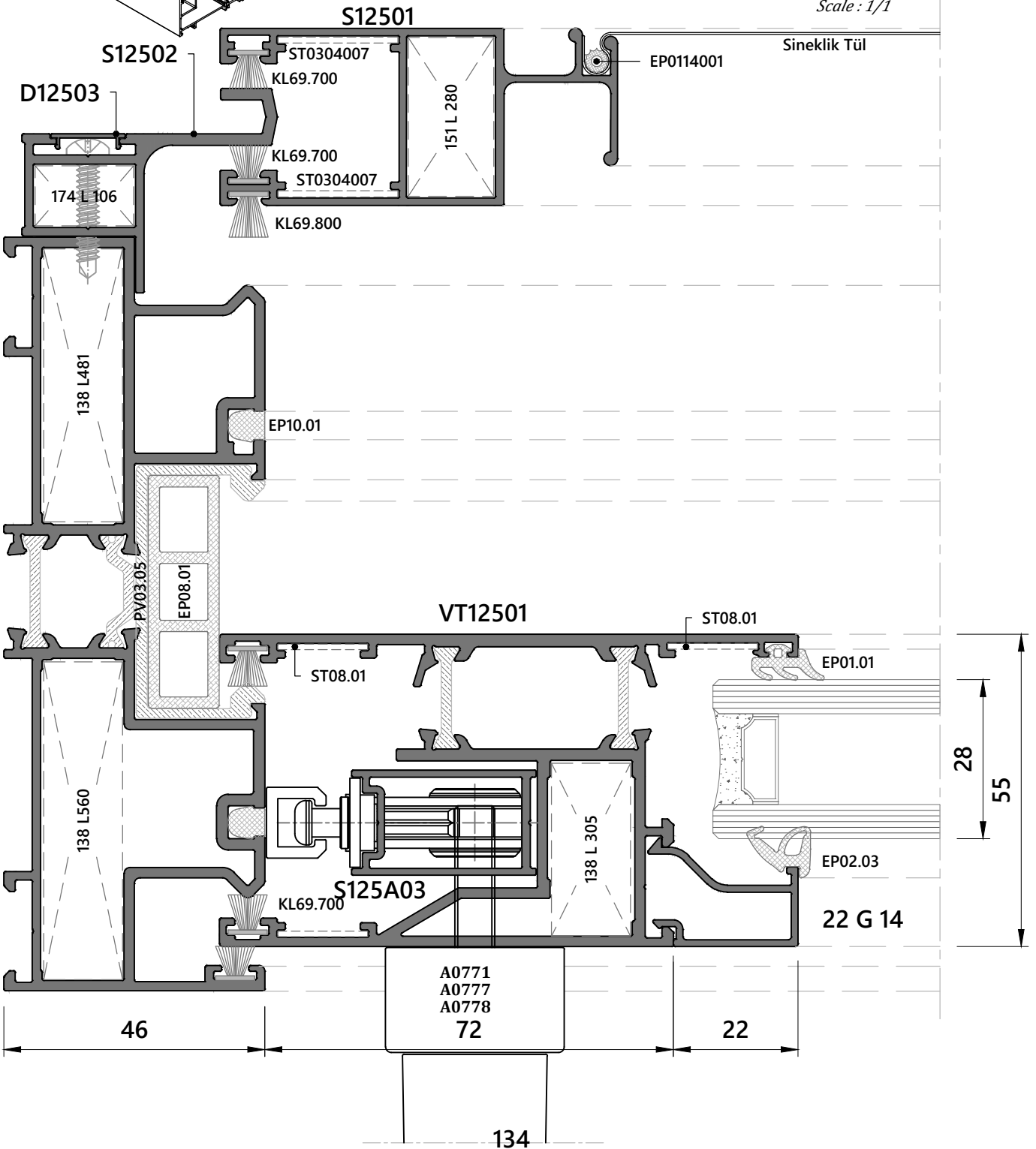

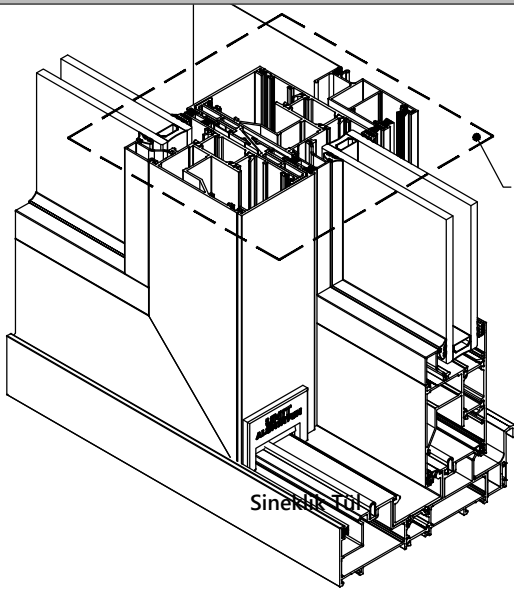

DETAY - 13
DETAIL - 13

DETAY - 13
DETAIL - 13

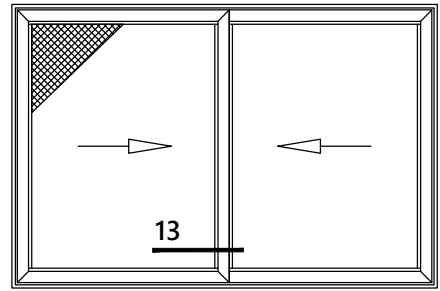

ÖLÇEK : 1/1
Scale : 1/1

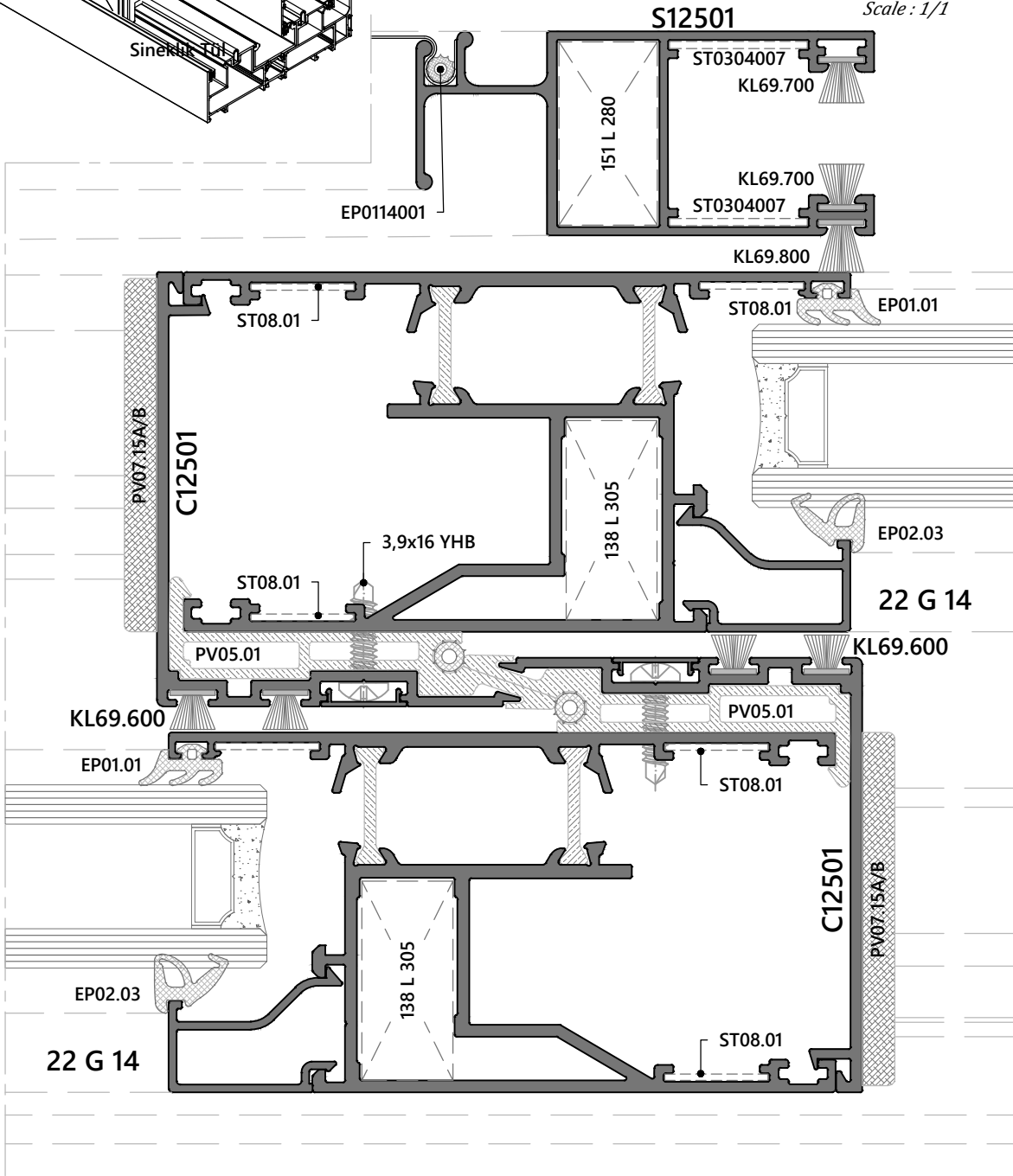

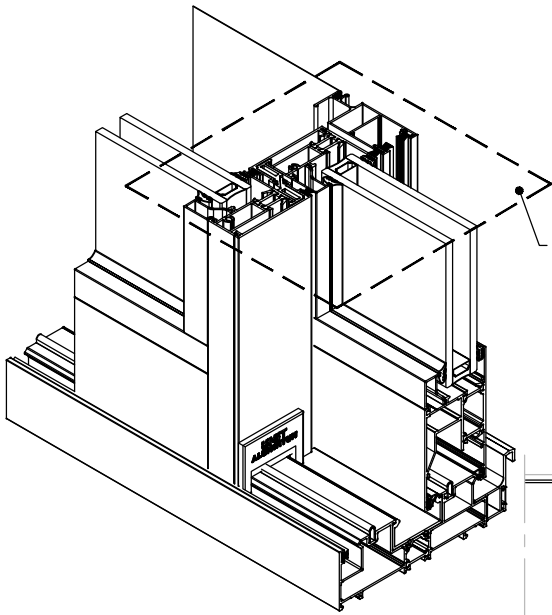

DETAY - 13a
DETAIL - 13a

DETAY - 13a
DETAIL - 13a

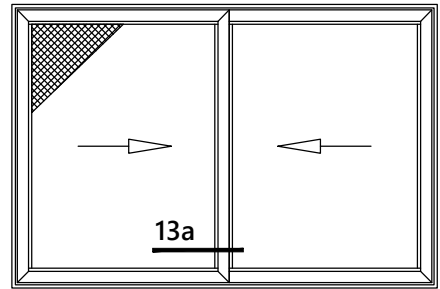

ÖLÇEK : 1/1
Scale : 1/1

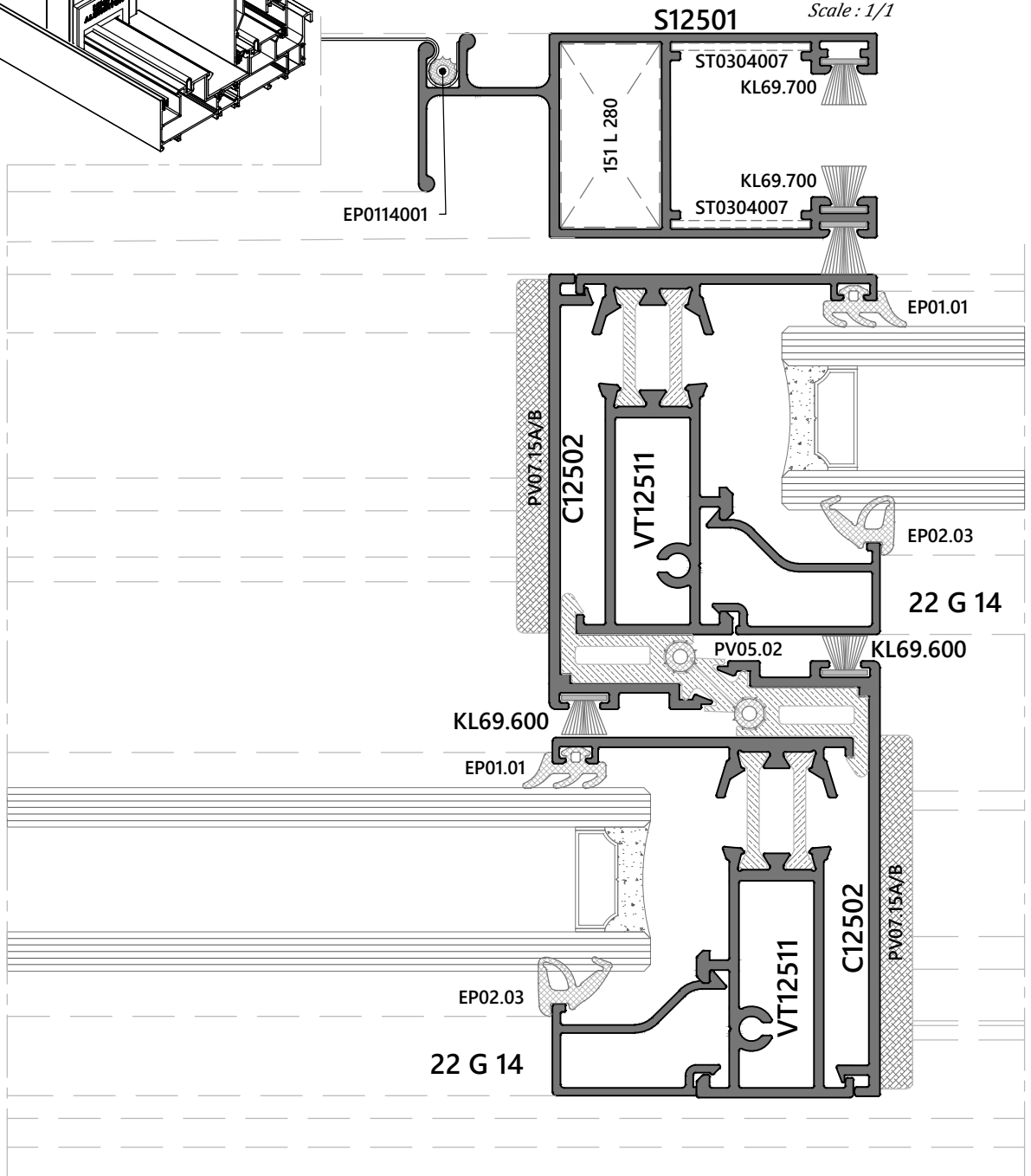

DETAY - 14
DETAIL - 14

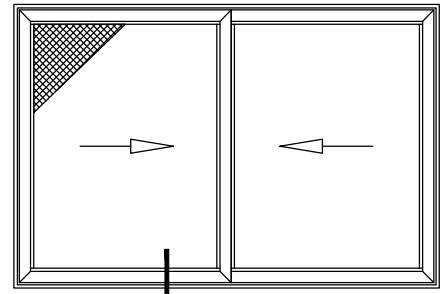
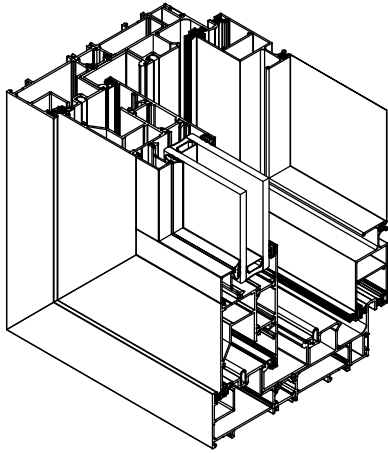

14

ÖLÇEK : 1/1
Scale : 1/1

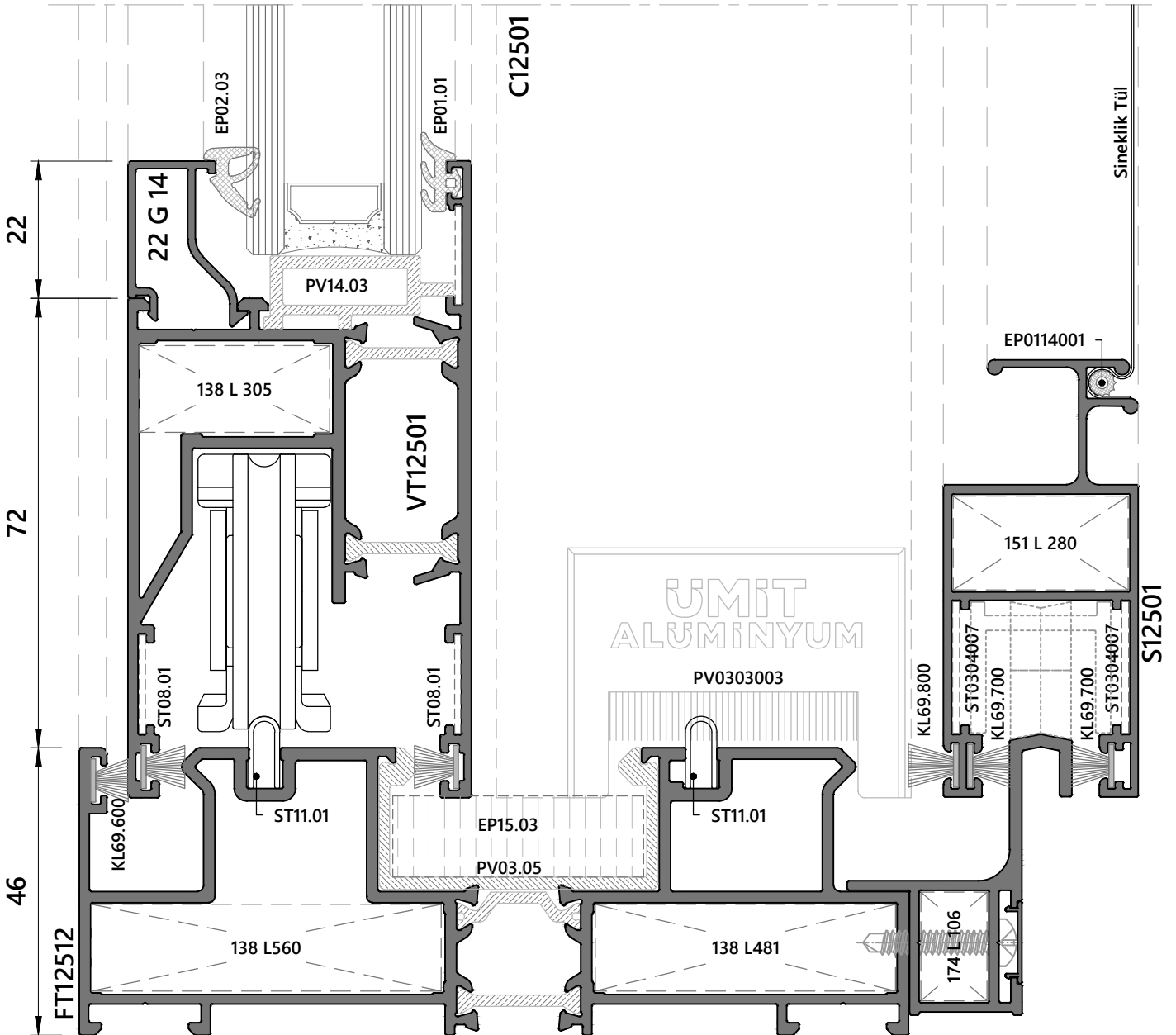
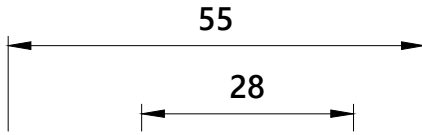

DETAY - 15
DETAY - 15

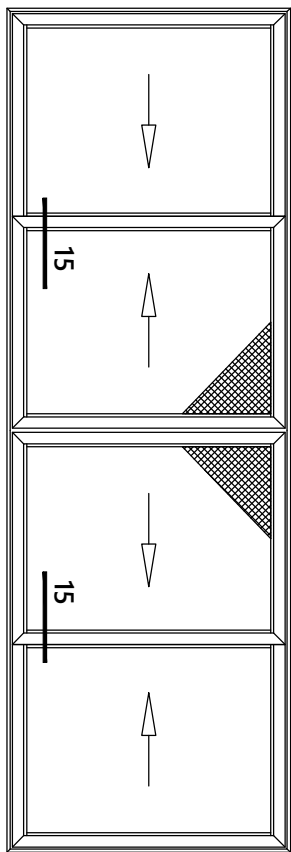

ÖLÇEK : 1/1
Scale : 1/1

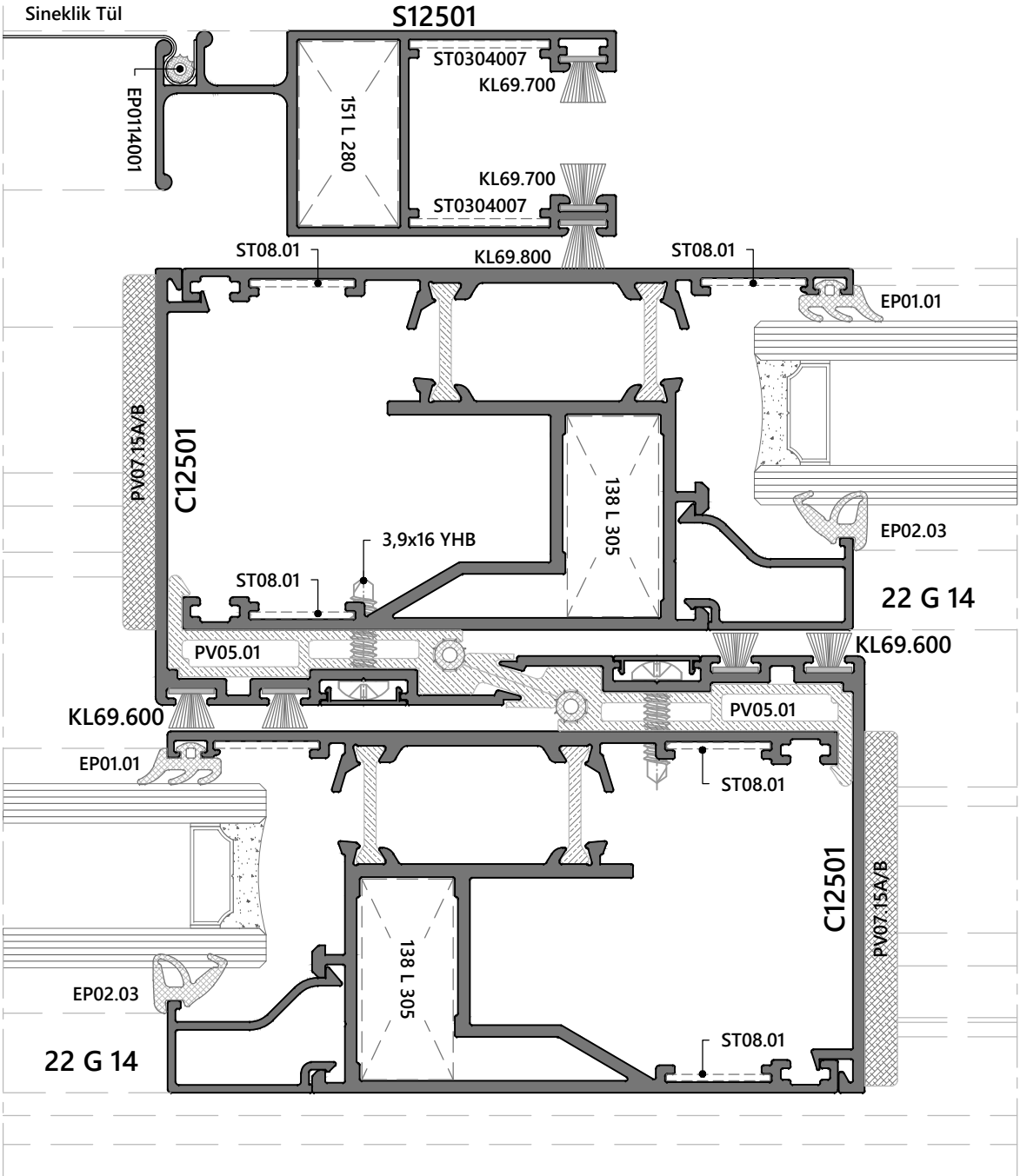

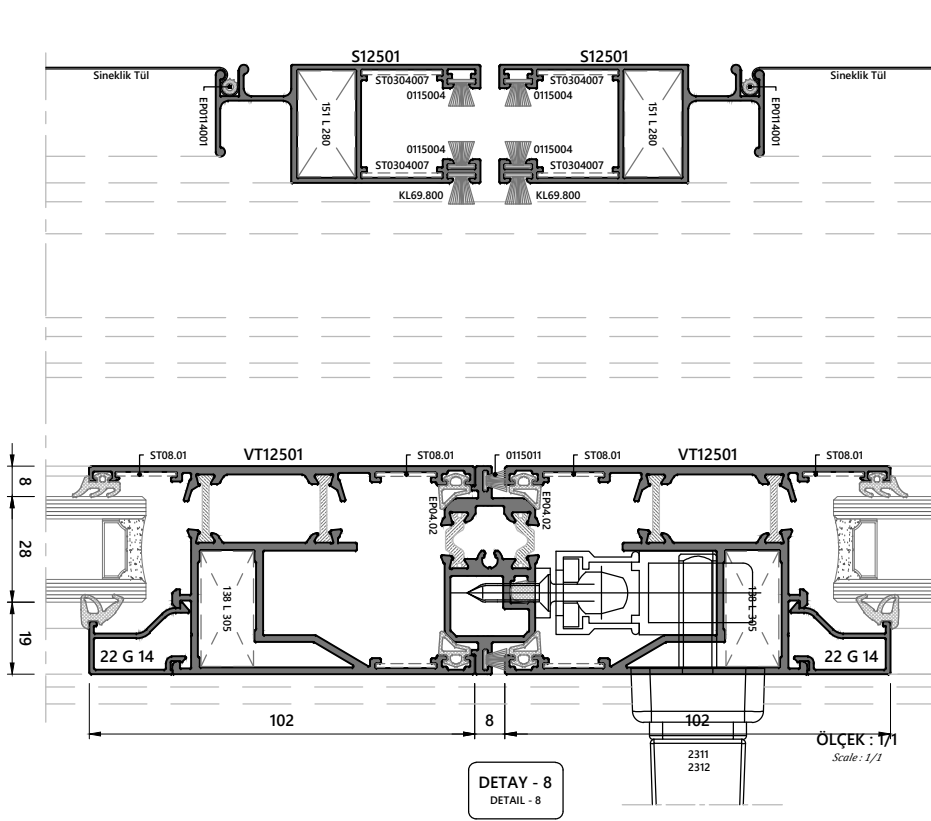
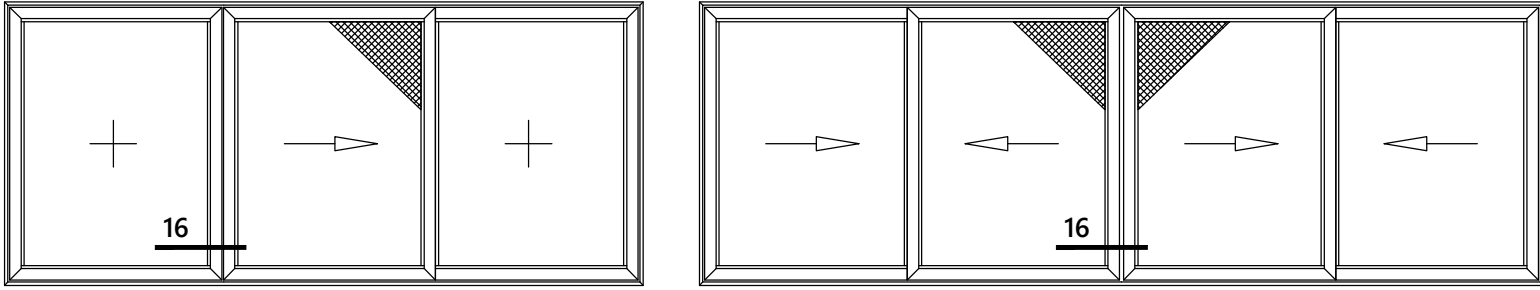

DETAY - 15
DETAIL - 15

ÖLÇEK : 1/2
Scale : 1/2

DETAY - 8
DETAIL - 8

ÖLÇEK : 1/1
Scale : 1/1

ÜÇ RAYLI KASA UYGULAMA DETAYLARI
APPLICATION DETAILS for TRIPLE RAIL FRAME

KALDIRSÜR AÇILIM TİPLERİ

LIFT&SLIDE TYPES OF OPENING

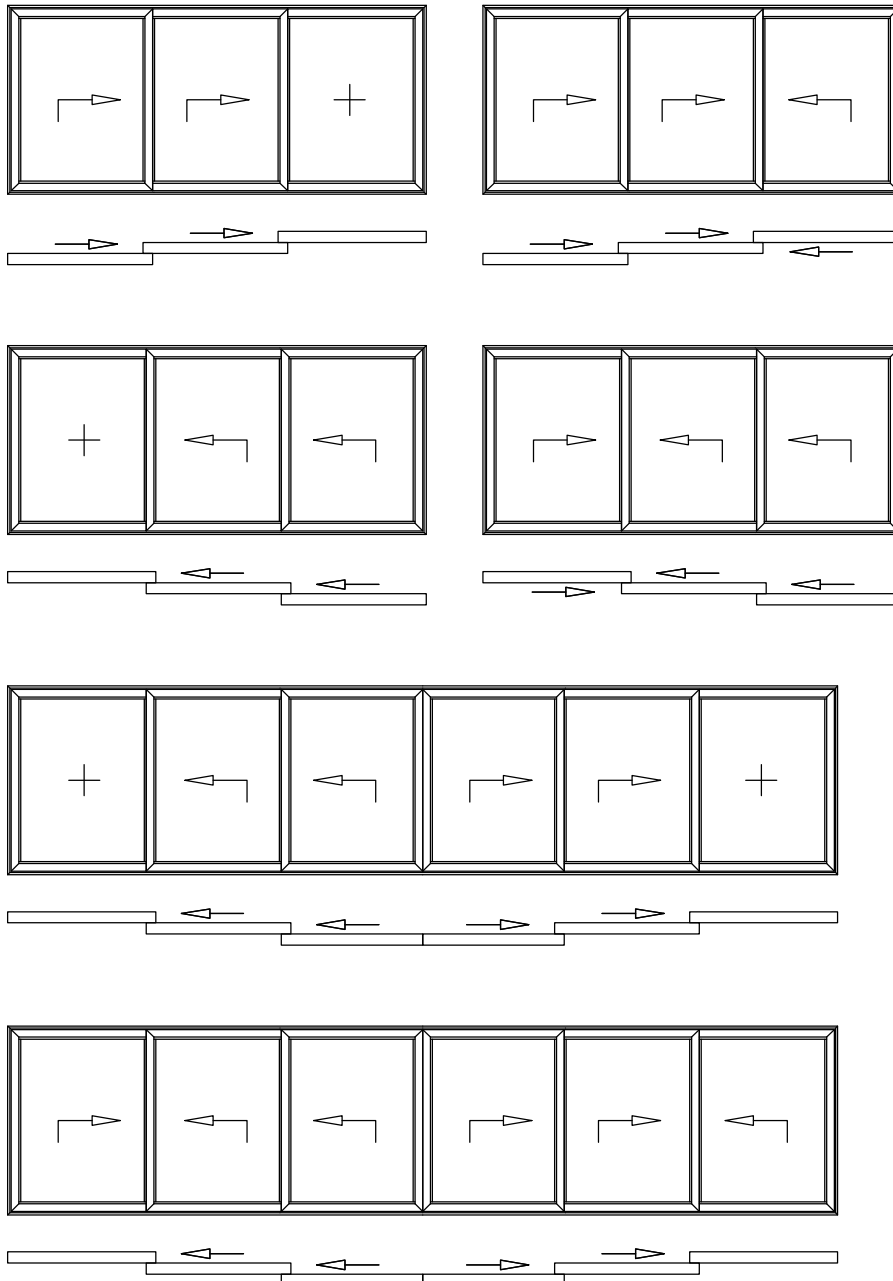

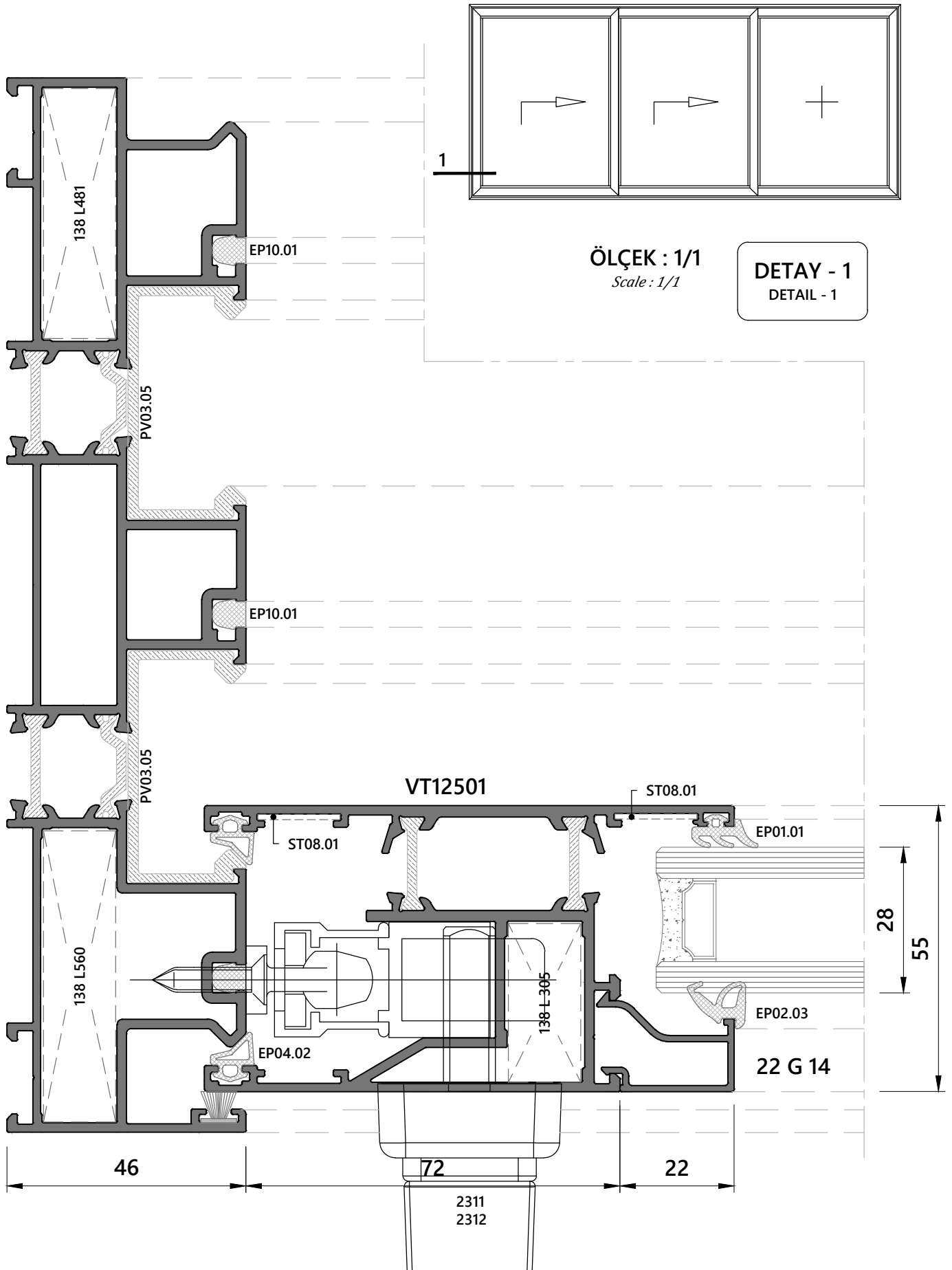

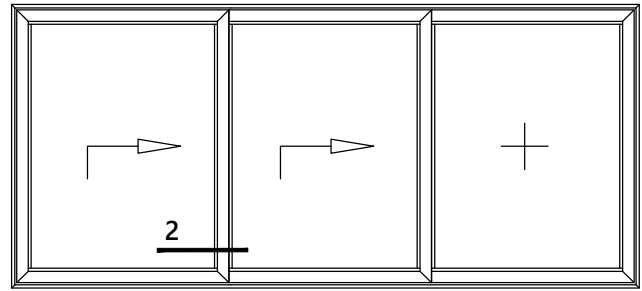

ÖLÇEK : 1/1
Scale : 1/1

DETAY - 2
DETAIL - 2

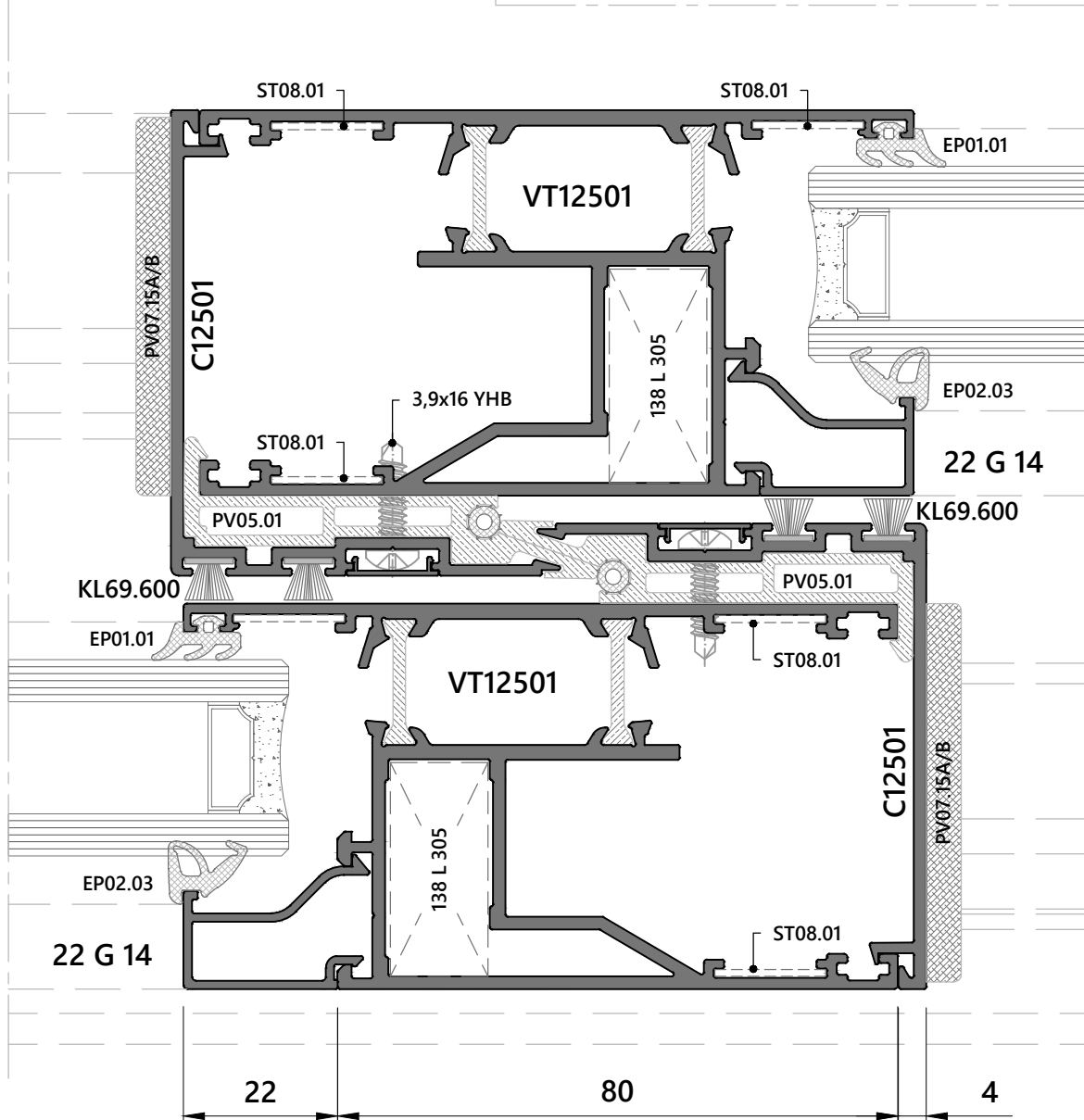

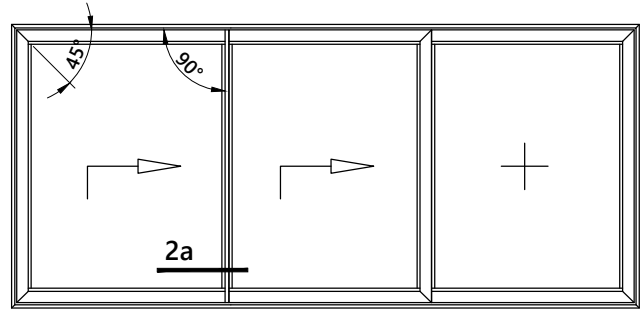

ÖLÇEK : 1/1
Scale : 1/1

DETAY - 2a
DETAIL - 2a

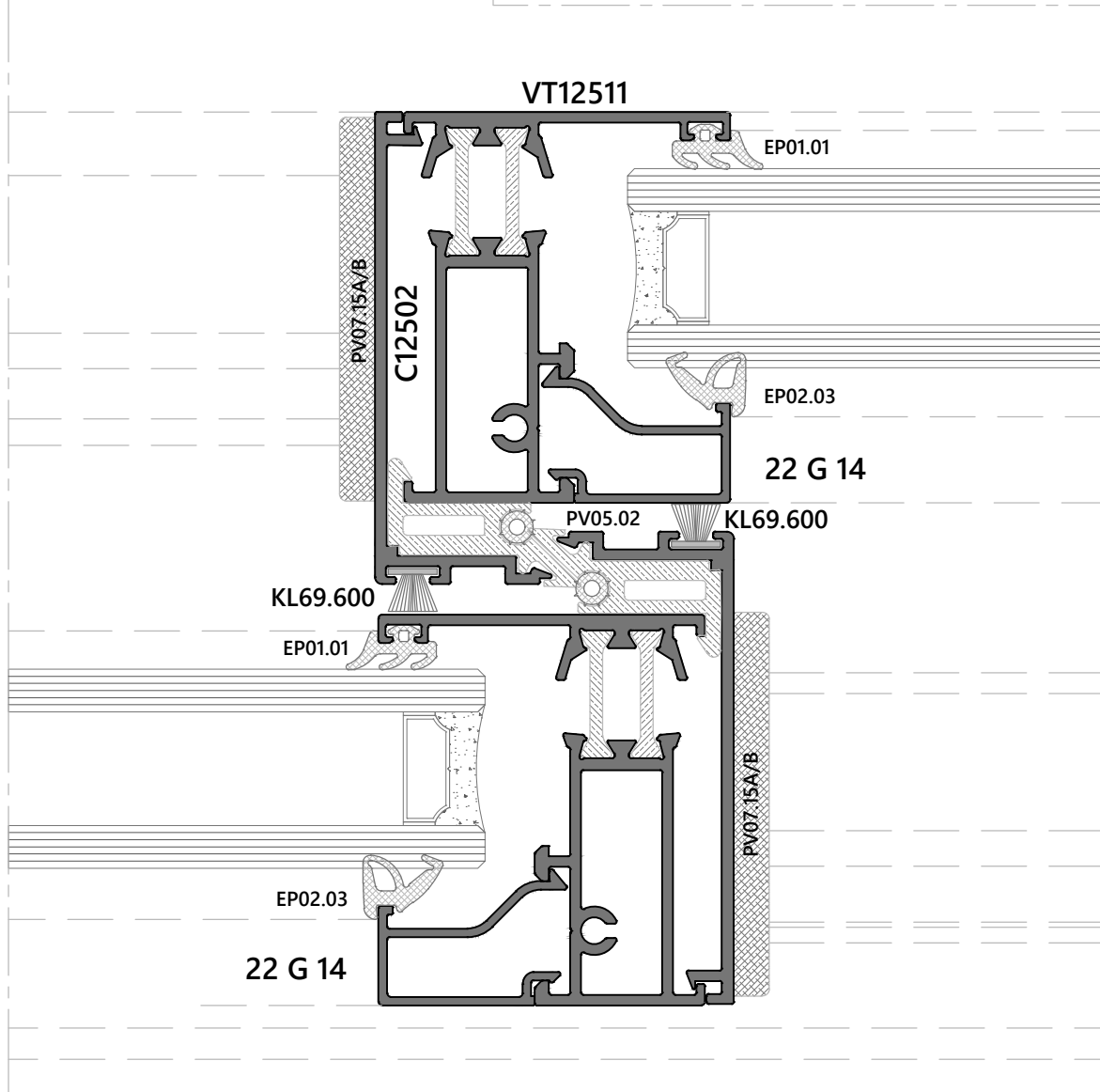

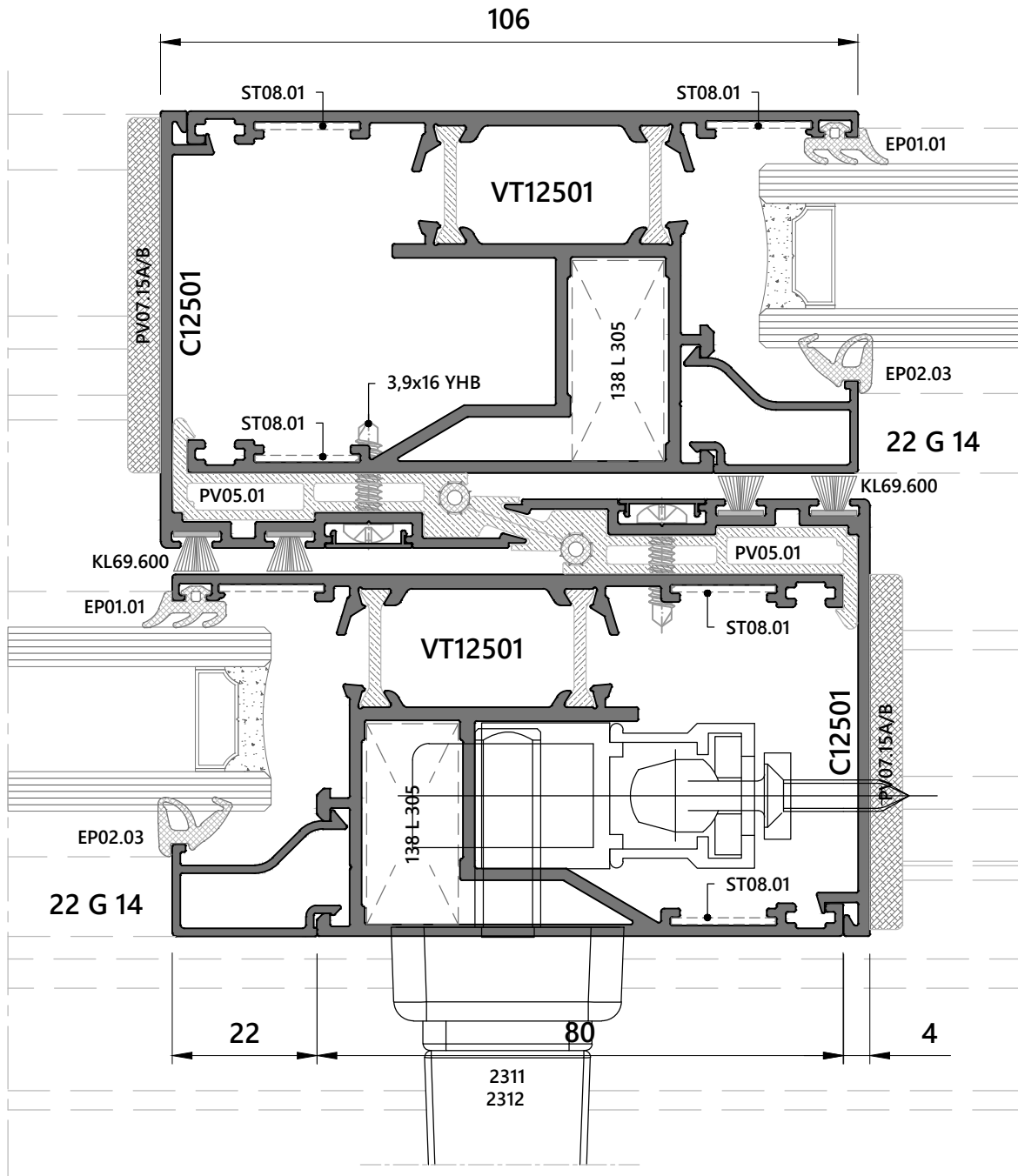

ÖLÇEK : 1/1
Scale : 1/1

DETAY - 3
DETAIL - 3

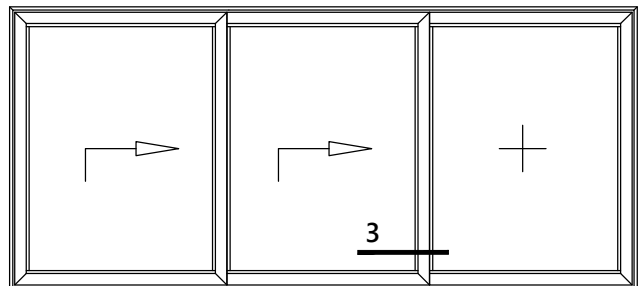

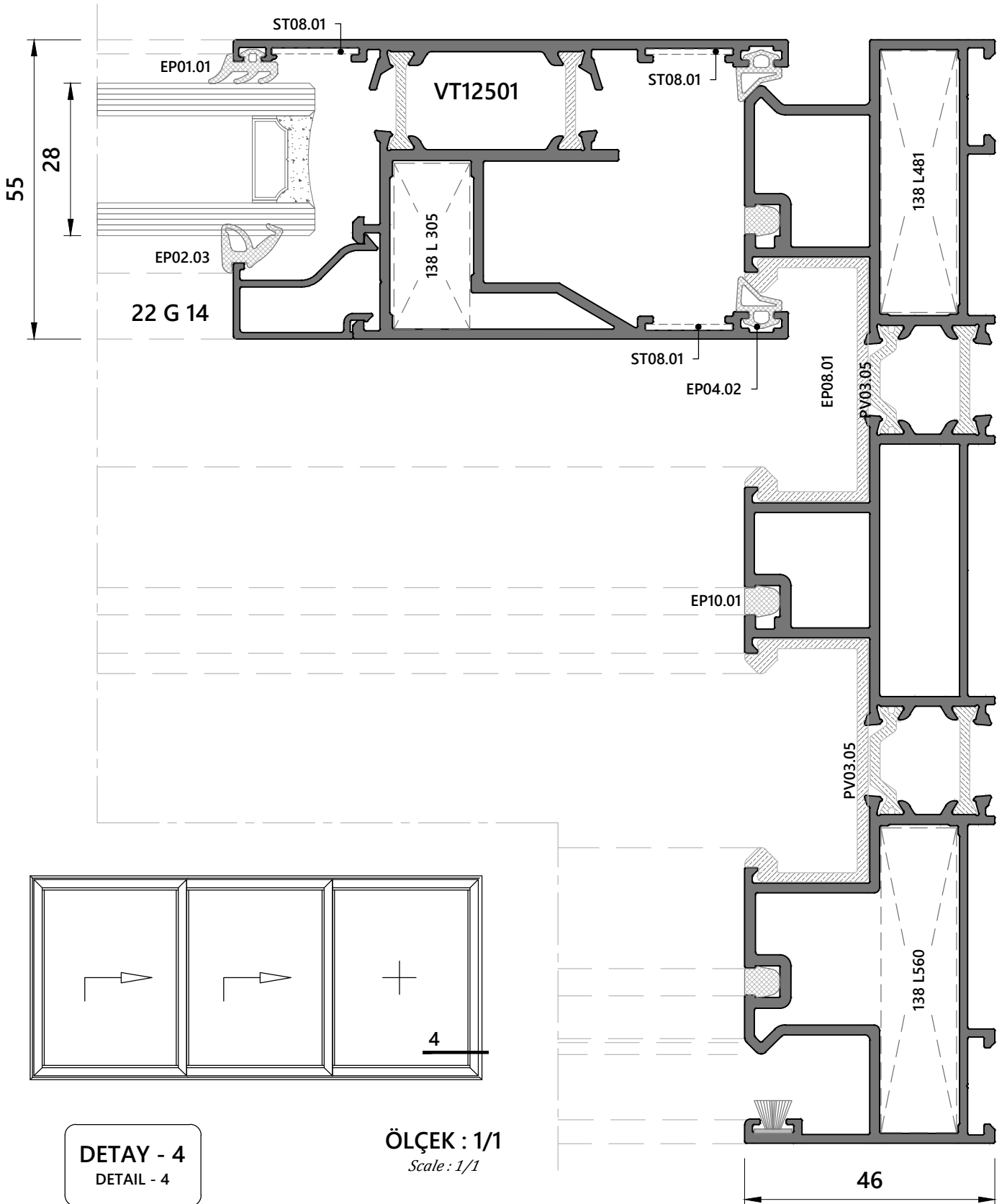

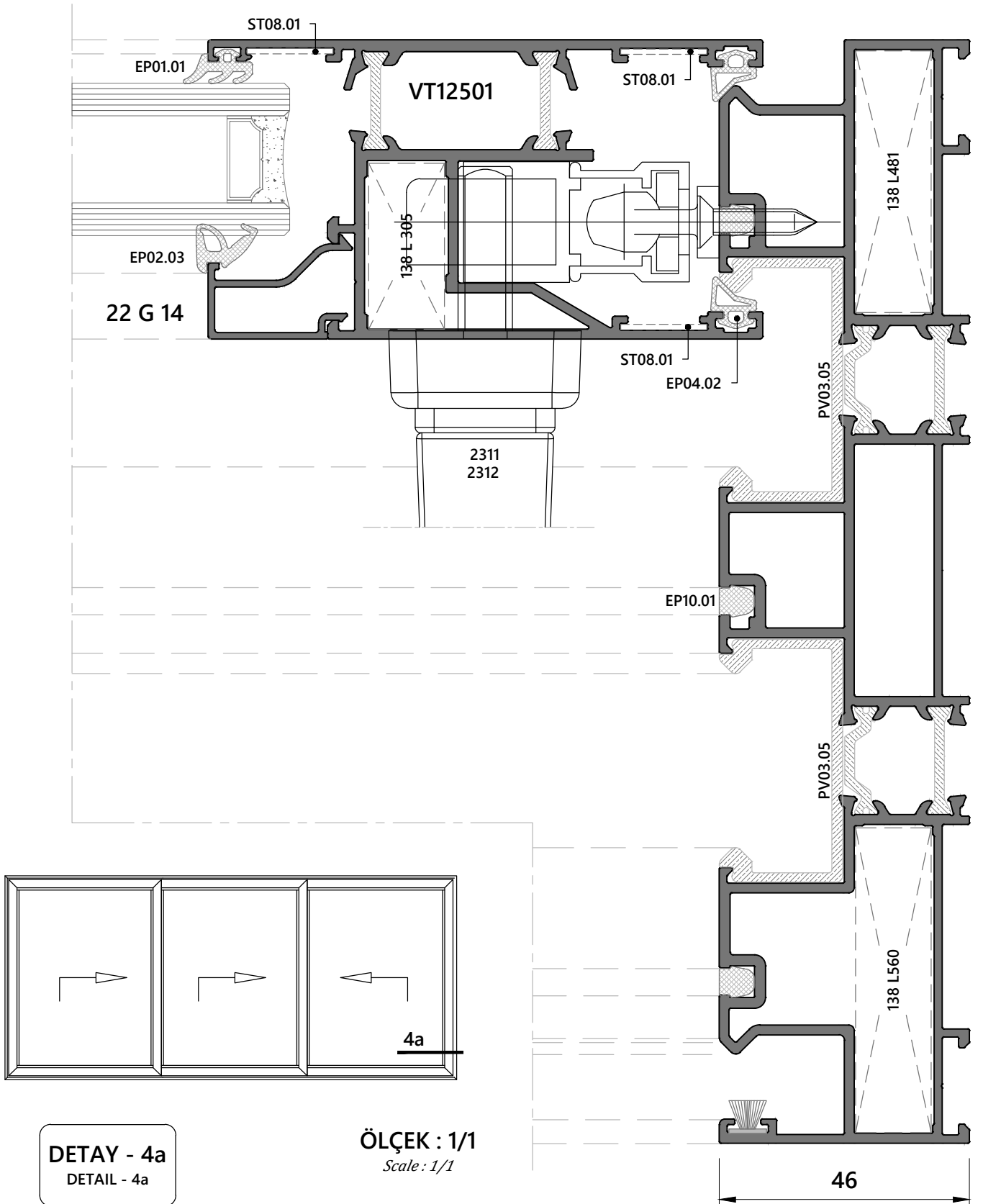

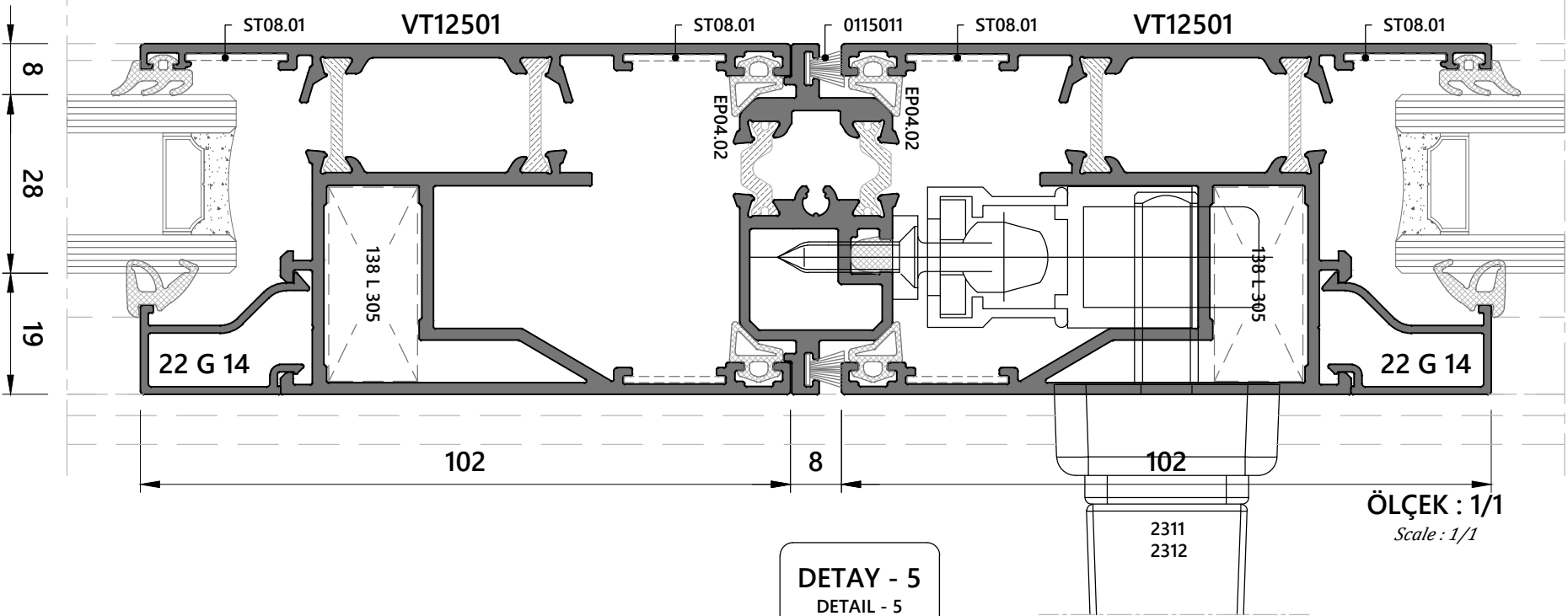
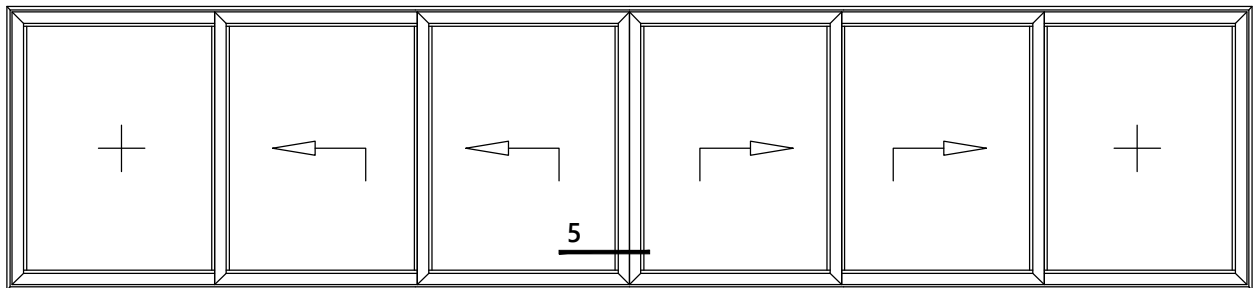

DETAY - 5
DETAIL - 5

ÖLÇEK : 1/1
Scale : 1/1

148

8

28

19

102

8

102

2311
2312

22 G 14

138 L 305

138 L 305

ST08.01

VT12501

ST08.01

011501

ST08.01

VT12501

ST08.01

EP04.02

EP04.02

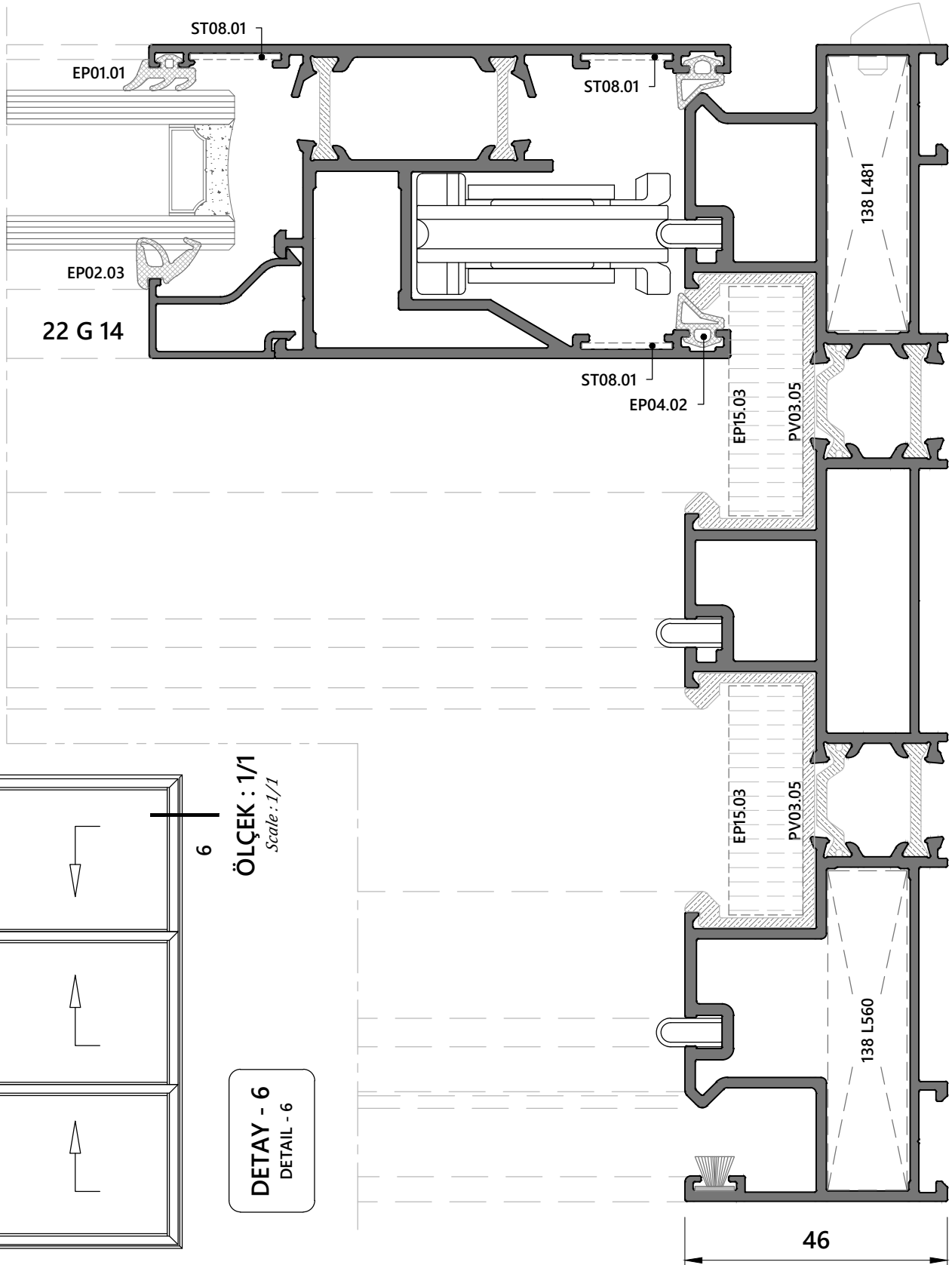

KLASİK SÜRME AÇILIM TİPLERİ

SLIDING TYPES OF OPENING

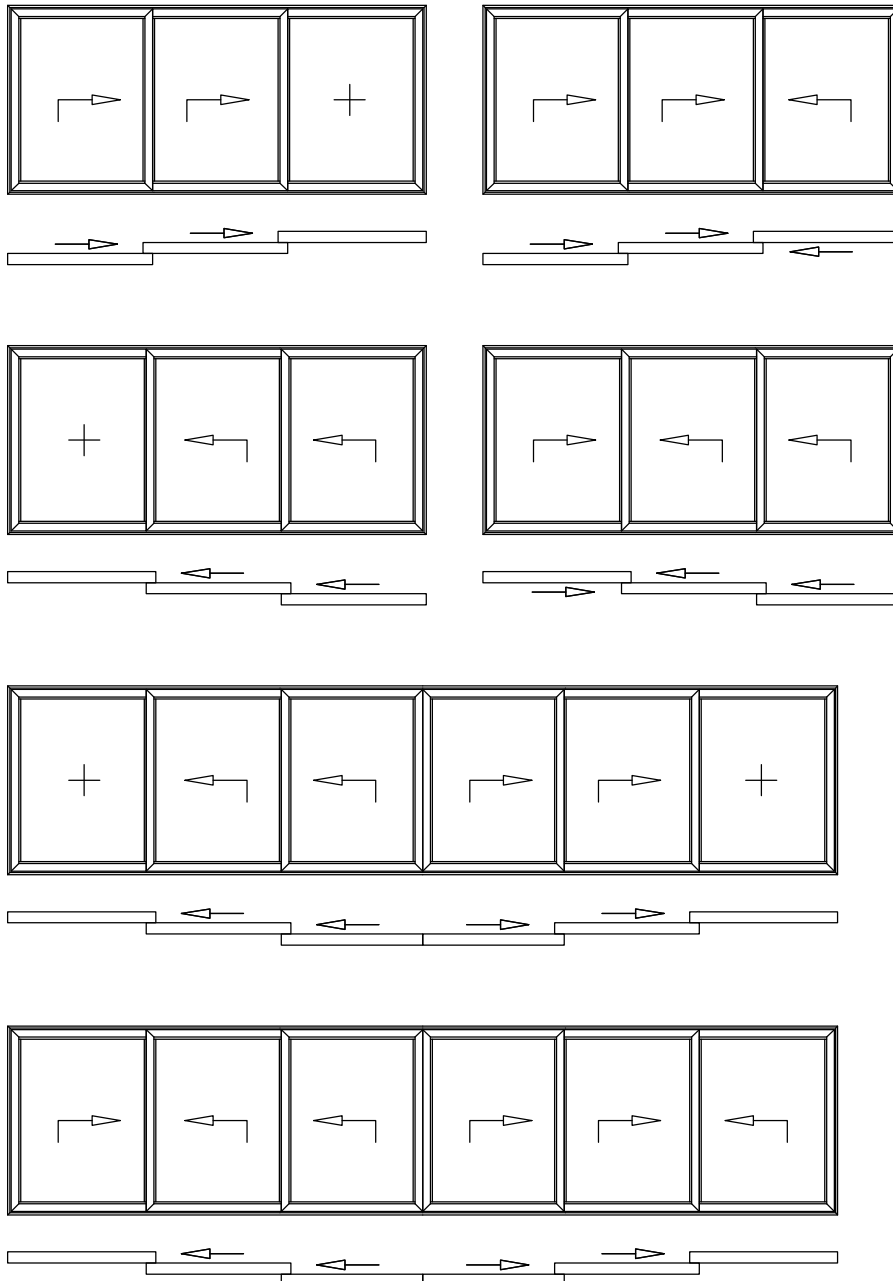

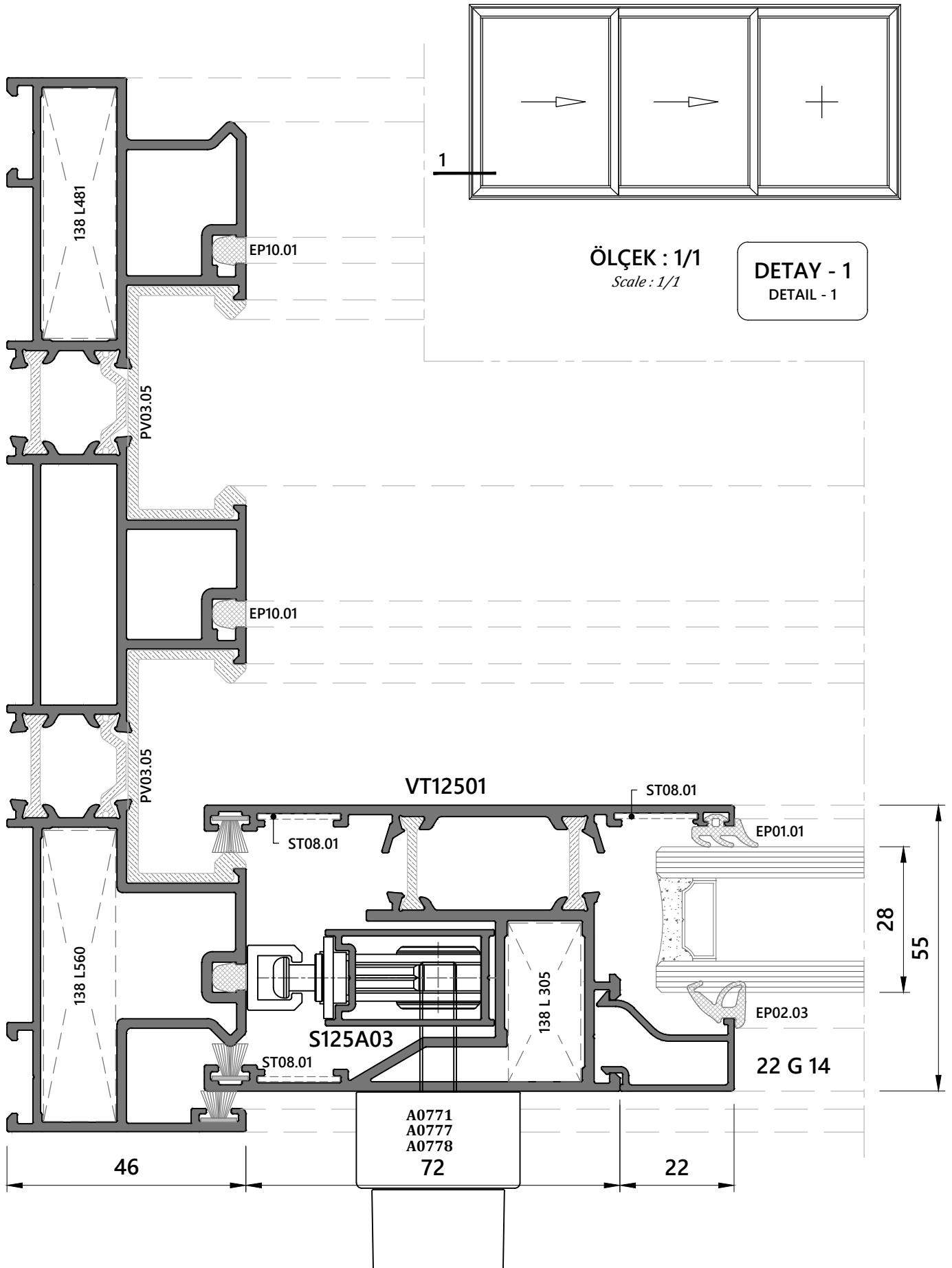

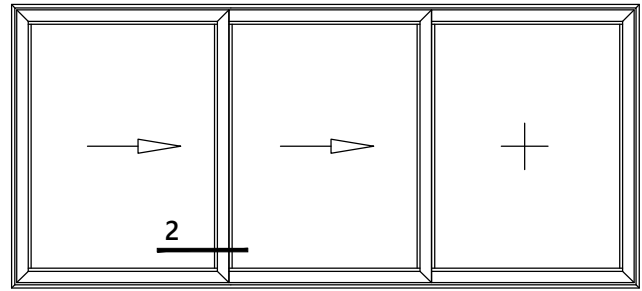

ÖLÇEK : 1/1
Scale : 1/1

DETAY - 2
DETAIL - 2

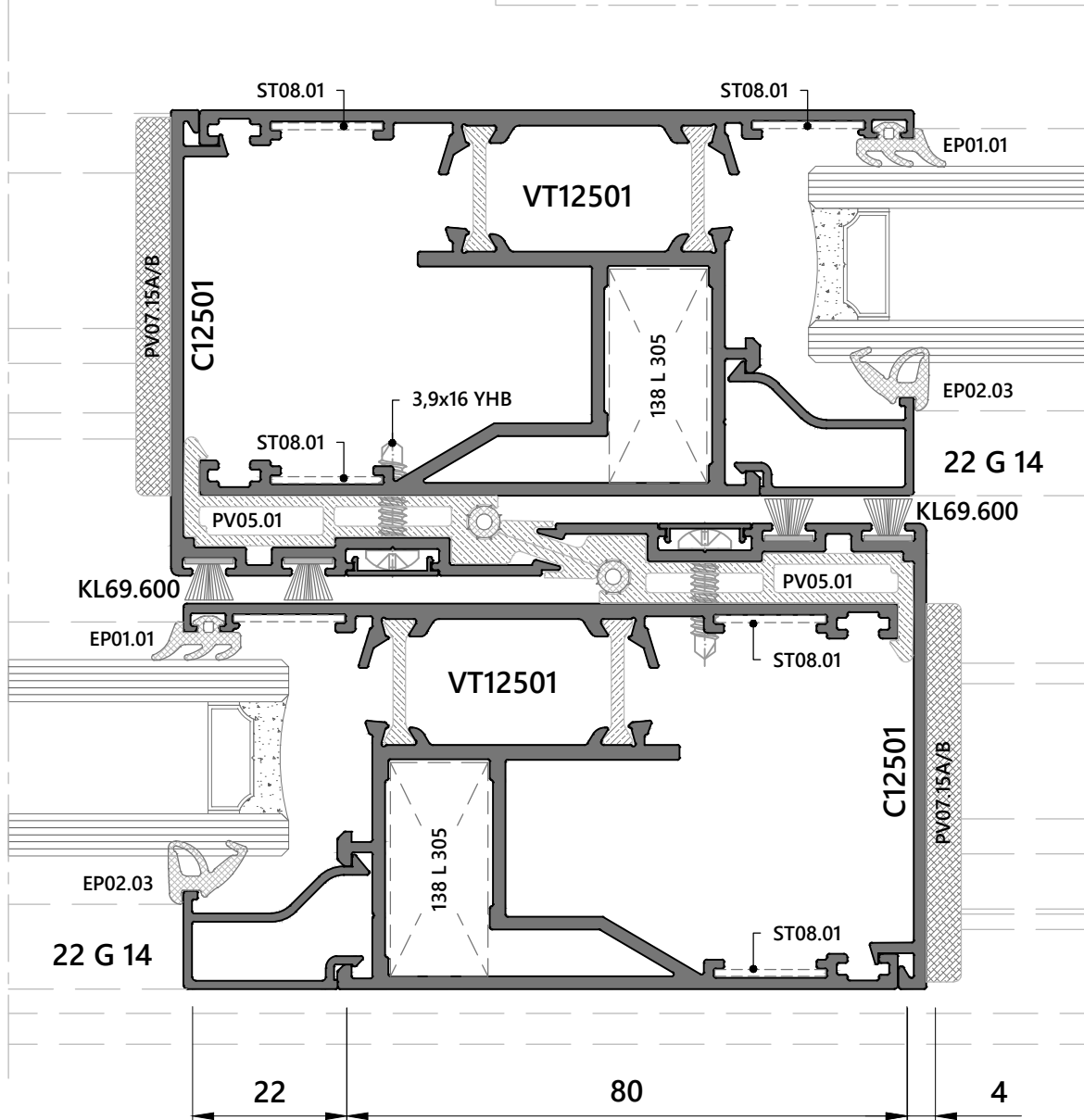

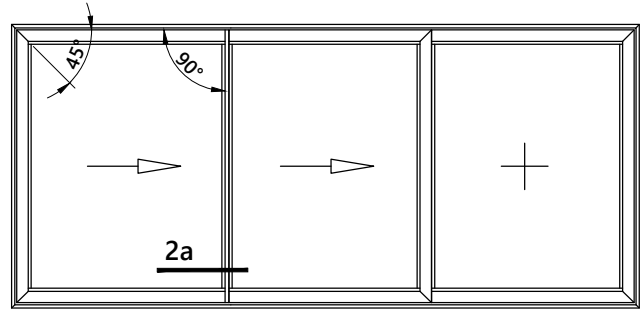

ÖLÇEK : 1/1
Scale : 1/1

DETAY - 2a
DETAIL - 2a

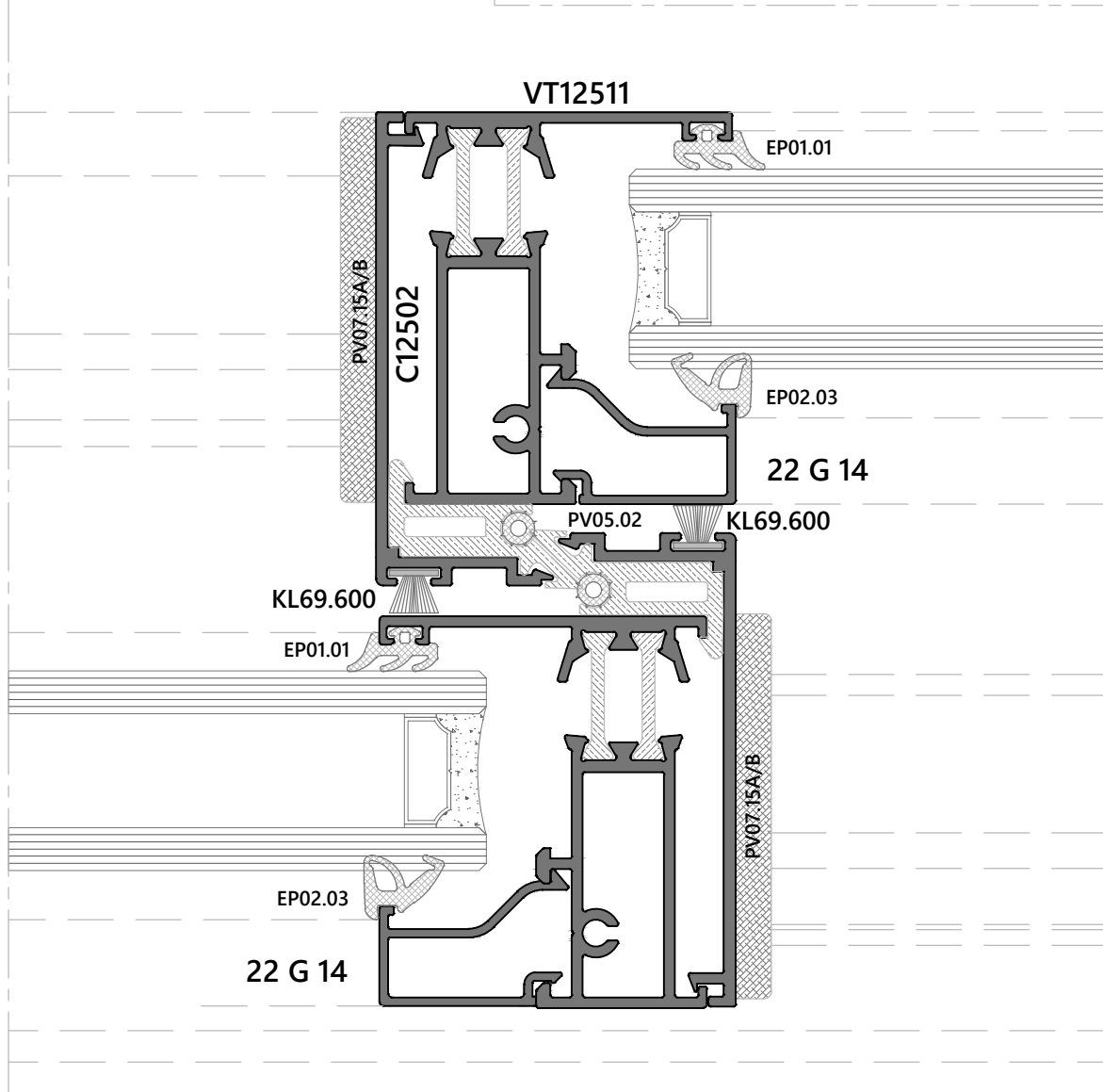

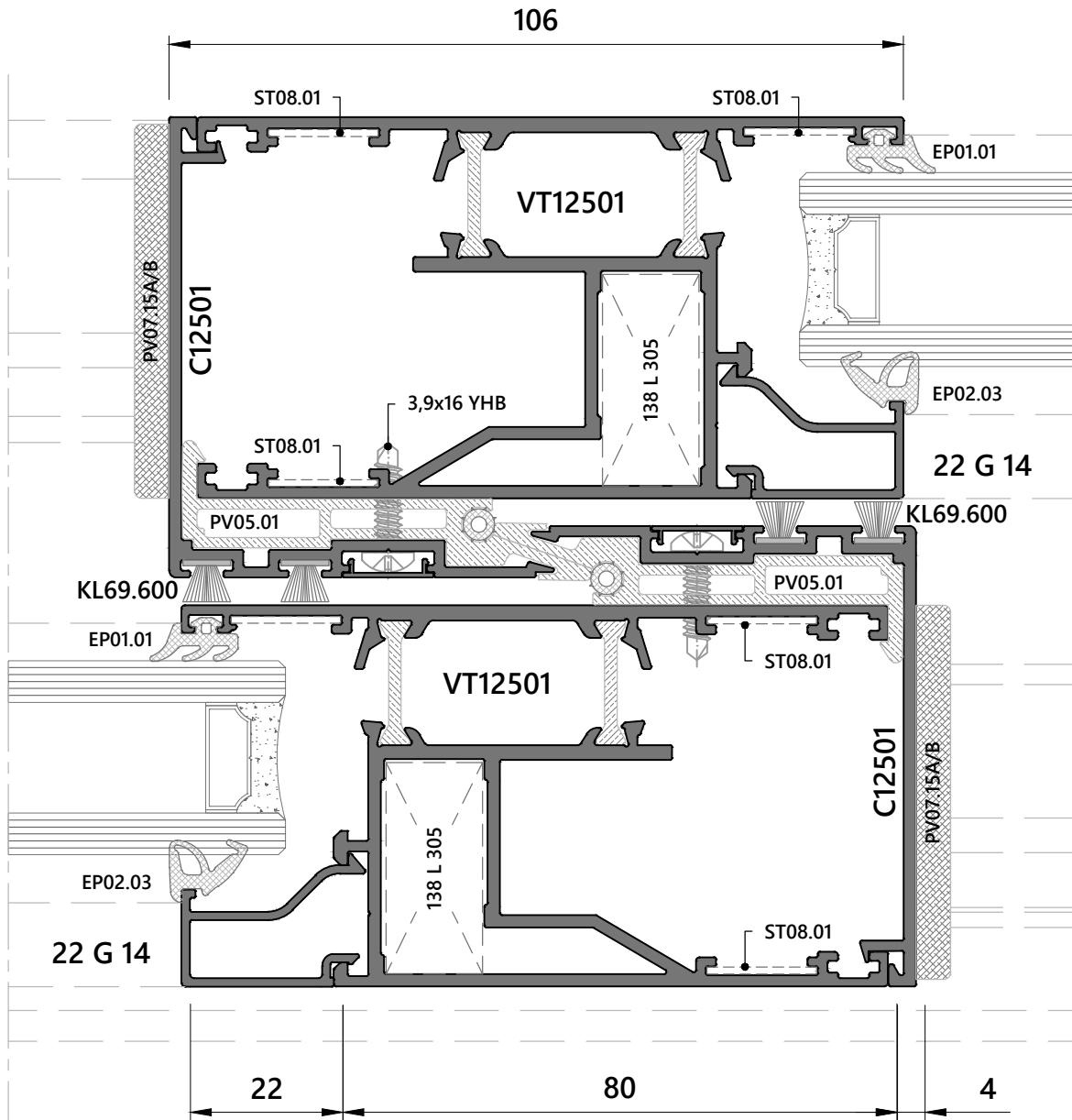

ÖLÇEK : 1/1
Scale : 1/1

DETAY - 3
DETAIL - 3

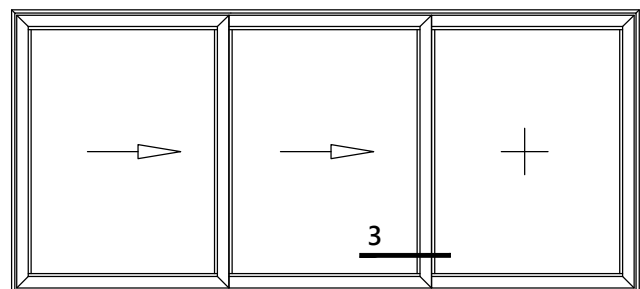

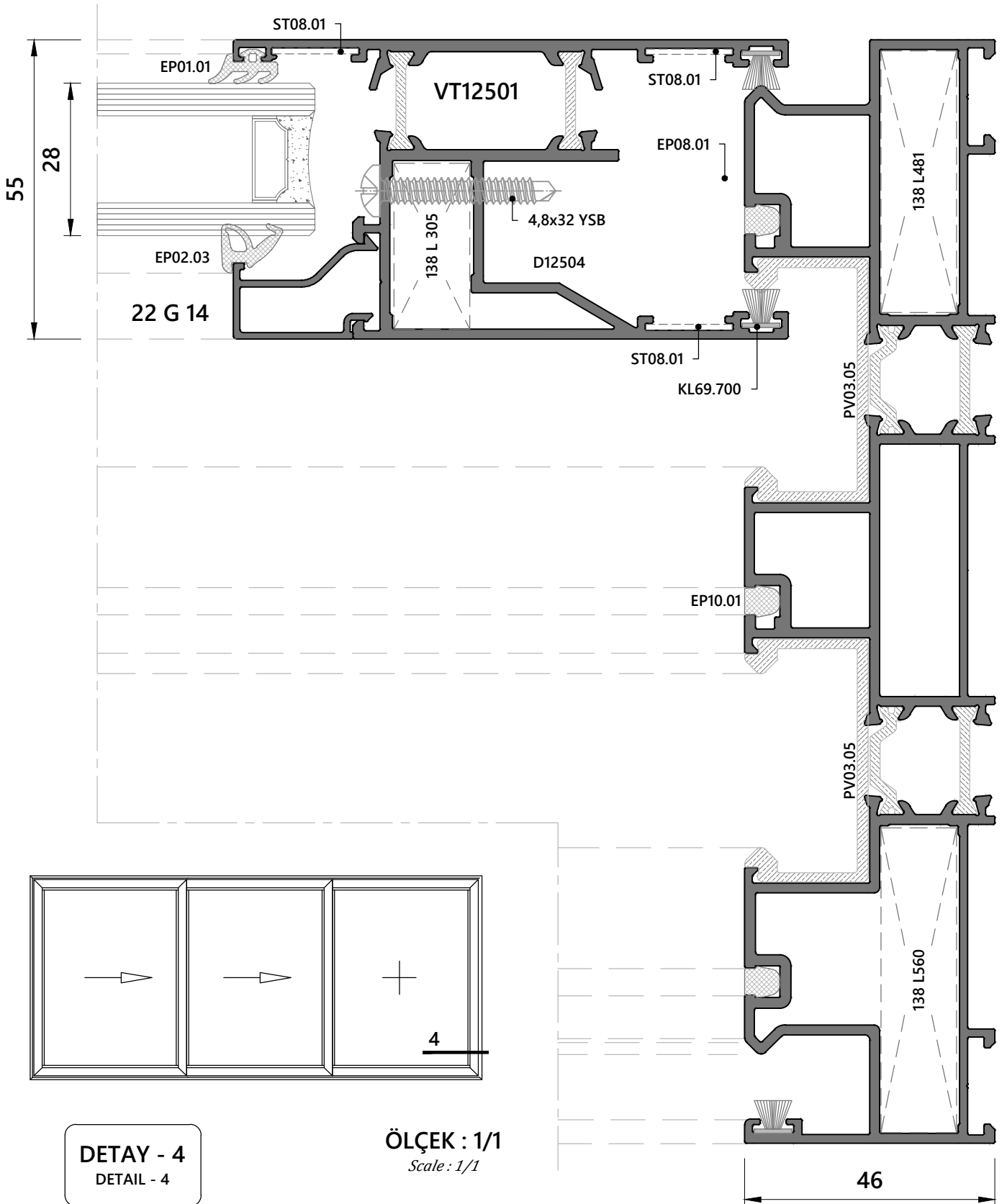

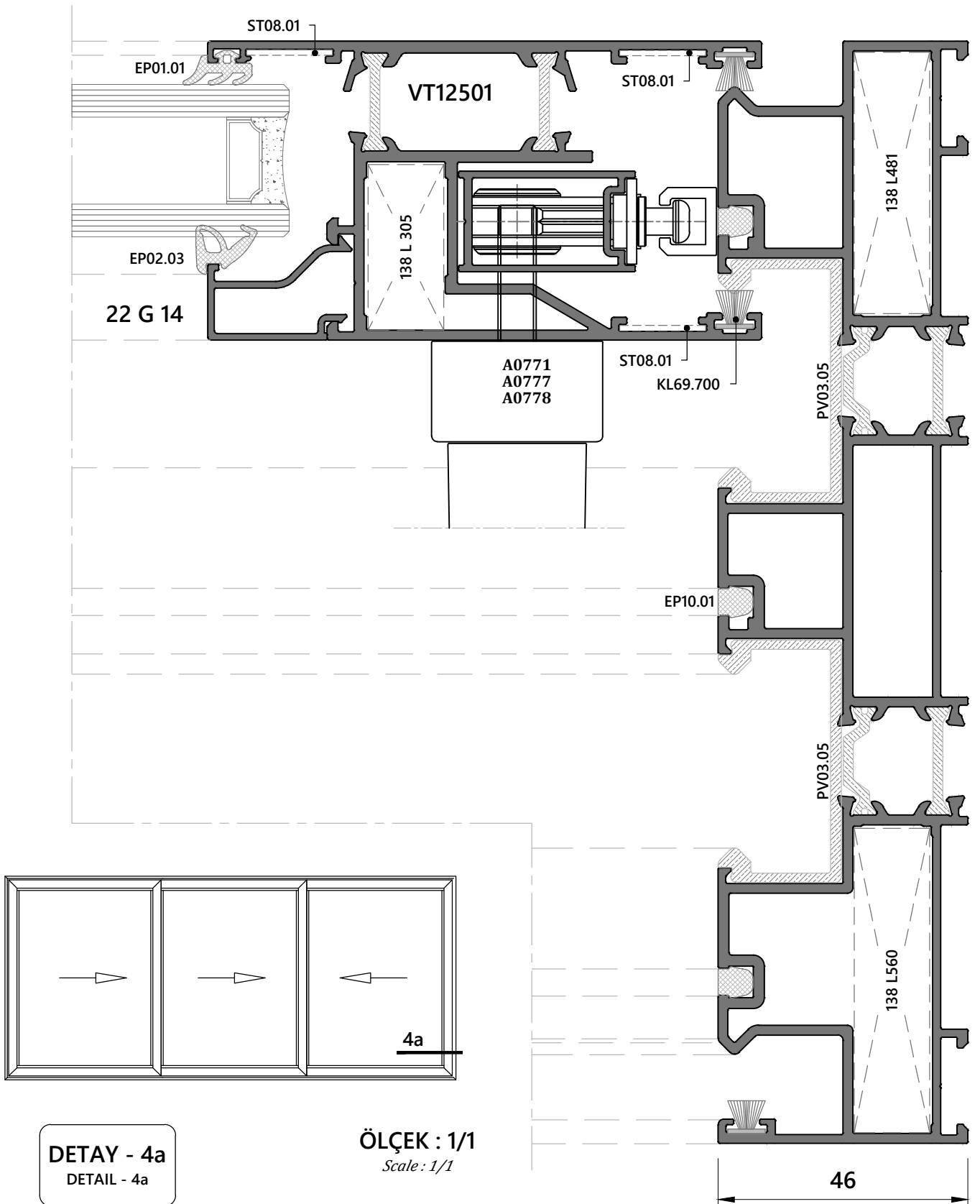

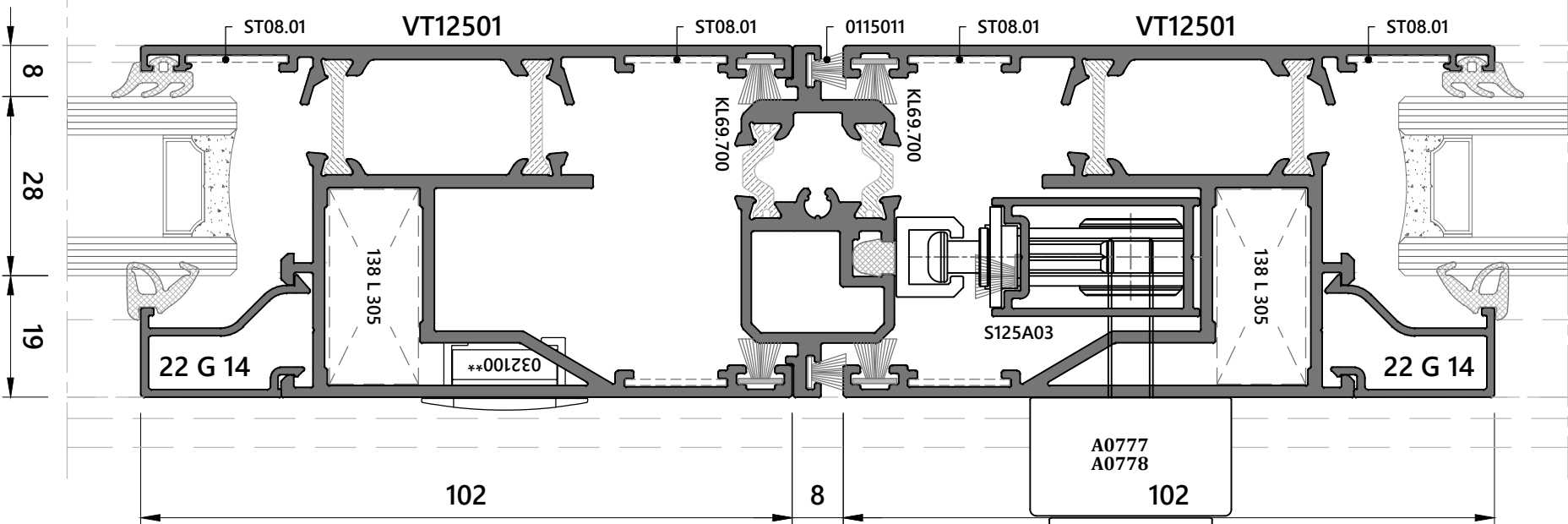
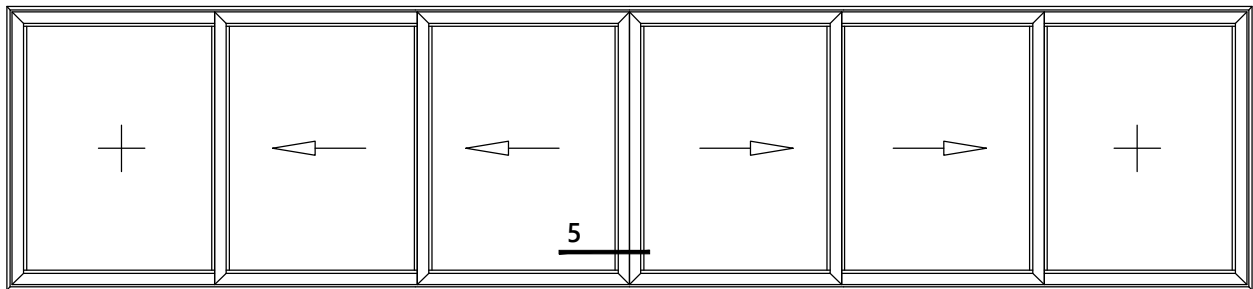





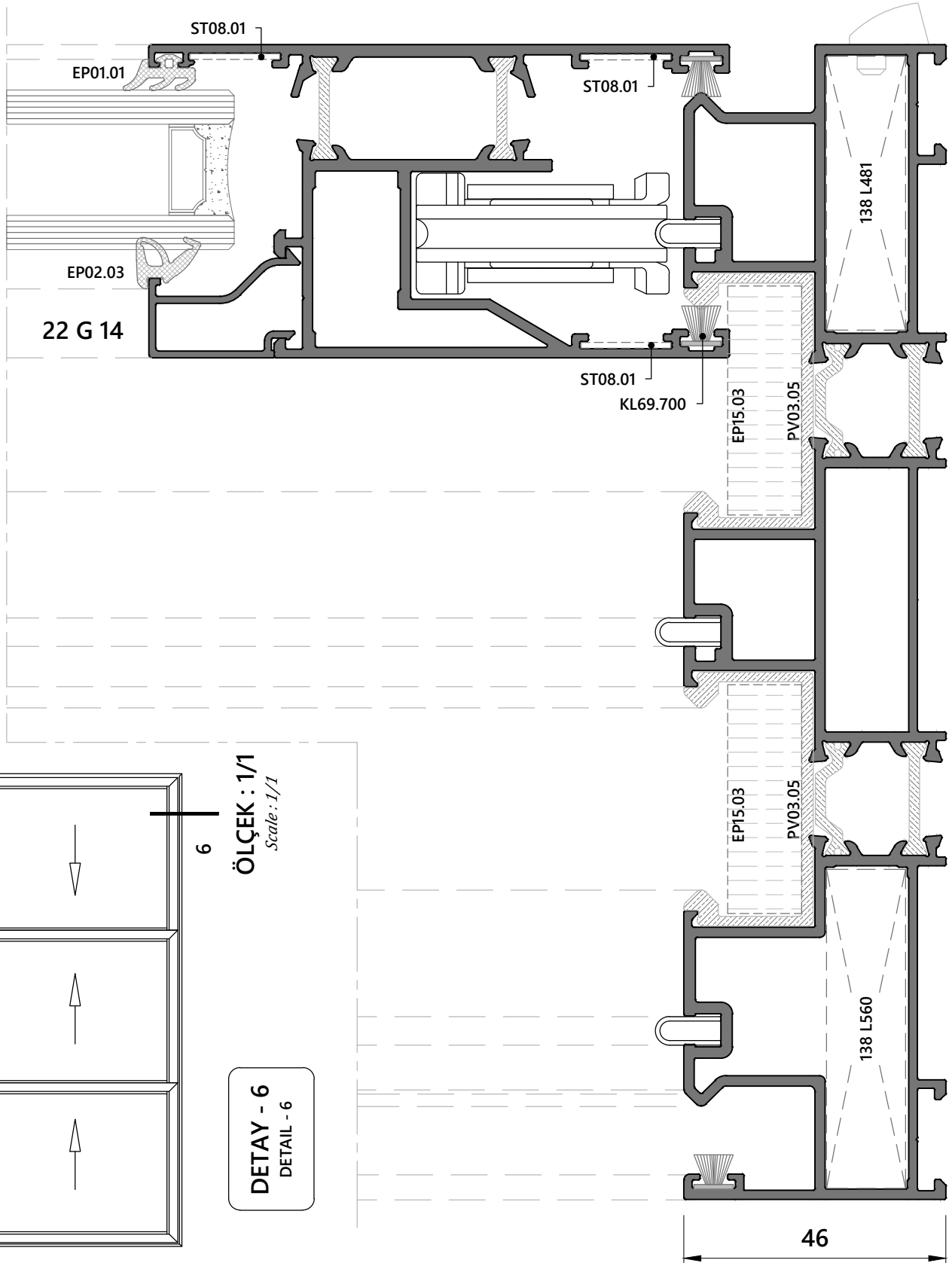







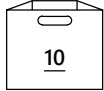



DETAY - 5
DETAIL - 5



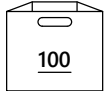

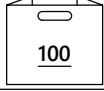

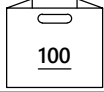







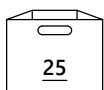

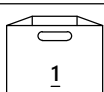

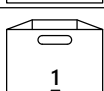

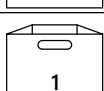

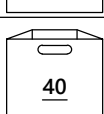

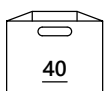
ÖLÇEK : 1/1
Scale : 1/1

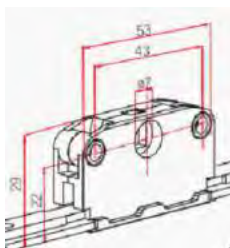

AKSESUARLAR
ACCESSORIES

ÜRÜN ÇİZİMİ <i>PRODUCT DRAWING</i>	ÜRÜN KODU <i>PRODUCT CODE</i>	RENK KODU <i>PAINT CODE</i>	RENK KODU <i>PAINT CODE</i>	ÜRÜN ADI <i>PRODUCT NAME</i>	KOLİ İÇİ <i>ADET / TAKIM</i>
	2311	00	HAM	ATRIA KALDIRSUR KOL - BAREL DELİKLİ <i>ATRIA HANDLE WITH LOCK</i>	
		01	BEYAZ		
		02	SIYAH		
		91	SILVER		
	2312	00	HAM	ATRIA KALDIRSUR KOL - BAREL DELİKSİZ <i>ATRIA HANDLE</i>	
		01	BEYAZ		
		02	SIYAH		
		91	SILVER		
	2320	00	HAM	ATRIA KALDIRSUR DIŞ ÇEKME KOL <i>ATRIA PULL HANDLE</i>	
		01	BEYAZ		
		02	SIYAH		
		91	SILVER		
	233001			ÖN ARABA <i>FRONT BOGIE</i>	
	233002			ARKA ARABA <i>REAR BOGIE</i>	
	233003			İLAVE ARABA <i>SUPPLEMENTARY BOGIE</i>	
	233004			KANAT SABİTLEME TAKOZU <i>LS400 FIXED BOGIE</i>	
	C234001			LS400 İSPANYOLET - 2100 mm <i>LS400 DRIVE GEAR</i>	
	C234002			LS400 İSPANYOLET - 2400 mm <i>LS400 DRIVE GEAR</i>	
	C234003			LS400 İSPANYOLET - 2700 mm <i>LS400 DRIVE GEAR</i>	
	C234004			LS400 İSPANYOLET (PARAPET) - 1800 mm <i>LS400 DRIVE GEAR</i>	
	233010			ARABA TAKIMI BAĞLANTI MİLİ - 2760 mm <i>CONNECTING ROD</i>	
	233011			ARABA TAKIMI BAĞLANTI MİLİ - 1760 mm <i>CONNECTING ROD</i>	
	233012			ARABA TAKIMI BAĞLANTI MİLİ - 1260 mm <i>CONNECTING ROD</i>	
	233013			ARABA TAKIMI BAĞLANTI MİLİ - 756 mm <i>CONNECTING ROD</i>	
	A234010			İSPANYOLET UZATMA - 500 mm <i>EXTENSION ROD WITHOUT LOCKING POINT</i>	

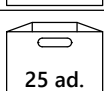
<u>ÜRÜN ÇİZİMİ</u> <i>PRODUCT DRAWING</i>	<u>ÜRÜN KODU</u> <i>PRODUCT CODE</i>	<u>RENK KODU</u> <i>PAINT CODE</i>	<u>RENK KODU</u> <i>PAINT CODE</i>	<u>ÜRÜN ADI</u> <i>PRODUCT NAME</i>	<u>KOLI İÇİ</u> <i>ADET / TAKIM</i>
	A234011			KİLİTLİ İSPANYOLET UZATMA - 500 mm <i>EXTENSION ROD WITHOUT LOCKING POINT</i>	
	A235203			LS400 İSPANYOLET YÜKSELTME KİTİ <i>LS400 LIFT&SLIDE SHIMS</i>	
	234103			LS400 ARABA TAKIMI MİL SABİTLEME KİTİ <i>LS400 INTERMEDIATE SASH KIT</i>	
	234020			LS400 KİLİTLEME KARŞILIĞI - KISA <i>LS400 LOCK POINT - SHORT</i>	
	234021			LS400 KİLİTLEME KARŞILIĞI - UZUN <i>LS400 LOCK POINT - LONG</i>	
	234022			LS400 YATAY KİLİTLEME NOKTASI <i>LS400 KEEPER</i>	
	236002			KALDIRSUR ÇİFT TARAFLI KOL SABİTLEME <i>DOUBLE HANDLE FIXING KIT / PROFILE <85</i>	
	NI0215001			YARIM BAREL 45 mm 30+10+5 <i>Cylinder 45 mm 30+10+5</i>	
	NI0215002			BAREL 90 mm 35+10+45 <i>Cylinder 90 mm 35+10+45</i>	









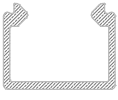
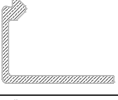

ÜRÜN ÇİZİMİ PRODUCT DRAWING	ÜRÜN KODU PRODUCT CODE	RENK KODU PAINT CODE	RENK KODU PAINT CODE	ÜRÜN ADI PRODUCT NAME	KOLİ İÇİ ADET / TAKIM
	A0771	00	HAM	SIRIUS KIVRIK CEPHE KOLU SIRIUS OFFSET WINDOW HANDLE	 25
		01	BEYAZ		
		02	SIYAH		
		91	SILVER		
	A0777	00	HAM	SIRIUS KIVRIK PENCERE KOLU - SAĞ SIRIUS OFFSET WINDOW HANDLE - RIGHT	 25
		01	BEYAZ		
		02	SIYAH		
		91	SILVER		
	A0778	00	HAM	SIRIUS KIVRIK PENCERE KOLU - SOL SIRIUS OFFSET WINDOW HANDLE - LEFT	 25
		01	BEYAZ		
		02	SIYAH		
		91	SILVER		
	034300	00	HAM	TİTAN KİLİTLİ ÇEKME KOL TITAN PULL HANDLE	 1
		01	BEYAZ		
		02	SIYAH		
		91	SILVER		
	034500	00	HAM	TİTAN ÇEKME KOL TITAN PULL HANDLE	 1
		01	BEYAZ		
		02	SIYAH		
		91	SILVER		
	034600	00	HAM	TİTAN KİLİTLİ İSPANYOLET ÇEKME KOL TITAN MULTIPPOINT LOCK PULL HANDLE	 1
		01	BEYAZ		
		02	SIYAH		
		91	SILVER		
	032000	00	HAM	FENIX SÜRME GÖMME KOL FENIX LOCK	 40
		01	BEYAZ		
		02	SIYAH		
		91	SILVER		
	032100	00	HAM	FENIX SÜRME GÖMME KOL FENIX HANDLE	 40
		01	BEYAZ		
		02	SIYAH		
		91	SILVER		
	034100	00	HAM	TİTAN KİLİTLİ GÖMME HAVUZ KOL TITAN LOCK WITH KEY	 40
		01	BEYAZ		
		02	SIYAH		
		91	SILVER		
	034410	00	HAM	TİTAN FLUSH SÜRME İSPANYOLET KOL TITAN FLUSH HANDLE	 40
		01	BEYAZ		
		02	SIYAH		
		91	SILVER		
	ISP.220.060	NİKEL KAPLAMA NICKEL PLATING		22 AKS İSPANYOLET 600-800 mm 22 AXIS STEEL SLIDING ESPOGNELETTE 600-800 mm	 50 ad.
	ISP.220.080	NİKEL KAPLAMA NICKEL PLATING		22 AKS İSPANYOLET 800-1000 mm 22 AXIS STEEL SLIDING ESPOGNELETTE 800-1000 mm	 50 ad.
	ISP.220.100	NİKEL KAPLAMA NICKEL PLATING		22 AKS İSPANYOLET 1000-1200 mm 22 AXIS STEEL SLIDING ESPOGNELETTE 1000-1200 mm	 50 ad.
	ISP.220.120	NİKEL KAPLAMA NICKEL PLATING		22 AKS İSPANYOLET 1200-1400 mm 22 AXIS STEEL SLIDING ESPOGNELETTE 1200-1400 mm	 50 ad.
	ISP.220.140	NİKEL KAPLAMA NICKEL PLATING		22 AKS İSPANYOLET 1400-1600 mm 22 AXIS STEEL SLIDING ESPOGNELETTE 1400-1600 mm	 25 ad.
	ISP.220.160	NİKEL KAPLAMA NICKEL PLATING		22 AKS İSPANYOLET 1600-1800 mm 22 AXIS STEEL SLIDING ESPOGNELETTE 1600-1800 mm	 25 ad.

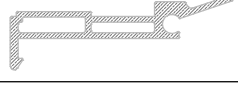
ÜRÜN ÇİZİMİ <i>PRODUCT DRAWING</i>	ÜRÜN KODU <i>PRODUCT CODE</i>	RENK KODU <i>PAINT CODE</i>	RENK KODU <i>PAINT CODE</i>	ÜRÜN ADI <i>PRODUCT NAME</i>	KOLİ İÇİ <i>ADET / TAKIM</i>
	ISP.220.180	NİKEL KAPLAMA NICKEL PLATING		22 AKS İSPANYOLET 1800-2000 mm 22 AXIS STEEL SLIDING ESPOGNELETTE 1800-2000 mm	25 ad.
	ISP.220.200	NİKEL KAPLAMA NICKEL PLATING		22 AKS İSPANYOLET 2000 mm ve ÜSTÜ 22 AXIS STEEL SLIDING ESPOGNELETTE 2000 mm & UP	25 ad.
	05034400	ÇELİK DÖKÜM STEEL CASTING		FENIX HAVUZ KOL KARŞILIK PERIMETRAL SLIDERS MICROVENTILATION	100 ad.
	A0520001	ÇELİK STEEL		SÜRME ÇELİK KARŞILIK KEEPER	400 ad.
	K5771-01	ÇELİK STEEL		ÇİFT TARAF LI KOL VİDALAMA KİTİ 55mm FIXING KITS FOR DOUBLE HANDLE 55 mm	50 ad.
		ÇELİK STEEL		RULMAN ROLLER	
	110RL.02	PLASTİK PVC		SİNEKLİK RULMAN ROLLER for FLY SCREEN	
	080KR.07	ÇELİK STEEL		SÜRME İSPANYOLET KARŞILIK KEEPER	

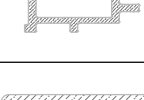
CONTALAR
GASKETS

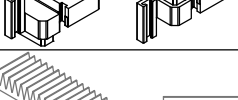
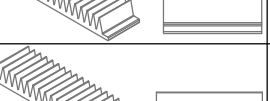
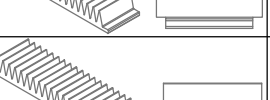
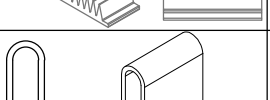
<u>ÜRÜN ÇİZİMİ</u> <i>PRODUCT DRAWING</i>	<u>ÜRÜN KODU</u> <i>PRODUCT CODE</i>	<u>ÜRÜN ADI</u> <i>PRODUCT NAME</i>	<u>BİRİM</u> <i>METRE / KOLİ</i>	<u>KOLİ İÇİ MİKTAR</u> <i>METRE / KG</i>
	EP01.01	DIŞ CAM FİTİLİ - 4,0 mm Outward Glass Gasket- 4,0 mm	 100	 15
	EP02.01	İÇ CAM FİTİLİ - 2,0 mm Inner Glass Gasket- 2,0 mm	 100	 15
	EP02.02	İÇ CAM FİTİLİ - 4,0 mm Inner Glass Gasket- 4,0 mm	 100	 15
	EP02.03	İÇ CAM FİTİLİ - 6,0 mm Inner Glass Gasket- 6,0 mm	 100	 15
	EP02.04	İÇ CAM FİTİLİ - 8,0 mm Inner Glass Gasket- 8,0 mm	 100	 15
	EP10.01	RAY KAPAMA FİTİLİ Rail Cover Gasket	 100	 15
	EP04.02	SÜRME KANAT BİNİ FİTİLİ Sliding Vent Gasket	 100	 15
	EP04.03	SÜRME KANAT BİNİ FİTİLİ Sliding Vent Gasket	 100	 15
	EP03.03	MONORAIL KASA BİNİ FİTİLİ Frame Gasket	 100	 15
	EP15.11	SİNEKLİK FİTİLİ FLY SCREEN GASKET	 100	 15
	KL69.400	KIL FİTİL 6,9x400 Brush 6,9x400	 100	 15
	KL69.500	KIL FİTİL 6,9x500 Brush 6,9x500	 100	 15
	KL69.600	KIL FİTİL 6,9x600 Brush 6,9x600	 100	 15
	KL69.700	KIL FİTİL 6,9x700 Brush 6,9x700	 100	 15
	KL69.800	KIL FİTİL 6,9x800 <i>Brush 6,9x800</i>	 100	 15
	KL69.1000	KIL FİTİL 6,9x1000 <i>Brush 6,9x1000</i>	 100	 15

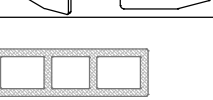
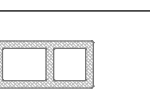
**SARF MALZEMELER
CONSUMABLES**

ÜRÜN ÇİZİMİ PRODUCT DRAWING	ÜRÜN KODU PRODUCT CODE	ÜRÜN ADI PRODUCT NAME	BİRİM METRE / KOLİ	KOLİ İÇİ MİKTAR METRE / KG
	PV03.03	KASA KANAL U PVC LST-125 Monorail Center U PVC Monorail		
	PV03.04	KASA KANAL U PVC LST-125 Monorail Center U PVC Monorail		
	PV03.05	KASA KANAL U PVC LST-125 Center U PVC		
	PV05.01	KENET PVC LST-125 Connection PVC		
	PV05.02	KENET PVC LST-125 MİNİMAL Connection PVC for Minimal		
	PV14.02	KASA CAM TAKOZU		
	PV14.03	KANAT CAM TAKOZU		
	PV07.14	SPACER - LST125		
	PV09.04	4 LÜ KANAT ADAPTÖR KAPAĞI		
	EP15.01	Alt / Üst Sızdırmazlık ST120F01		
	EP15.02	Alt / Üst Sızdırmazlık ST120F10-F11		
	EP15.03	Alt / Üst Sızdırmazlık ST120F02-F12		
	ST11.01	PASLANMAZ RAY LST-125 Stainless Rail LST-125		
	ST08.01	Paslanmaz Köşe Onbaşı 15,8*30*1,0 mm Corner Cleat		
	EP08.01	Stoper Stopper		
	EP08.02	Stoper Stopper		

KALDIRSÜR AKSESUAR SET LİSTELERİ

LIFT&SLIDE SET

EN	BOY	LS400 SET1	
600-1300	1800-2100		
Ürün Görseli	Ürün kodu	Ürün Adı	Miktar
	233001	KALDIR-SÜR ÖN ARABA LS400	1 Adet 1 Piece
	233002	KALDIR-SÜR ARKA ARABA LS400	1 Adet 1 Piece
	233013	ARABA TAKIMI BAĞLANTI MİLİ 756 MM LS401	1 Adet 1 Piece
	234001	İSPANYOLET KALDIR-SÜR H: 1800-2100 MM LS401	1 Adet 1 Piece
	234020	KALDIR-SÜR LS 400 KİLİTLEME KARŞILIĞI KISA	2 Adet 2 Piece
	234021	KALDIR-SÜR LS 400 15,5 MM İSPANYOLET YÜKSELTME PARÇASI	1 Adet 1 Piece
	A235203	KALDIRSÜR İSPANYOLET ve ARABA YÜKSELTME TAKIMI	1 Adet 1 Piece
	234103	KALDIR-SÜR ARABA TAKIMI MİL SABİTLEME KİTİ	1 Adet 1 Piece

EN	BOY	LS400 SET2	
1301-1800	1800-2100		
Ürün Görseli	Ürün kodu	Ürün Adı	Miktar
	233001	KALDIR-SÜR ÖN ARABA LS400	1 Adet 1 Piece
	233002	KALDIR-SÜR ARKA ARABA LS400	1 Adet 1 Piece
	233012	ARABA TAKIMI BAĞLANTI MİLİ 1260 MM LS401	1 Adet 1 Piece
	234001	İSPANYOLET KALDIR-SÜR H: 1800-2100 MM LS401	1 Adet 1 Piece
	234020	KALDIR-SÜR LS 400 KİLİTLEME KARŞILIĞI KISA	2 Adet 2 Piece
	234021	KALDIR-SÜR LS 400 15,5 MM İSPANYOLET YÜKSELTME PARÇASI	1 Adet 1 Piece
	A235203	KALDIRSÜR İSPANYOLET ve ARABA YÜKSELTME TAKIMI	1 Adet 1 Piece
	234103	KALDIR-SÜR ARABA TAKIMI MİL SABİTLEME KİTİ	1 Adet 1 Piece



EN	BOY	LS400 SET3	
1801-2300	1800-2100		
Ürün Görseli	Ürün kodu	Ürün Adı	Miktar
	233001	KALDIR-SÜR ÖN ARABA LS400	1 Adet 1 Piece
	233002	KALDIR-SÜR ARKA ARABA LS400	1 Adet 1 Piece
	233011	ARABA TAKIMI BAĞLANTI MİLİ 1760 MM LS401	1 Adet 1 Piece
	C234001	İSPANYOLET KALDIR-SÜR H: 1800-2100 MM LS401	1 Adet 1 Piece
	234020	KALDIR-SÜR LS 400 KİLİTLEME KARŞILIĞI KISA	2 Adet 2 Piece
	234021	KALDIR-SÜR LS 400 15,5 MM İSPANYOLET YÜKSELTME PARÇASI	1 Adet 1 Piece
	A235203	KALDIRSÜR İSPANYOLET ve ARABA YÜKSELTME TAKIMI	1 Adet 1 Piece
	234103	KALDIR-SÜR ARABA TAKIMI MİL SABİTLEME KİTİ	1 Adet 1 Piece

EN	BOY	LS400 SET4	
2301-3300	1800-2100		
Ürün Görseli	Ürün kodu	Ürün Adı	Miktar
	233001	KALDIR-SÜR ÖN ARABA LS400	1 Adet 1 Piece
	233002	KALDIR-SÜR ARKA ARABA LS400	1 Adet 1 Piece
	233010	ARABA TAKIMI BAĞLANTI MİLİ 2760 MM LS401	1 Adet 1 Piece
	C234001	İSPANYOLET KALDIR-SÜR H: 1800-2100 MM LS401	1 Adet 1 Piece
	234020	KALDIR-SÜR LS 400 KİLİTLEME KARŞILIĞI KISA	2 Adet 2 Piece
	234021	KALDIR-SÜR LS 400 15,5 MM İSPANYOLET YÜKSELTME PARÇASI	1 Adet 1 Piece
	A235203	KALDIRSÜR İSPANYOLET ve ARABA YÜKSELTME TAKIMI	1 Adet 1 Piece
	234103	KALDIR-SÜR ARABA TAKIMI MİL SABİTLEME KİTİ	1 Adet 1 Piece

EN	BOY	LS400 SET5	
600-1300	2101-2400		
Ürün Görseli	Ürün kodu	Ürün Adı	Miktar
	233001	KALDIR-SÜR ÖN ARABA LS400	1 Adet 1 Piece
	233002	KALDIR-SÜR ARKA ARABA LS400	1 Adet 1 Piece
	233013	ARABA TAKIMI BAĞLANTI MİLİ 756 MM LS401	1 Adet 1 Piece
	234002	İSPANYOLET KALDIR-SÜR H: 2101-2400 MM LS401	1 Adet 1 Piece
	234020	KALDIR-SÜR LS 400 KİLİTLEME KARŞILIĞI KISA	2 Adet 2 Piece
	234021	KALDIR-SÜR LS 400 15,5 MM İSPANYOLET YÜKSELTME PARÇASI	1 Adet 1 Piece
	A235203	KALDIRSÜR İSPANYOLET ve ARABA YÜKSELTME TAKIMI	1 Adet 1 Piece
	234103	KALDIR-SÜR ARABA TAKIMI MİL SABİTLEME KİTİ	1 Adet 1 Piece

EN	BOY	LS400 SET6	
1301-1800	2101-2400		
Ürün Görseli	Ürün kodu	Ürün Adı	Miktar
	233001	KALDIR-SÜR ÖN ARABA LS400	1 Adet 1 Piece
	233002	KALDIR-SÜR ARKA ARABA LS400	1 Adet 1 Piece
	233012	ARABA TAKIMI BAĞLANTI MİLİ 1260 MM LS401	1 Adet 1 Piece
	C234002	İSPANYOLET KALDIR-SÜR H: 2101-2400 MM LS401	1 Adet 1 Piece
	234020	KALDIR-SÜR LS 400 KİLİTLEME KARŞILIĞI KISA	2 Adet 2 Piece
	234021	KALDIR-SÜR LS 400 15,5 MM İSPANYOLET YÜKSELTME PARÇASI	1 Adet 1 Piece
	A235203	KALDIRSÜR İSPANYOLET ve ARABA YÜKSELTME TAKIMI	1 Adet 1 Piece
	234103	KALDIR-SÜR ARABA TAKIMI MİL SABİTLEME KİTİ	1 Adet 1 Piece

EN	BOY	LS400 SET7	
1801-2300	2101-2400		
Ürün Görseli	Ürün kodu	Ürün Adı	Miktar
	233001	KALDIR-SÜR ÖN ARABA LS400	1 Adet 1 Piece
	233002	KALDIR-SÜR ARKA ARABA LS400	1 Adet 1 Piece
	233011	ARABA TAKIMI BAĞLANTI MİLİ 1760 MM LS401	1 Adet 1 Piece
	C234002	İSPANYOLET KALDIR-SÜR H: 2101-2400 MM LS401	1 Adet 1 Piece
	234020	KALDIR-SÜR LS 400 KİLİTLEME KARŞILIĞI KISA	2 Adet 2 Piece
	234021	KALDIR-SÜR LS 400 15,5 MM İSPANYOLET YÜKSELTME PARÇASI	1 Adet 1 Piece
	A235203	KALDIRSÜR İSPANYOLET ve ARABA YÜKSELTME TAKIMI	1 Adet 1 Piece
	234103	KALDIR-SÜR ARABA TAKIMI MİL SABİTLEME KİTİ	1 Adet 1 Piece

EN	BOY	LS400 SET8	
2301-3300	2101-2400		
Ürün Görseli	Ürün kodu	Ürün Adı	Miktar
	233001	KALDIR-SÜR ÖN ARABA LS400	1 Adet 1 Piece
	233002	KALDIR-SÜR ARKA ARABA LS400	1 Adet 1 Piece
	233010	ARABA TAKIMI BAĞLANTI MİLİ 2760 MM LS401	1 Adet 1 Piece
	C234002	İSPANYOLET KALDIR-SÜR H: 2101-2400 MM LS401	1 Adet 1 Piece
	234020	KALDIR-SÜR LS 400 KİLİTLEME KARŞILIĞI KISA	2 Adet 2 Piece
	234021	KALDIR-SÜR LS 400 15,5 MM İSPANYOLET YÜKSELTME PARÇASI	1 Adet 1 Piece
	A235203	KALDIRSÜR İSPANYOLET ve ARABA YÜKSELTME TAKIMI	1 Adet 1 Piece
	234103	KALDIR-SÜR ARABA TAKIMI MİL SABİTLEME KİTİ	1 Adet 1 Piece



EN	BOY	LS400 SET9	
600-1300	2401-2700		
Ürün Görseli	Ürün kodu	Ürün Adı	Miktar
	233001	KALDIR-SÜR ÖN ARABA LS400	1 Adet 1 Piece
	233002	KALDIR-SÜR ARKA ARABA LS400	1 Adet 1 Piece
	233013	ARABA TAKIMI BAĞLANTI MİLİ 756 MM LS401	1 Adet 1 Piece
	C234003	İSPANYOLET KALDIR-SÜR H: 2401-2700 MM LS401	1 Adet 1 Piece
	234020	KALDIR-SÜR LS 400 KİLİTLEME KARŞILIĞI KISA	2 Adet 2 Piece
	234021	KALDIR-SÜR LS 400 15,5 MM İSPANYOLET YÜKSELTME PARÇASI	1 Adet 1 Piece
	A235203	KALDIRSÜR İSPANYOLET ve ARABA YÜKSELTME TAKIMI	1 Adet 1 Piece
	234103	KALDIR-SÜR ARABA TAKIMI MİL SABİTLEME KİTİ	1 Adet 1 Piece



EN	BOY	LS400 SET10	
1301-1800	2401-2700		
Ürün Görseli	Ürün kodu	Ürün Adı	Miktar
	233001	KALDIR-SÜR ÖN ARABA LS400	1 Adet 1 Piece
	233002	KALDIR-SÜR ARKA ARABA LS400	1 Adet 1 Piece
	233012	ARABA TAKIMI BAĞLANTI MİLİ 1260 MM LS401	1 Adet 1 Piece
	C234003	İSPANYOLET KALDIR-SÜR H: 2401-2700 MM LS401	1 Adet 1 Piece
	234020	KALDIR-SÜR LS 400 KİLİTLEME KARŞILIĞI KISA	2 Adet 2 Piece
	234021	KALDIR-SÜR LS 400 15,5 MM İSPANYOLET YÜKSELTME PARÇASI	1 Adet 1 Piece
	A235203	KALDIRSÜR İSPANYOLET ve ARABA YÜKSELTME TAKIMI	1 Adet 1 Piece
	234103	KALDIR-SÜR ARABA TAKIMI MİL SABİTLEME KİTİ	1 Adet 1 Piece

EN	BOY	LS400 SET11	
1801-2300	2401-2700		
Ürün Görseli	Ürün kodu	Ürün Adı	Miktar
	233001	KALDIR-SÜR ÖN ARABA LS400	1 Adet 1 Piece
	233002	KALDIR-SÜR ARKA ARABA LS400	1 Adet 1 Piece
	233011	ARABA TAKIMI BAĞLANTI MİLİ 1760 MM LS401	1 Adet 1 Piece
	C234003	İSPANYOLET KALDIR-SÜR H: 2401-2700 MM LS401	1 Adet 1 Piece
	234020	KALDIR-SÜR LS 400 KİLİTLEME KARŞILIĞI KISA	2 Adet 2 Piece
	234021	KALDIR-SÜR LS 400 15,5 MM İSPANYOLET YÜKSELTME PARÇASI	1 Adet 1 Piece
	A235203	KALDIRSÜR İSPANYOLET ve ARABA YÜKSELTME TAKIMI	1 Adet 1 Piece
	234103	KALDIR-SÜR ARABA TAKIMI MİL SABİTLEME KİTİ	1 Adet 1 Piece









EN	BOY	LS400 SET12	
2301-3300	2401-2700		
Ürün Görseli	Ürün kodu	Ürün Adı	Miktar
	233001	KALDIR-SÜR ÖN ARABA LS400	1 Adet 1 Piece
	233002	KALDIR-SÜR ARKA ARABA LS400	1 Adet 1 Piece
	233010	ARABA TAKIMI BAĞLANTI MİLİ 2760 MM LS401	1 Adet 1 Piece
	C234003	İSPANYOLET KALDIR-SÜR H: 2401-2700 MM LS401	1 Adet 1 Piece
	234020	KALDIR-SÜR LS 400 KİLİTLEME KARŞILIĞI KISA	2 Adet 2 Piece
	234021	KALDIR-SÜR LS 400 15,5 MM İSPANYOLET YÜKSELTME PARÇASI	1 Adet 1 Piece
	A235203	KALDIRSÜR İSPANYOLET ve ARABA YÜKSELTME TAKIMI	1 Adet 1 Piece
	234103	KALDIR-SÜR ARABA TAKIMI MİL SABİTLEME KİTİ	1 Adet 1 Piece







EN	BOY	LS400 SET13	
600-1300	2701-3200		
Ürün Görseli	Ürün kodu	Ürün Adı	Miktar
	233001	KALDIR-SÜR ÖN ARABA LS400	1 Adet 1 Piece
	233002	KALDIR-SÜR ARKA ARABA LS400	1 Adet 1 Piece
	233013	ARABA TAKIMI BAĞLANTI MİLİ 756 MM LS401	1 Adet 1 Piece
	234003	İSPANYOLET KALDIR-SÜR H: 2401-2700 MM LS401	1 Adet 1 Piece
	234010	KALDIR-SÜR İSPANYOLET UZATMA - 500 mm	1 Adet 1 Piece
	234020	KALDIR-SÜR LS 400 KİLİTLEME KARŞILIĞI KISA	2 Adet 2 Piece
	234021	KALDIR-SÜR LS 400 15,5 MM İSPANYOLET YÜKSELTME PARÇASI	1 Adet 1 Piece
	A235203	KALDIRSÜR İSPANYOLET ve ARABA YÜKSELTME TAKIMI	1 Adet 1 Piece
	234103	KALDIR-SÜR ARABA TAKIMI MİL SABİTLEME KİTİ	1 Adet 1 Piece





EN	BOY	LS400 SET14	
1301-1800	2701-3200		
Ürün Görseli	Ürün kodu	Ürün Adı	Miktar
	233001	KALDIR-SÜR ÖN ARABA LS400	1 Adet 1 Piece
	233002	KALDIR-SÜR ARKA ARABA LS400	1 Adet 1 Piece
	233012	ARABA TAKIMI BAĞLANTI MİLİ 1260 MM LS401	1 Adet 1 Piece
	234003	İSPANYOLET KALDIR-SÜR H: 2401-2700 MM LS401	1 Adet 1 Piece
	234010	KALDIR-SÜR İSPANYOLET UZATMA - 500 mm	1 Adet 1 Piece
	234020	KALDIR-SÜR LS 400 KİLİTLEME KARŞILIĞI KISA	2 Adet 2 Piece
	234021	KALDIR-SÜR LS 400 15,5 MM İSPANYOLET YÜKSELTME PARÇASI	1 Adet 1 Piece
	A235203	KALDIRSÜR İSPANYOLET ve ARABA YÜKSELTME TAKIMI	1 Adet 1 Piece
	234103	KALDIR-SÜR ARABA TAKIMI MİL SABİTLEME KİTİ	1 Adet 1 Piece



EN	BOY	LS400 SET15	
1801-2300	2701-3200		
Ürün Görseli	Ürün kodu	Ürün Adı	Miktar
	233001	KALDIR-SÜR ÖN ARABA LS400	1 Adet 1 Piece
	233002	KALDIR-SÜR ARKA ARABA LS400	1 Adet 1 Piece
	233011	ARABA TAKIMI BAĞLANTI MİLİ 1760 MM LS401	1 Adet 1 Piece
	234003	İSPANYOLET KALDIR-SÜR H: 2401-2700 MM LS401	1 Adet 1 Piece
	234010	KALDIR-SÜR İSPANYOLET UZATMA - 500 mm	1 Adet 1 Piece
	234020	KALDIR-SÜR LS 400 KİLİTLEME KARŞILIĞI KISA	2 Adet 2 Piece
	234021	KALDIR-SÜR LS 400 15,5 MM İSPANYOLET YÜKSELTME PARÇASI	1 Adet 1 Piece
	A235203	KALDIRSÜR İSPANYOLET ve ARABA YÜKSELTME TAKIMI	1 Adet 1 Piece
	234103	KALDIR-SÜR ARABA TAKIMI MİL SABİTLEME KİTİ	1 Adet 1 Piece

EN	BOY	LS400 SET16	
2301-3300	2701-3200		
Ürün Görseli	Ürün kodu	Ürün Adı	Miktar
	233001	KALDIR-SÜR ÖN ARABA LS400	1 Adet 1 Piece
	233002	KALDIR-SÜR ARKA ARABA LS400	1 Adet 1 Piece
	233010	ARABA TAKIMI BAĞLANTI MİLİ 2760 MM LS401	1 Adet 1 Piece
	234003	İSPANYOLET KALDIR-SÜR H: 2401-2700 MM LS401	1 Adet 1 Piece
	234010	KALDIR-SÜR İSPANYOLET UZATMA - 500 mm	1 Adet 1 Piece
	234020	KALDIR-SÜR LS 400 KİLİTLEME KARŞILIĞI KISA	2 Adet 2 Piece
	234021	KALDIR-SÜR LS 400 15,5 MM İSPANYOLET YÜKSELTME PARÇASI	1 Adet 1 Piece
	A235203	KALDIRSÜR İSPANYOLET ve ARABA YÜKSELTME TAKIMI	1 Adet 1 Piece
	234103	KALDIR-SÜR ARABA TAKIMI MİL SABİTLEME KİTİ	1 Adet 1 Piece

EN	BOY	PARAPET SET1	
600-1300	Max: 1800		
Ürün Görseli	Ürün kodu	Ürün Adı	Miktar
	233001	KALDIR-SÜR ÖN ARABA LS400	1 Adet 1 Piece
	233002	KALDIR-SÜR ARKA ARABA LS400	1 Adet 1 Piece
	233013	ARABA TAKIMI BAĞLANTI MİLİ 756 MM LS401	1 Adet 1 Piece
	234004	PARAPET ÜSTÜ KALDIR-SÜR İSPANYOLET	1 Adet 1 Piece
	234020	KALDIR-SÜR LS 400 KİLİTLEME KARŞILIĞI KISA	2 Adet 2 Piece
	234021	KALDIR-SÜR LS 400 15,5 MM İSPANYOLET YÜKSELTME PARÇASI	1 Adet 1 Piece
	A235203	KALDIRSÜR İSPANYOLET ve ARABA YÜKSELTME TAKIMI	1 Adet 1 Piece
	234103	KALDIR-SÜR ARABA TAKIMI MİL SABİTLEME KİTİ	1 Adet 1 Piece

EN	BOY	PARAPET SET2	
1301-1800	Max: 1800		
Ürün Görseli	Ürün kodu	Ürün Adı	Miktar
	233001	KALDIR-SÜR ÖN ARABA LS400	1 Adet 1 Piece
	233002	KALDIR-SÜR ARKA ARABA LS400	1 Adet 1 Piece
	233012	ARABA TAKIMI BAĞLANTI MİLİ 1260 MM LS401	1 Adet 1 Piece
	234004	PARAPET ÜSTÜ KALDIR-SÜR İSPANYOLET	1 Adet 1 Piece
	234020	KALDIR-SÜR LS 400 KİLİTLEME KARŞILIĞI KISA	2 Adet 2 Piece
	234021	KALDIR-SÜR LS 400 15,5 MM İSPANYOLET YÜKSELTME PARÇASI	1 Adet 1 Piece
	A235203	KALDIRSÜR İSPANYOLET ve ARABA YÜKSELTME TAKIMI	1 Adet 1 Piece
	234103	KALDIR-SÜR ARABA TAKIMI MİL SABİTLEME KİTİ	1 Adet 1 Piece

EN	BOY	PARAPET SET3	
1801-2300	Max: 1800		
Ürün Görseli	Ürün kodu	Ürün Adı	Miktar
	233001	KALDIR-SÜR ÖN ARABA LS400	1 Adet 1 Piece
	233002	KALDIR-SÜR ARKA ARABA LS400	1 Adet 1 Piece
	233011	ARABA TAKIMI BAĞLANTI MİLİ 1760 MM LS401	1 Adet 1 Piece
	234004	PARAPET ÜSTÜ KALDIR-SÜR İSPANYOLET	1 Adet 1 Piece
	234020	KALDIR-SÜR LS 400 KİLİTLEME KARŞILIĞI KISA	2 Adet 2 Piece
	234021	KALDIR-SÜR LS 400 15,5 MM İSPANYOLET YÜKSELTME PARÇASI	1 Adet 1 Piece
	A235203	KALDIRSÜR İSPANYOLET ve ARABA YÜKSELTME TAKIMI	1 Adet 1 Piece
	234103	KALDIR-SÜR ARABA TAKIMI MİL SABİTLEME KİTİ	1 Adet 1 Piece

EN	BOY	PARAPET SET4	
2301-3300	Max: 1800		
Ürün Görseli	Ürün kodu	Ürün Adı	Miktar
	233001	KALDIR-SÜR ÖN ARABA LS400	1 Adet 1 Piece
	233002	KALDIR-SÜR ARKA ARABA LS400	1 Adet 1 Piece
	233010	ARABA TAKIMI BAĞLANTI MİLİ 2760 MM LS401	1 Adet 1 Piece
	234004	PARAPET ÜSTÜ KALDIR-SÜR İSPANYOLET	1 Adet 1 Piece
	234020	KALDIR-SÜR LS 400 KİLİTLEME KARŞILIĞI KISA	2 Adet 2 Piece
	234021	KALDIR-SÜR LS 400 15,5 MM İSPANYOLET YÜKSELTME PARÇASI	1 Adet 1 Piece
	A235203	KALDIRSÜR İSPANYOLET ve ARABA YÜKSELTME TAKIMI	1 Adet 1 Piece
	234103	KALDIR-SÜR ARABA TAKIMI MİL SABİTLEME KİTİ	1 Adet 1 Piece

KOL SEÇİM - ALTERNATİF 1

Ürün Görseli	Ürün kodu	Ürün Adı	Miktar
	2312 (İÇ)	ATRIA KALDIRSUR KOL - BAREL DELİKSİZ	1 Adet 1 Piece
	2320 (DIŞ)	ATRIA KALDIRSUR DIŞ ÇEKME KOL	1 Adet 1 Piece



KOL SEÇİM - ALTERNATİF 2

Ürün Görseli	Ürün kodu	Ürün Adı	Miktar
	2311 (İÇ)	ATRIA KALDIRSUR KOL - BAREL DELİKLİ	1 Adet 1 Piece
	2320 (DIŞ)	ATRIA KALDIRSUR DIŞ ÇEKME KOL	1 Adet 1 Piece
	NI0215001	YARIM BAREL 45 mm 30+10+5	1 Adet 1 Piece

KOL SEÇİM - ALTERNATİF 3

Ürün Görseli	Ürün kodu	Ürün Adı	Miktar
	2312 (İÇ/DIŞ)	ATRIA KALDIRSUR KOL - BAREL DELİKSİZ	2 Adet 2 Piece
	236002	ATRIA KALDIRSUR KOL - BAREL DELİKSİZ	1 Adet 1 Piece

KOL SEÇİM - ALTERNATİF 4

Ürün Görseli	Ürün kodu	Ürün Adı	Miktar
	2311 (İÇ/DIŞ)	ATRIA KALDIRSUR KOL - BAREL DELİKLİ	2 Adet 2 Piece
	236002	ATRIA KALDIRSUR KOL - BAREL DELİKSİZ	1 Adet 1 Piece
	NI0215002	BAREL 90 mm 35+10+45	1 Adet 1 Piece

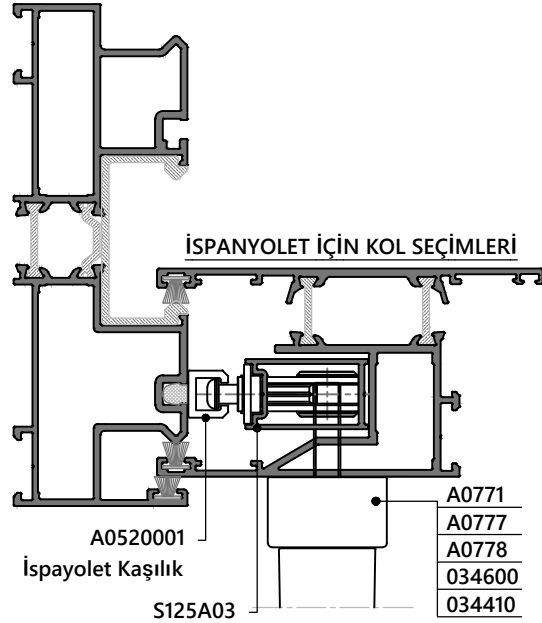

İspayolet ölçüsü kadar

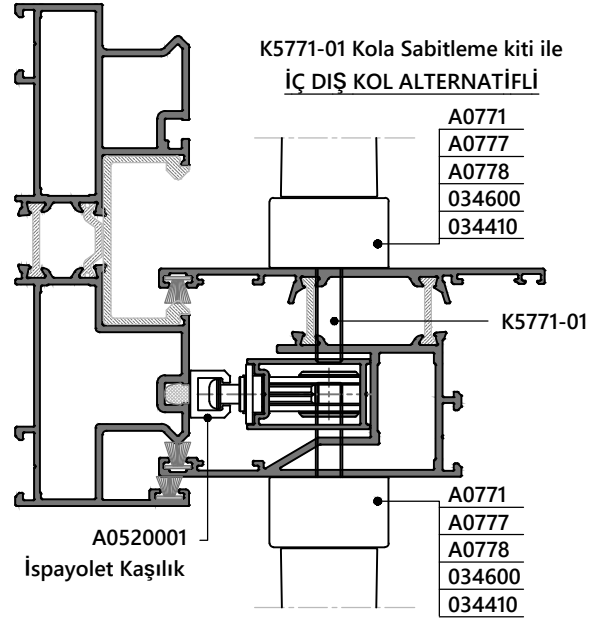

KOD CODE	İSPANYOLET SEÇİMİ							A0520001 İSPANYOLET KARŞILIK	
	KANAT YÜKSEKLİK (H)								
	600 - 800	800 - 1000	1000 - 1200	1200 - 1400	1400 - 1600	1600-1800	1800-2000	2000 - >	
ISP.220.060	1 Adet 1 Piece								2 Adet 2 Piece
ISP.220.080		1 Adet 1 Piece							2 Adet 2 Piece
ISP.220.100			1 Adet 1 Piece						3 Adet 3 Piece
ISP.220.120				1 Adet 1 Piece					3 Adet 3 Piece
ISP.220.140					1 Adet 1 Piece				3 Adet 3 Piece
ISP.220.160						1 Adet 1 Piece			3 Adet 3 Piece
ISP.220.180							1 Adet 1 Piece		4 Adet 4 Piece
ISP.220.200								1 Adet 1 Piece	4 Adet 4 Piece

HAVUZ KOL SEÇİMLERİ

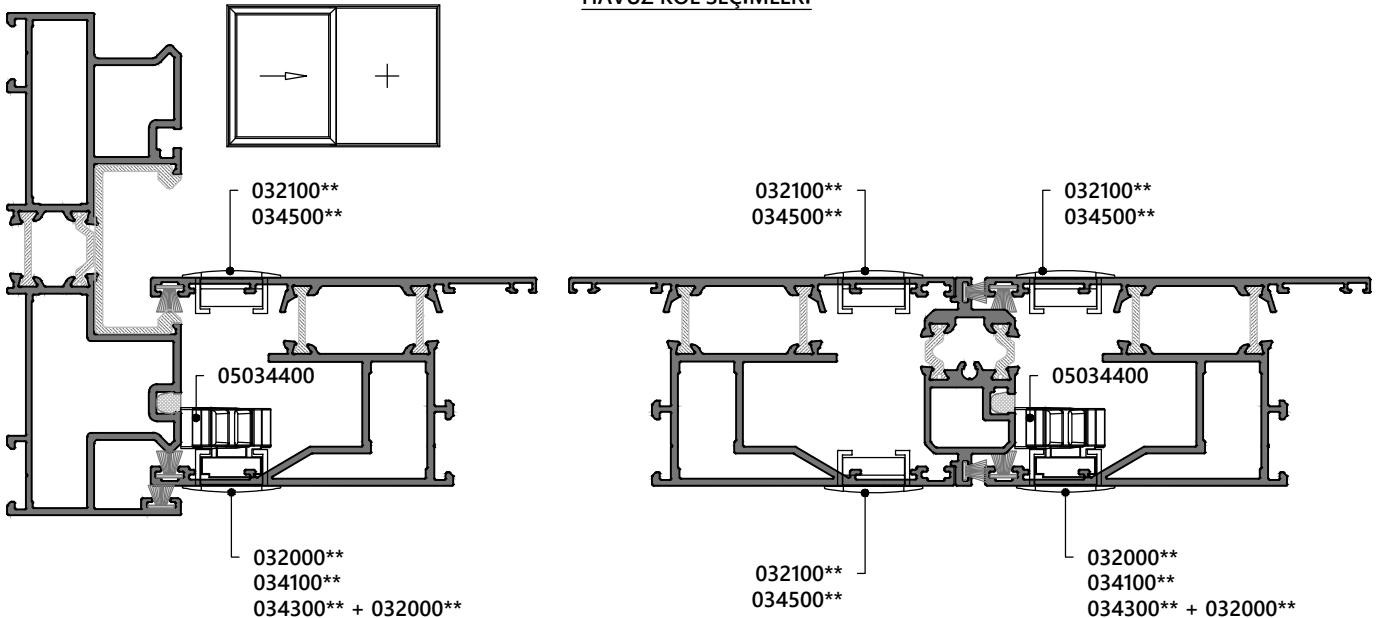

İMALAT & MONTAJ DETAYLARI
MANUFACTURING & INSTALLATION DETAILS

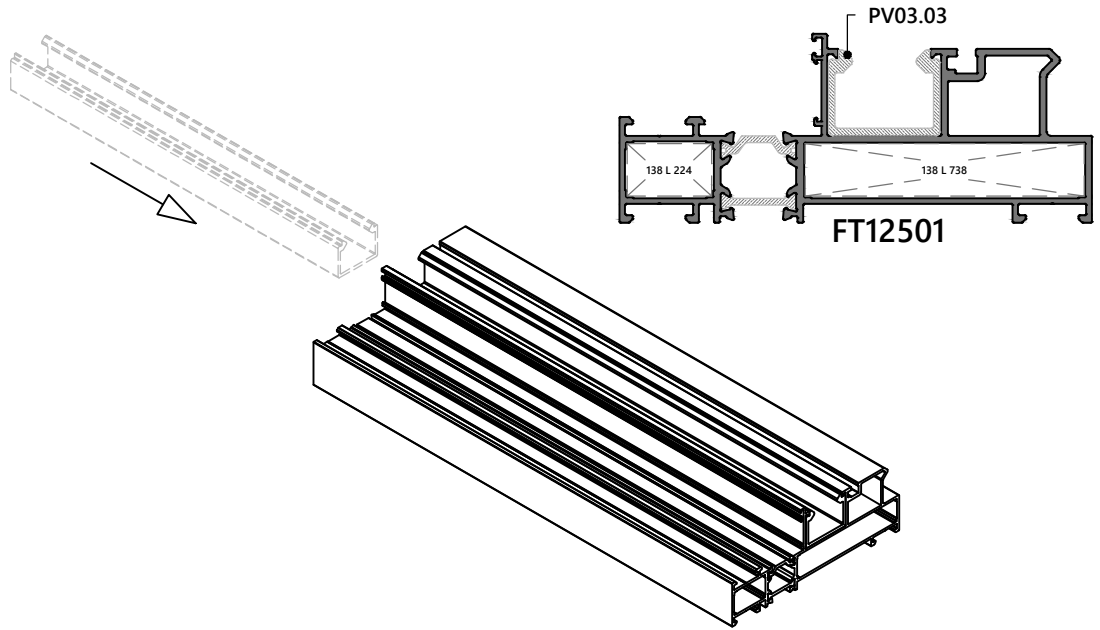

PV03.03 PVC KASA IZALOTÖRÜ FT12501
KASA Profili miktarı kadar olmalıdır.
İmalat aşamasında, birlikte kesimleri yapılmalıdır.

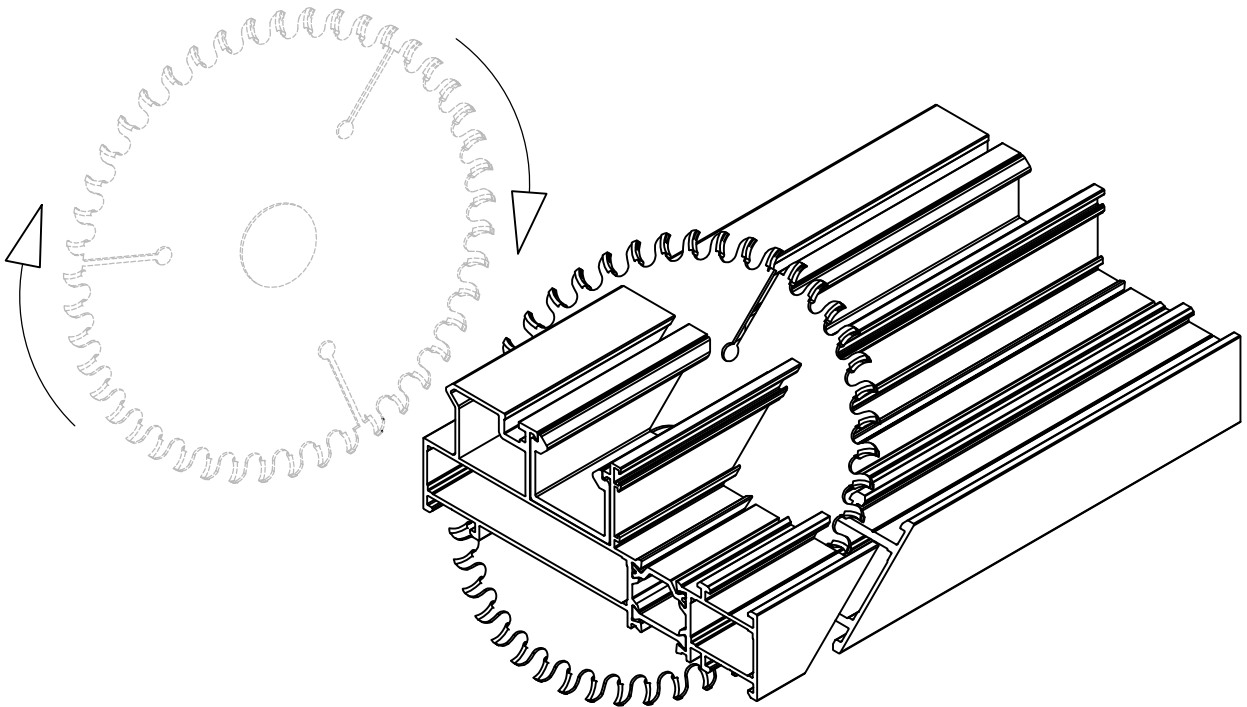

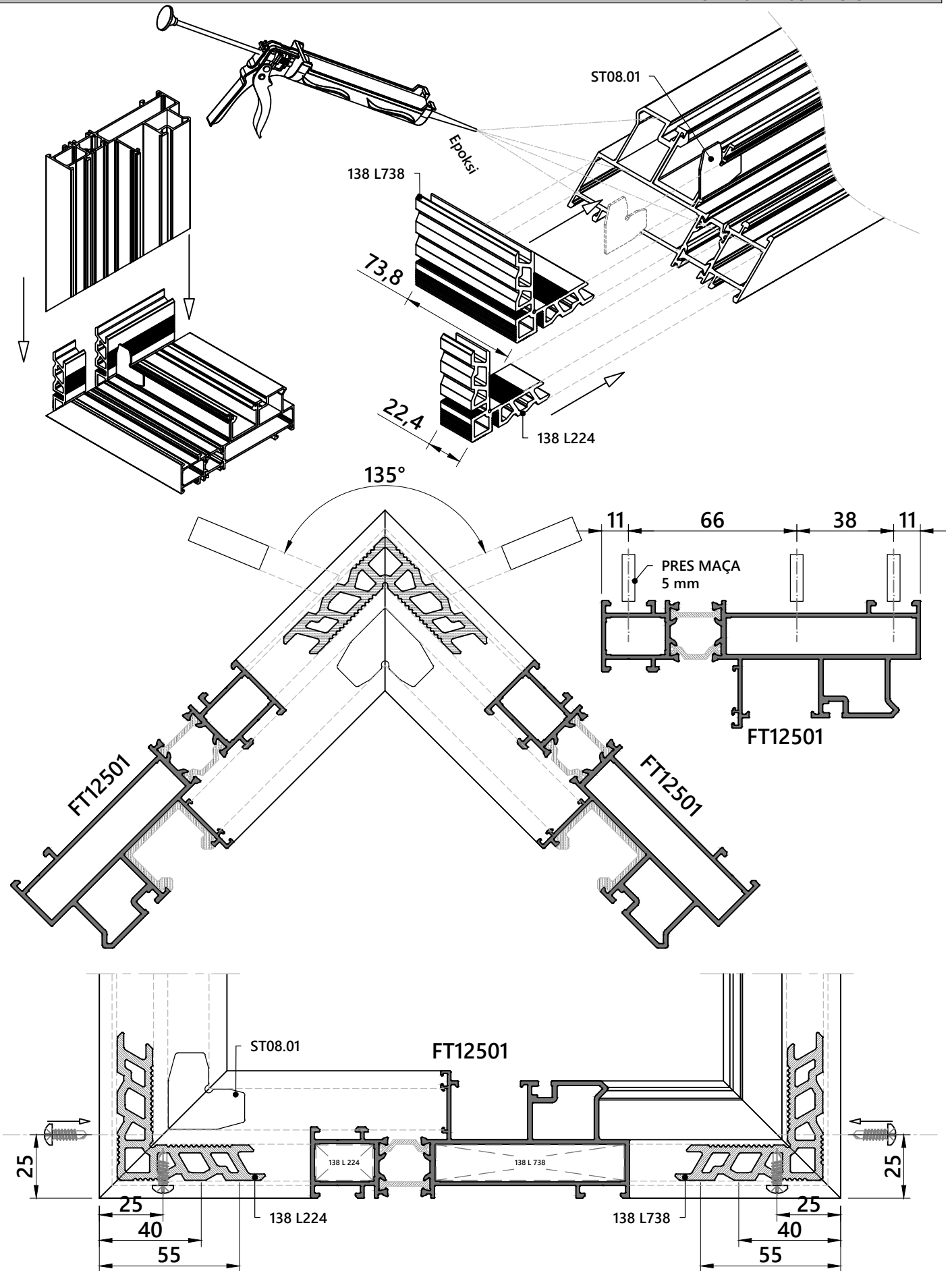

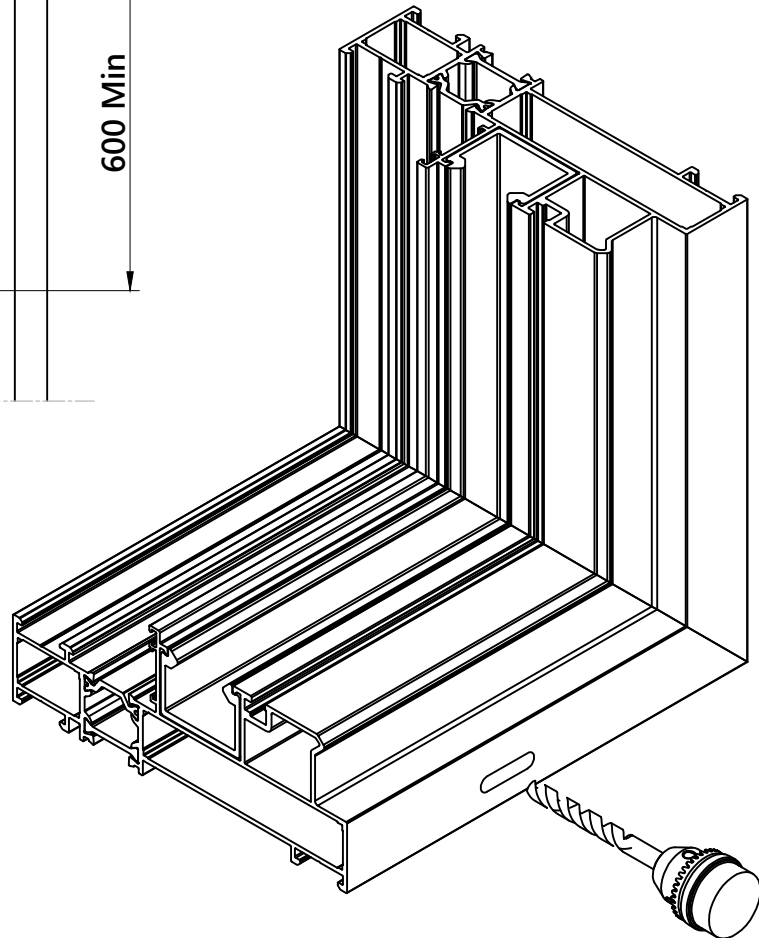
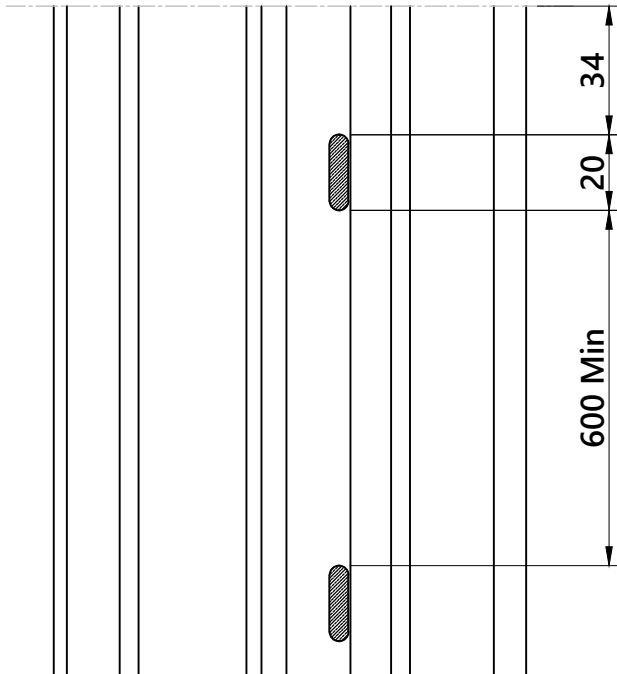
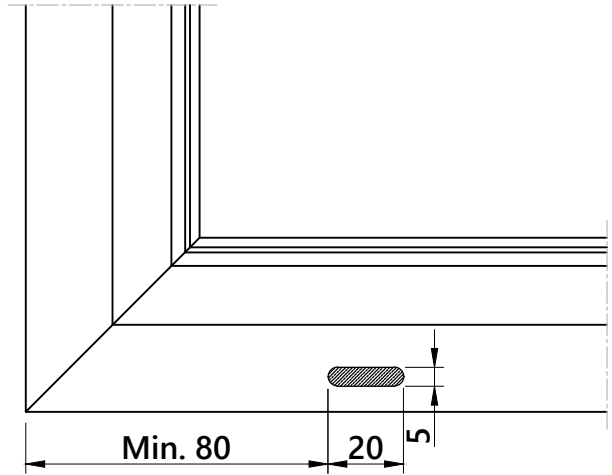
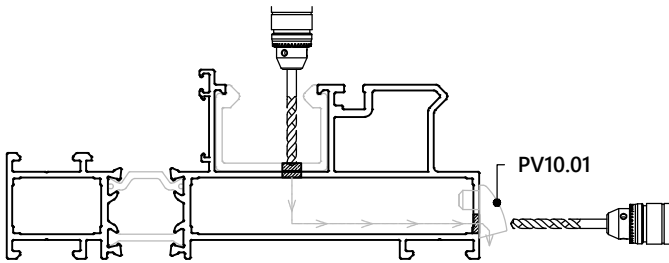

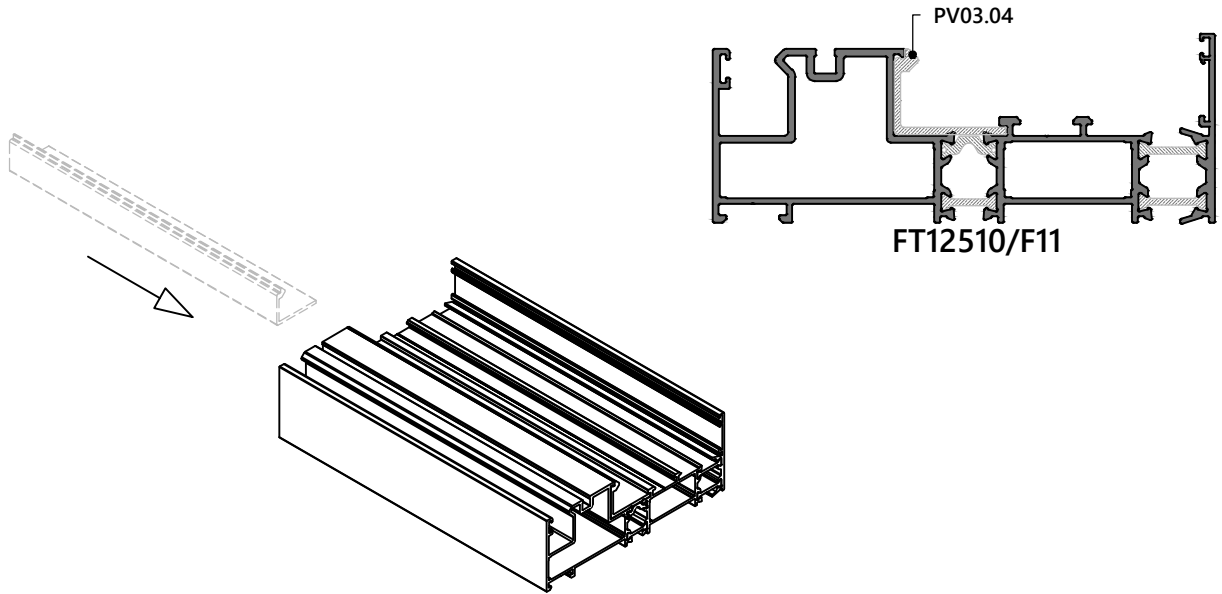

PV03.04 PVC KASA IZALOTÖRÜ FT12510 veya FT12511
KASA Profilleri miktarı kadar olmalıdır.
İmalat aşamasında, birlikte kesimleri yapılmalıdır.

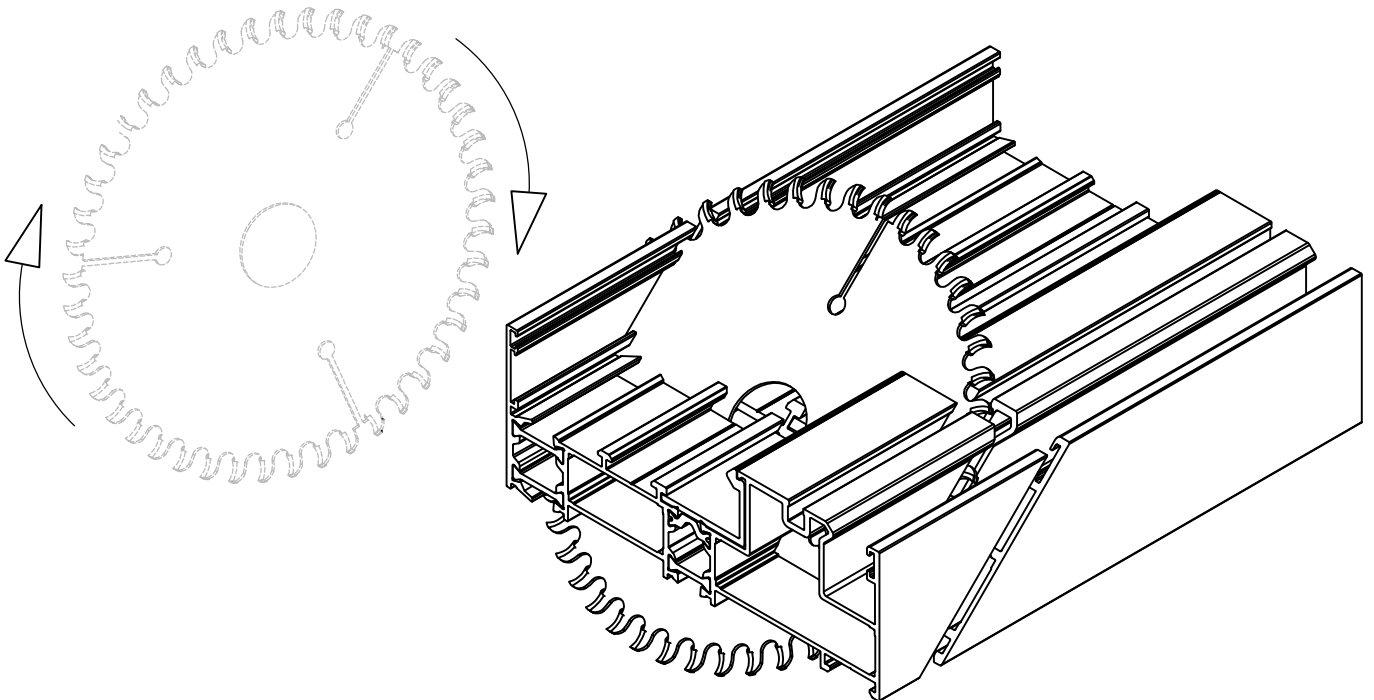

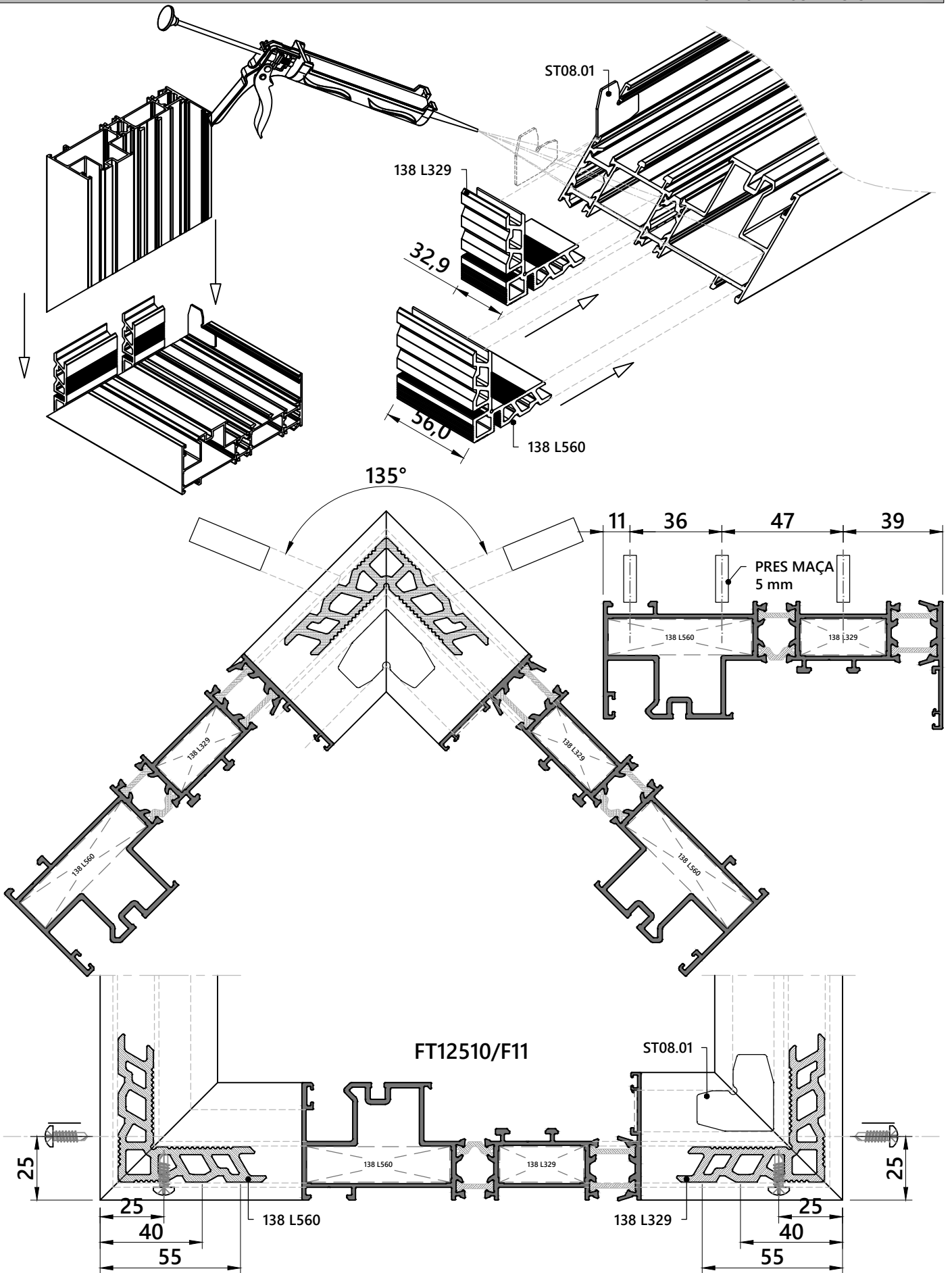

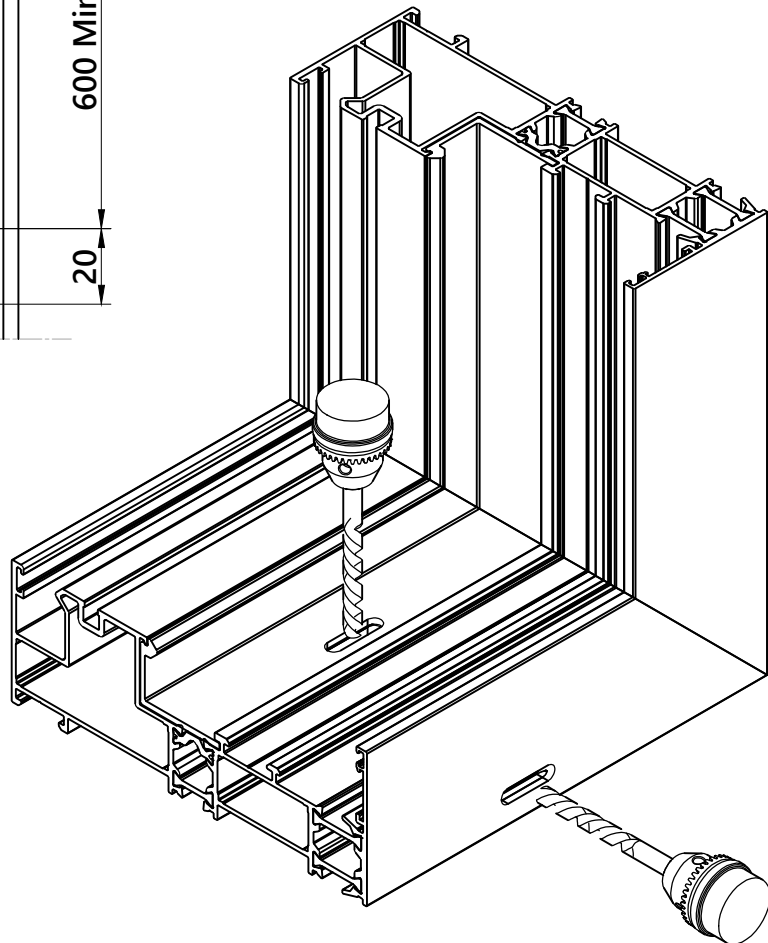
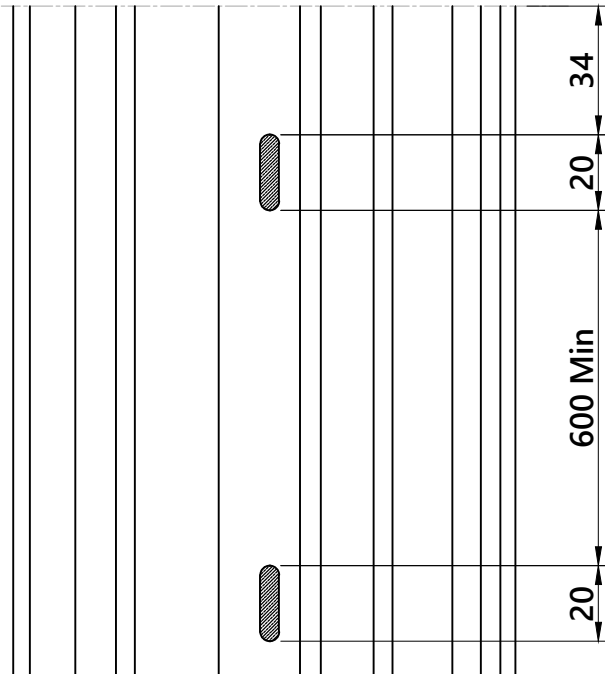
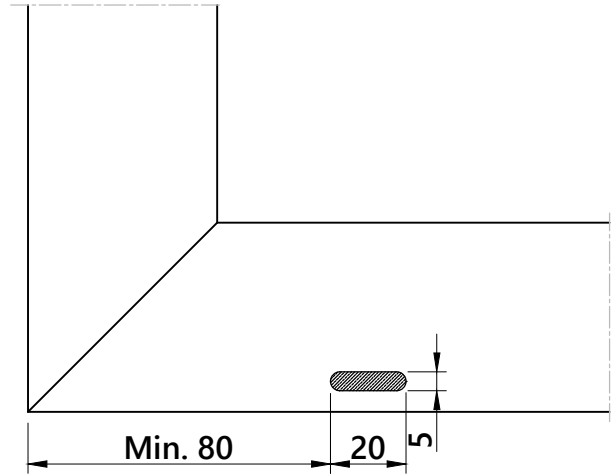
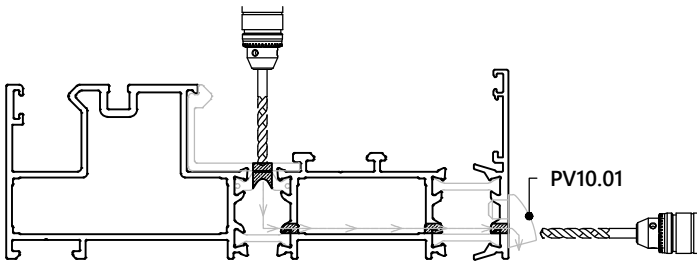

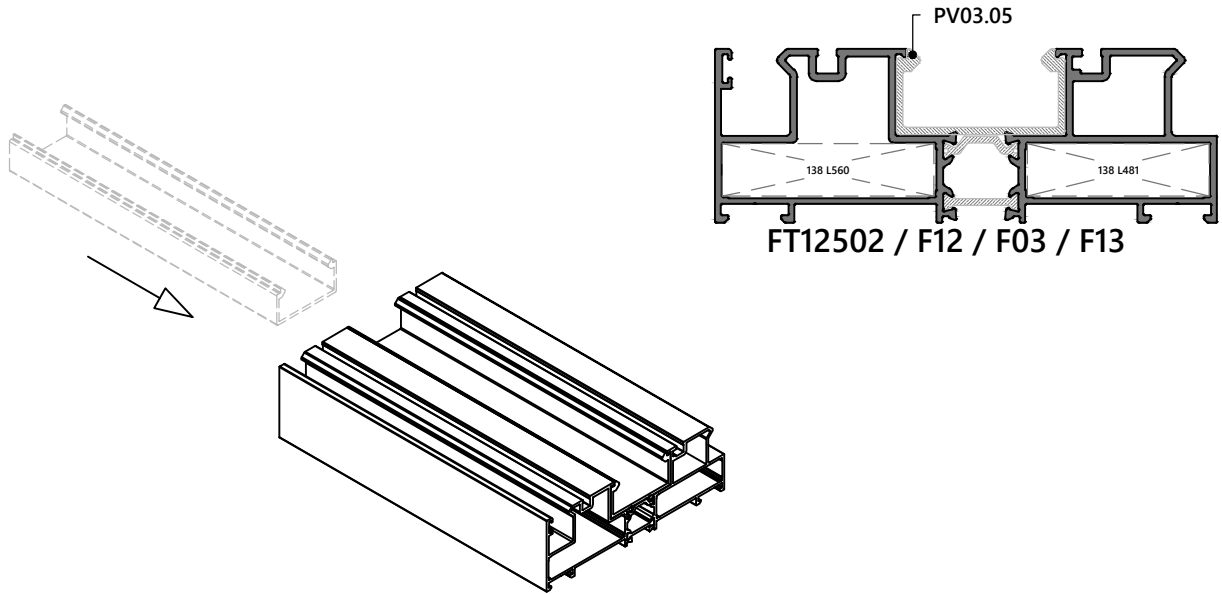

PV03.05 PVC KASA IZALOTÖRÜ FT12502 , F12 , F03 , F13

KASA Profilleri miktarı kadar olmalıdır. FT12503 ve F13 için mikar 2 katıdır.

Örneğin; FT12503 ve F13 profilleri için gereken miktar 1 Boy ise PV03.05 12 metre olarak hesaplanmalıdır.

İmalat aşamasında, birlikte kesimleri yapılmalıdır.

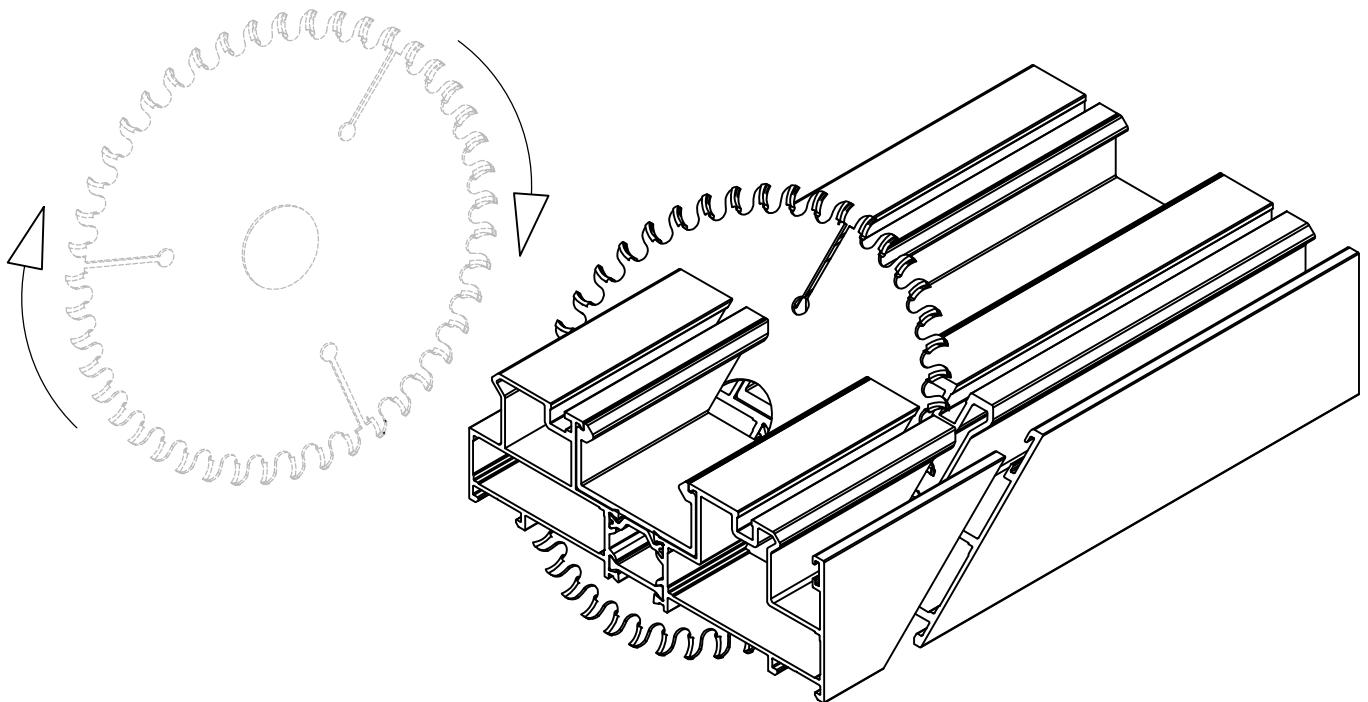

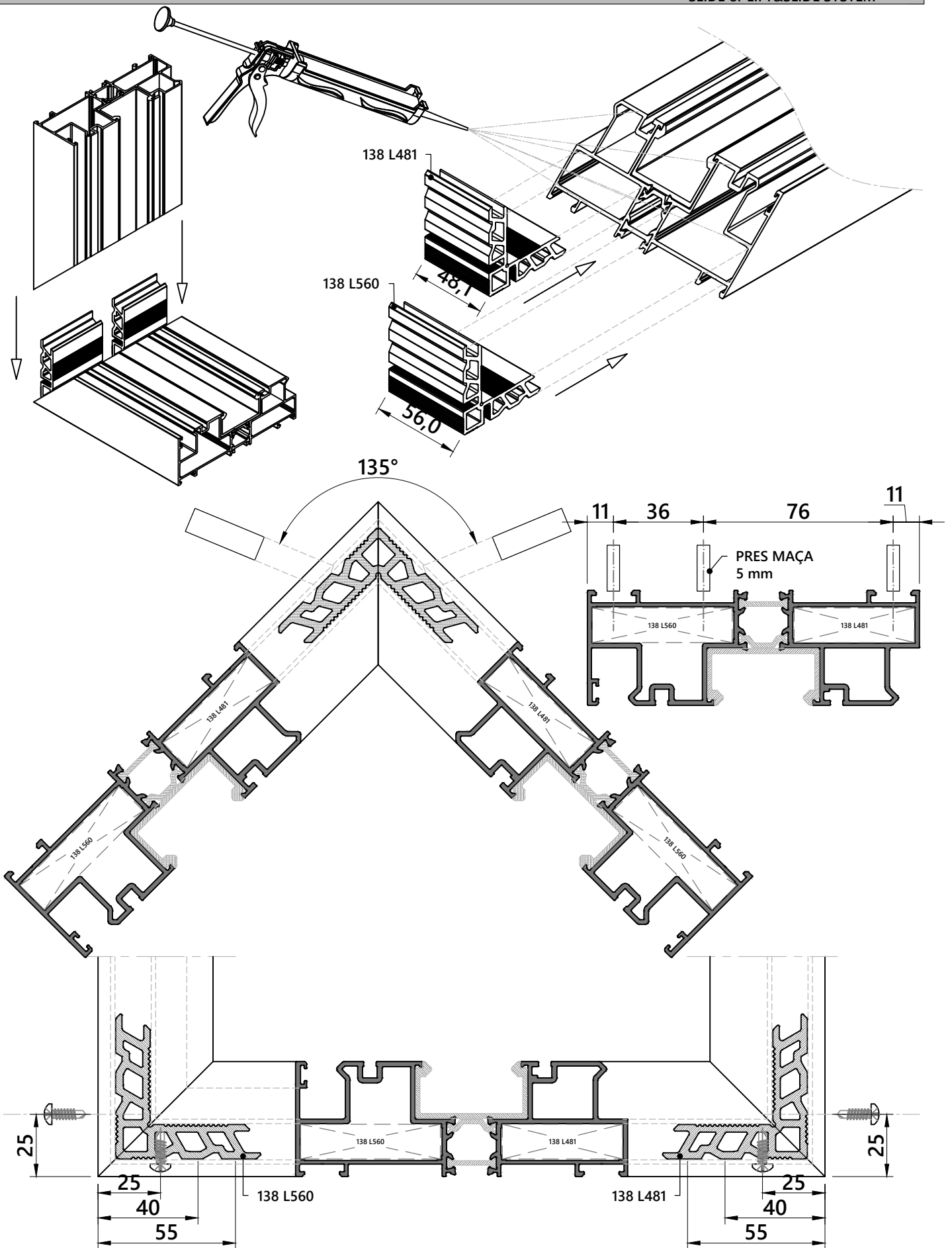

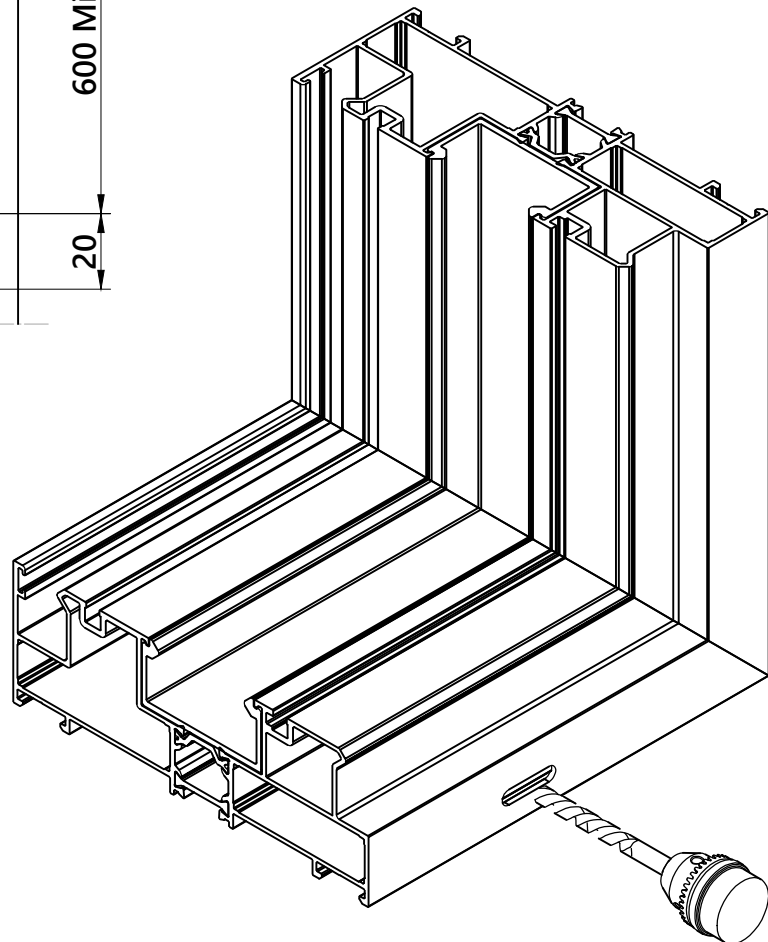
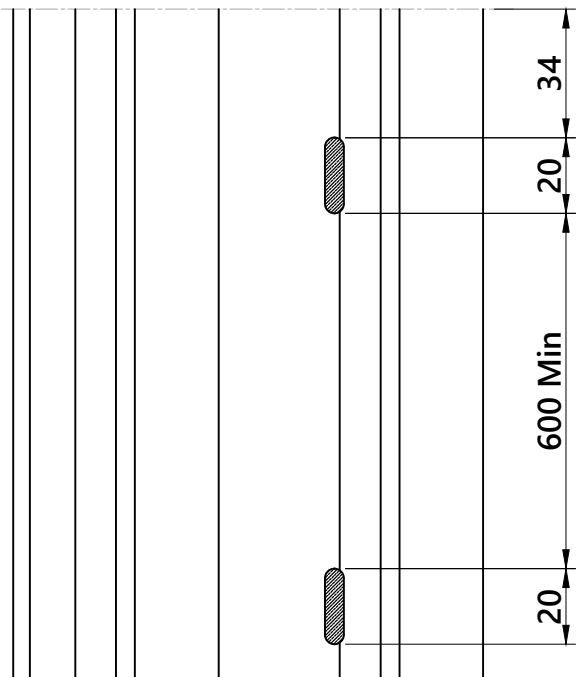
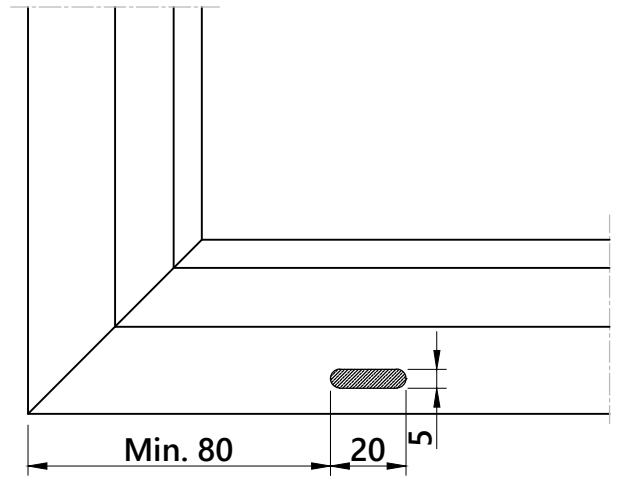
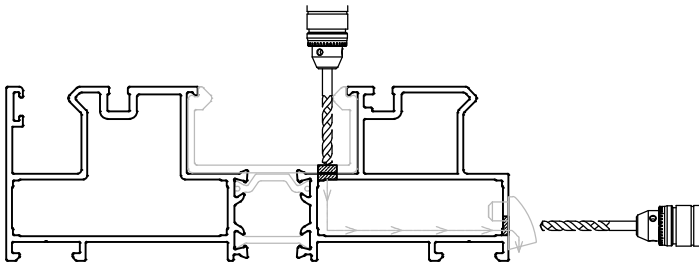

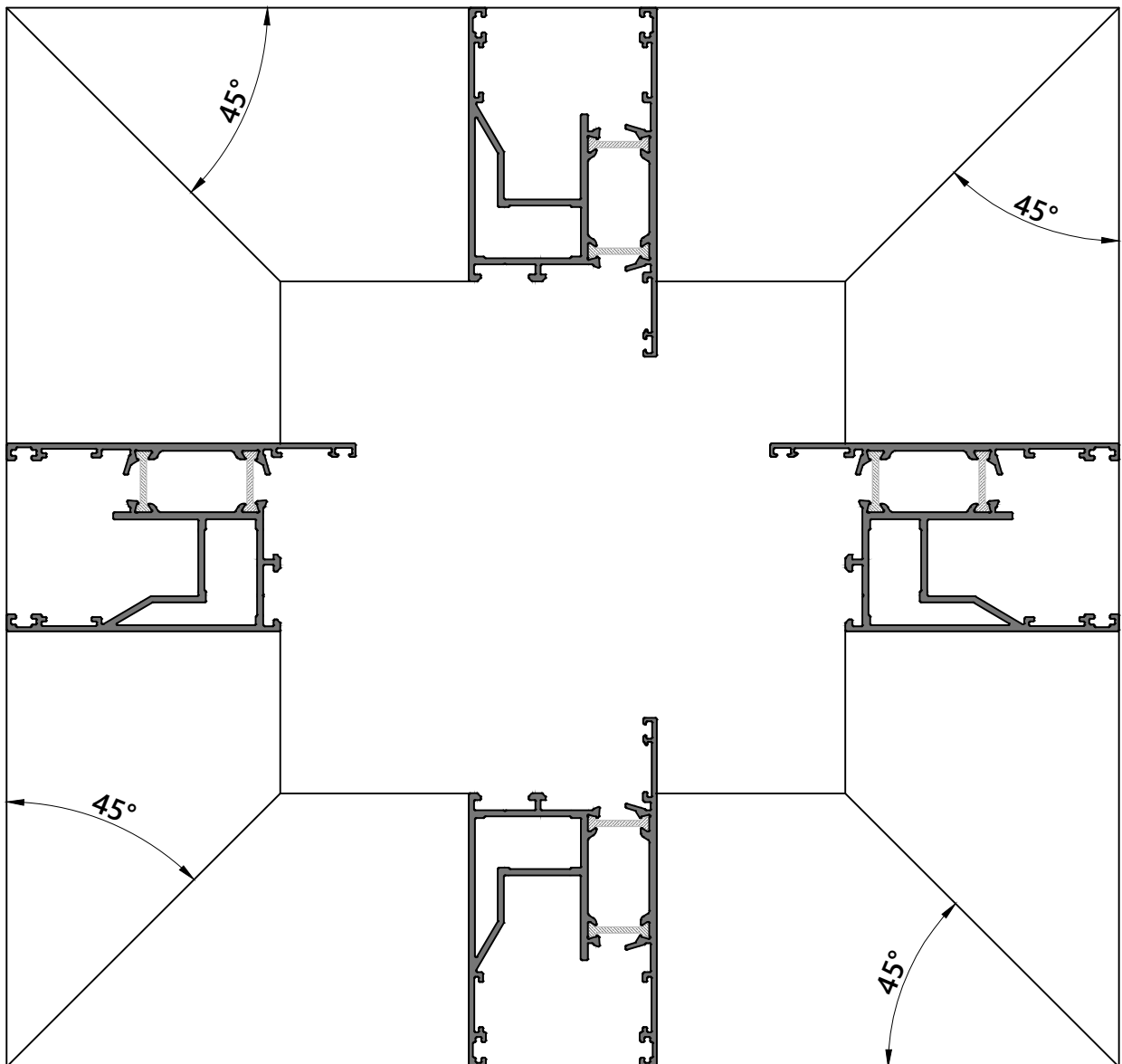
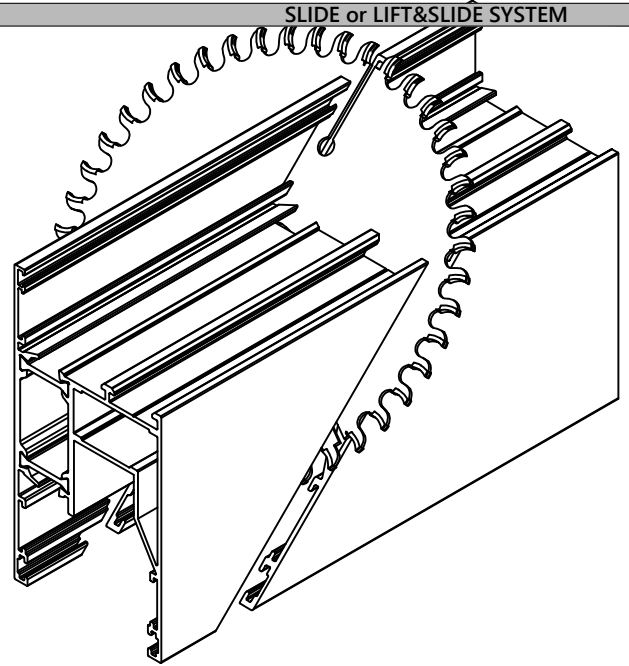
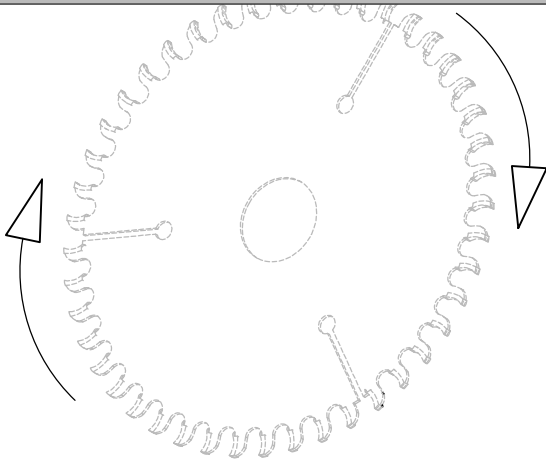

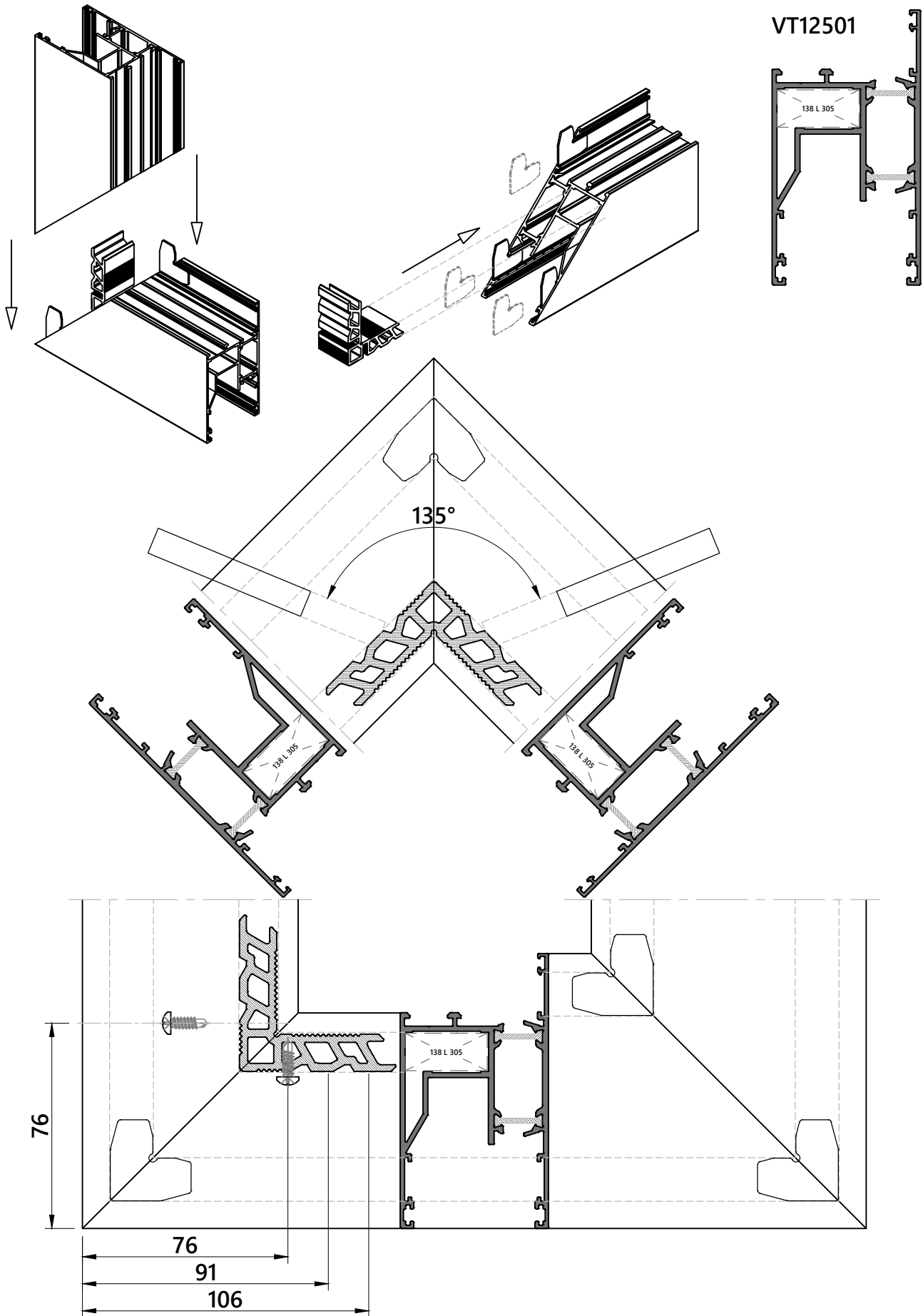

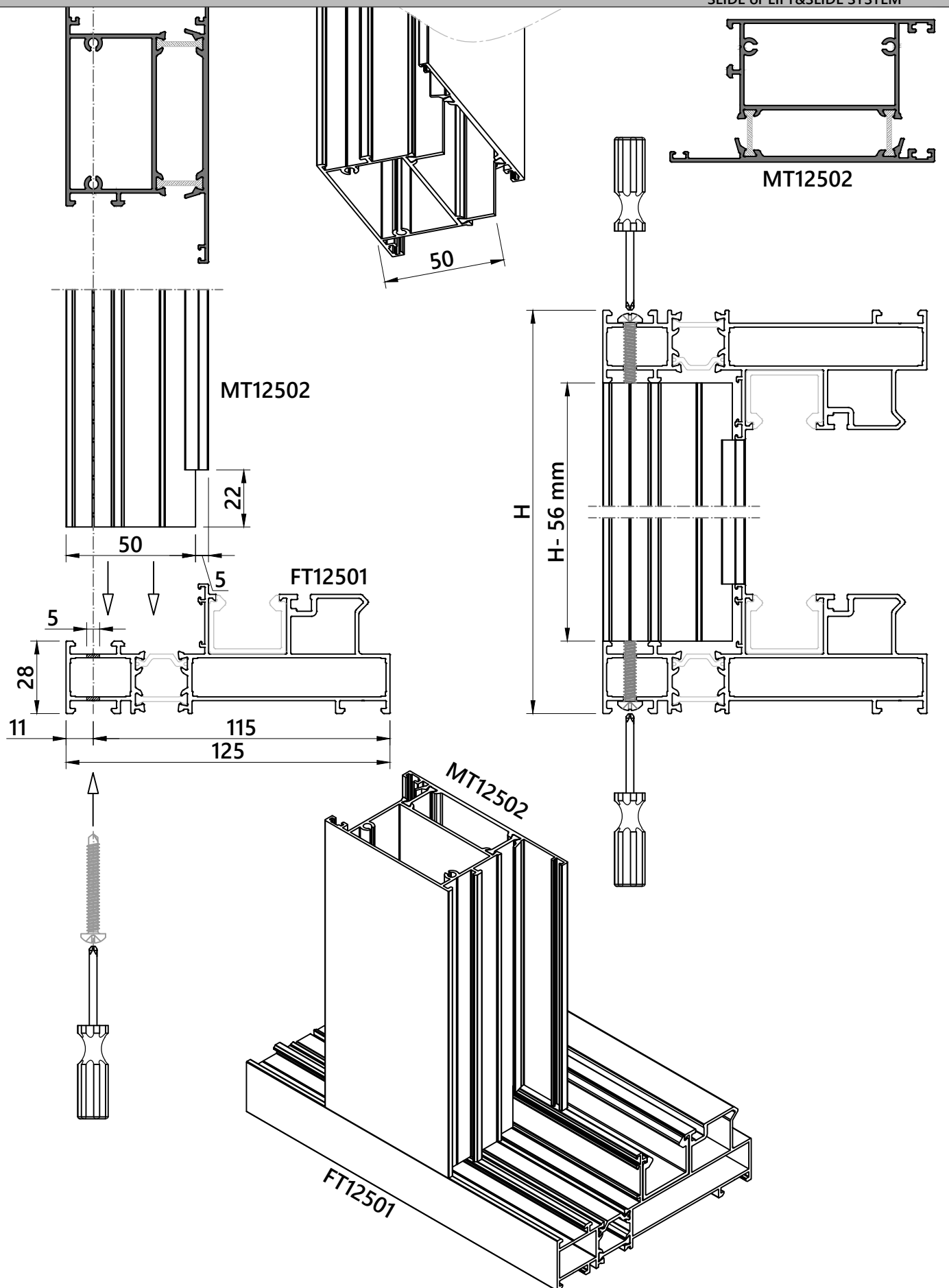

SLIDE or LIFT&SLIDE SYSTEM

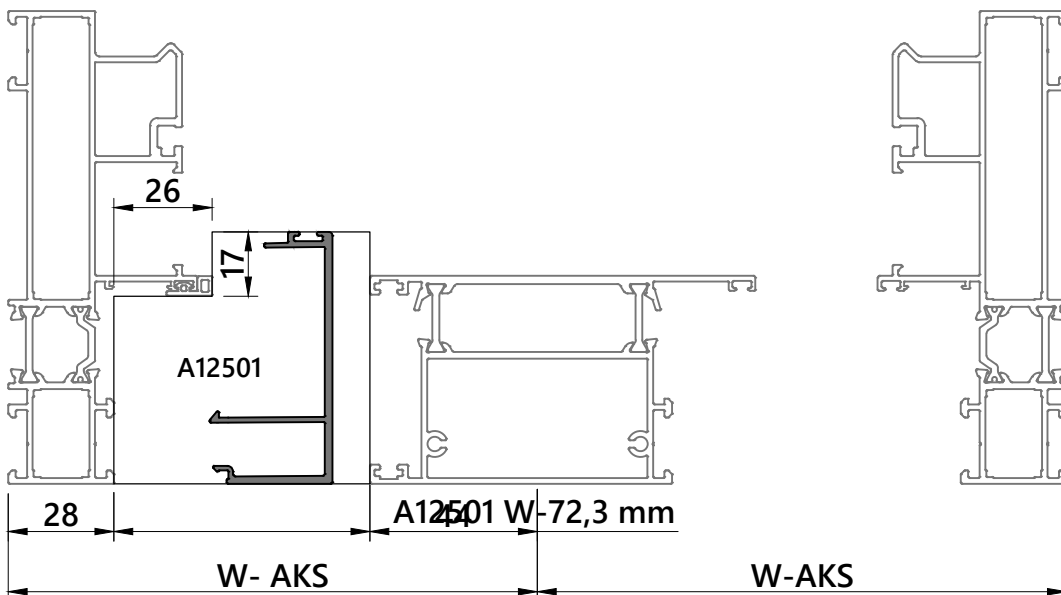
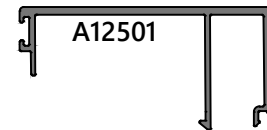
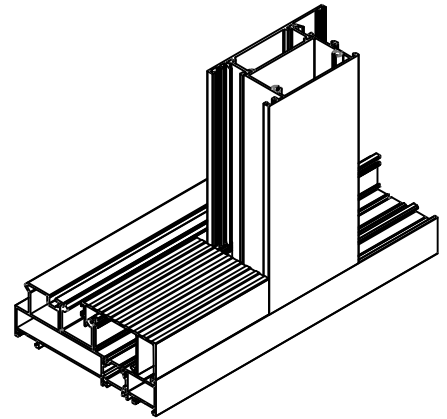
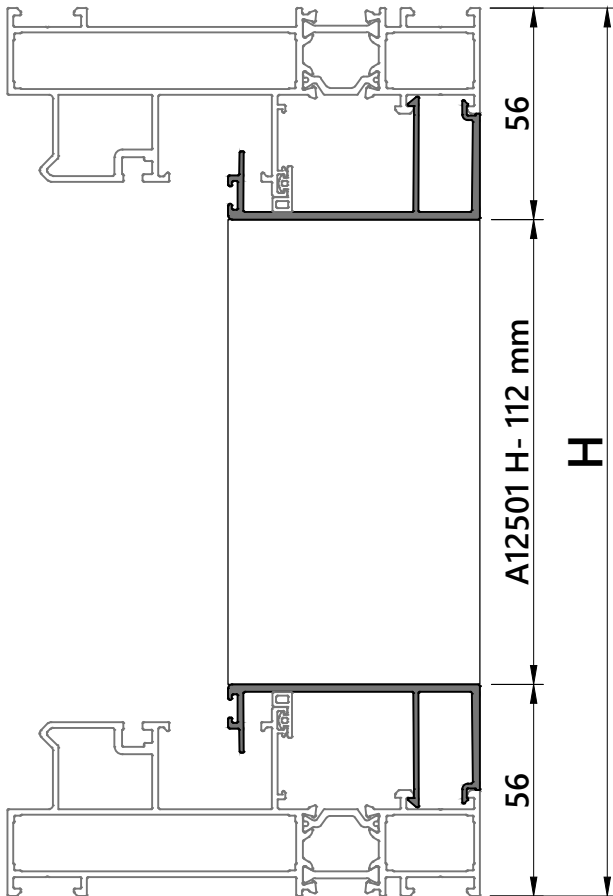
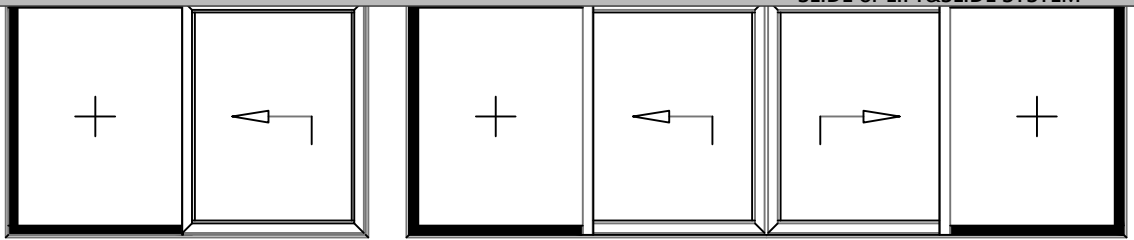

SLIDE or LIFT&SLIDE SYSTEM

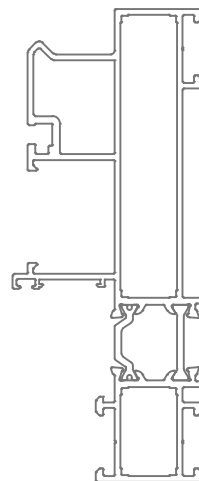
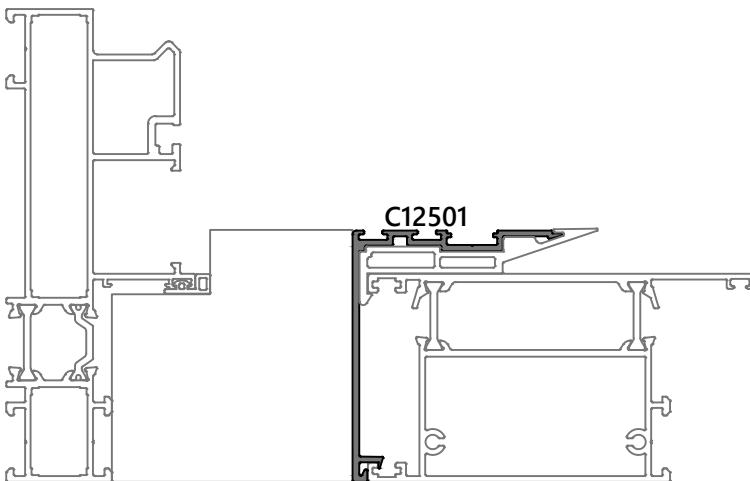
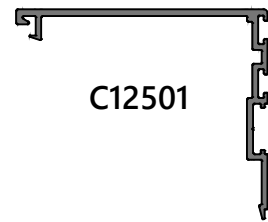
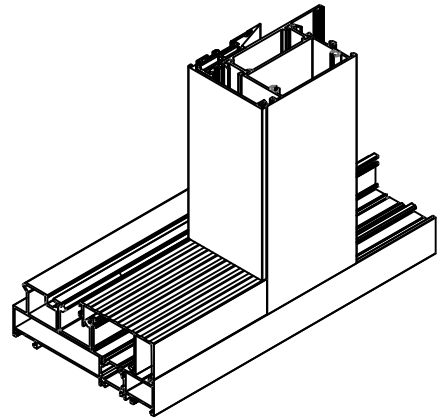
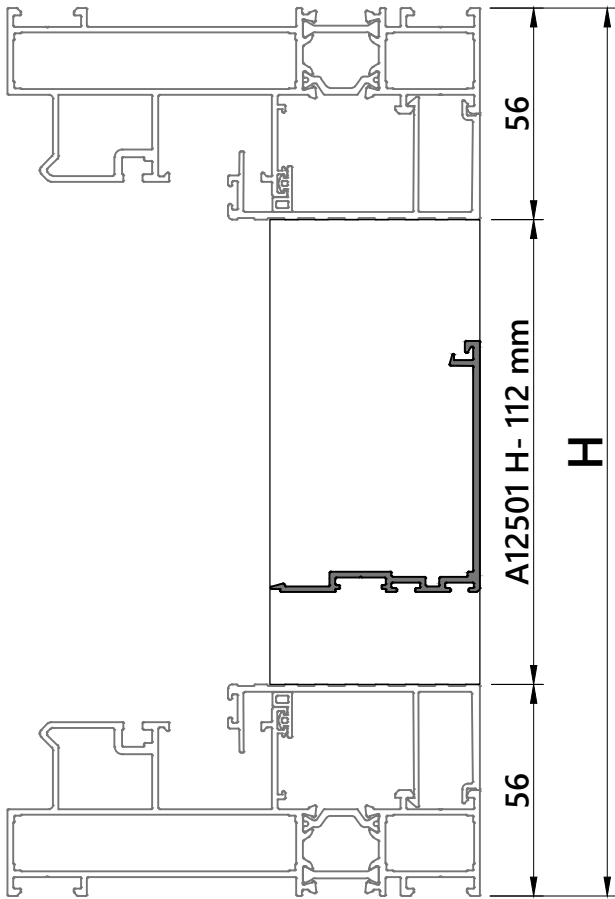
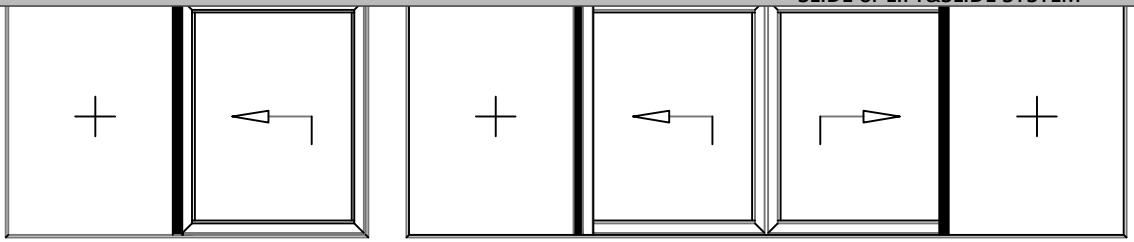

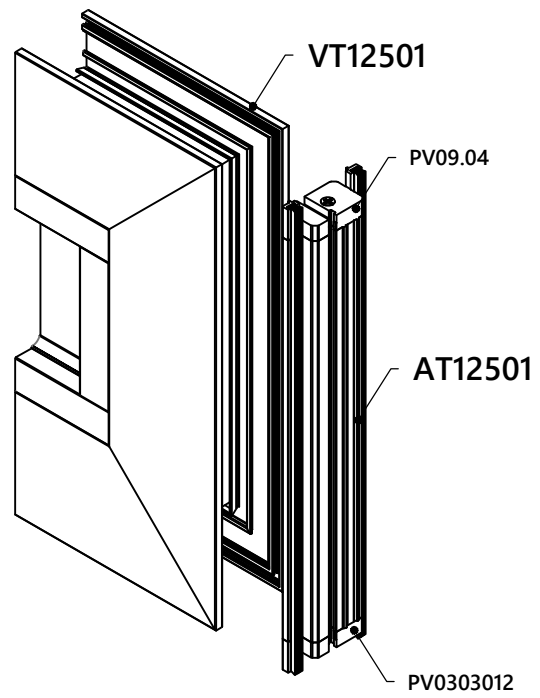
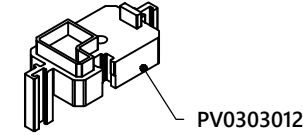
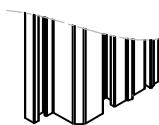
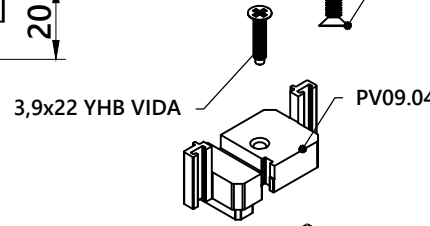
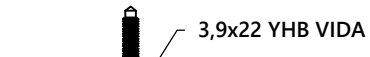
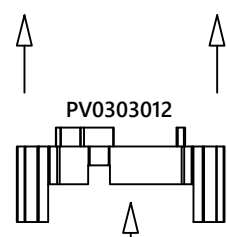
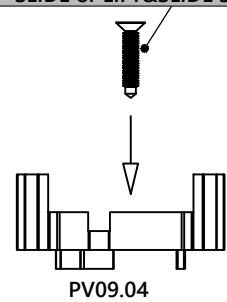
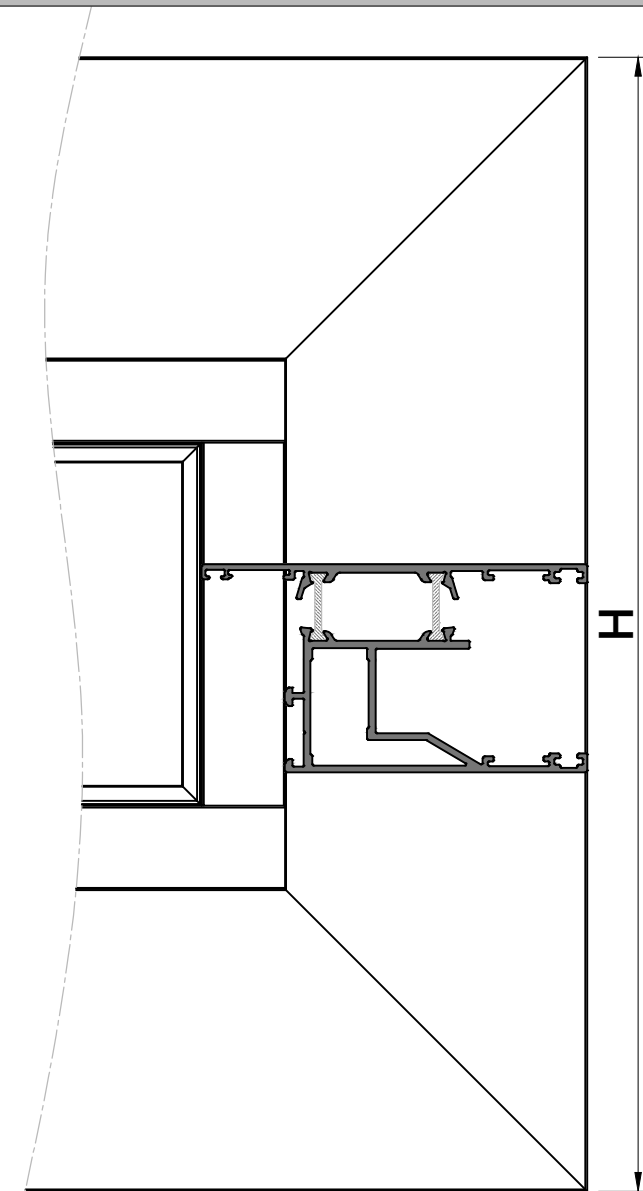

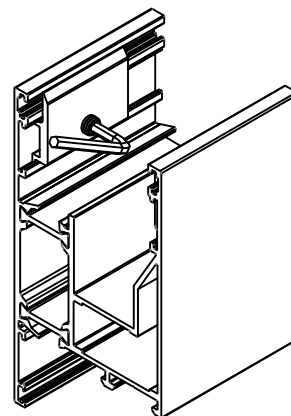
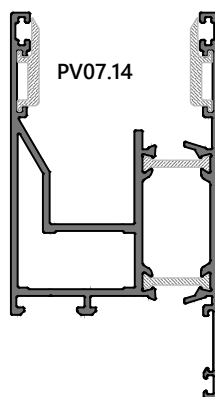
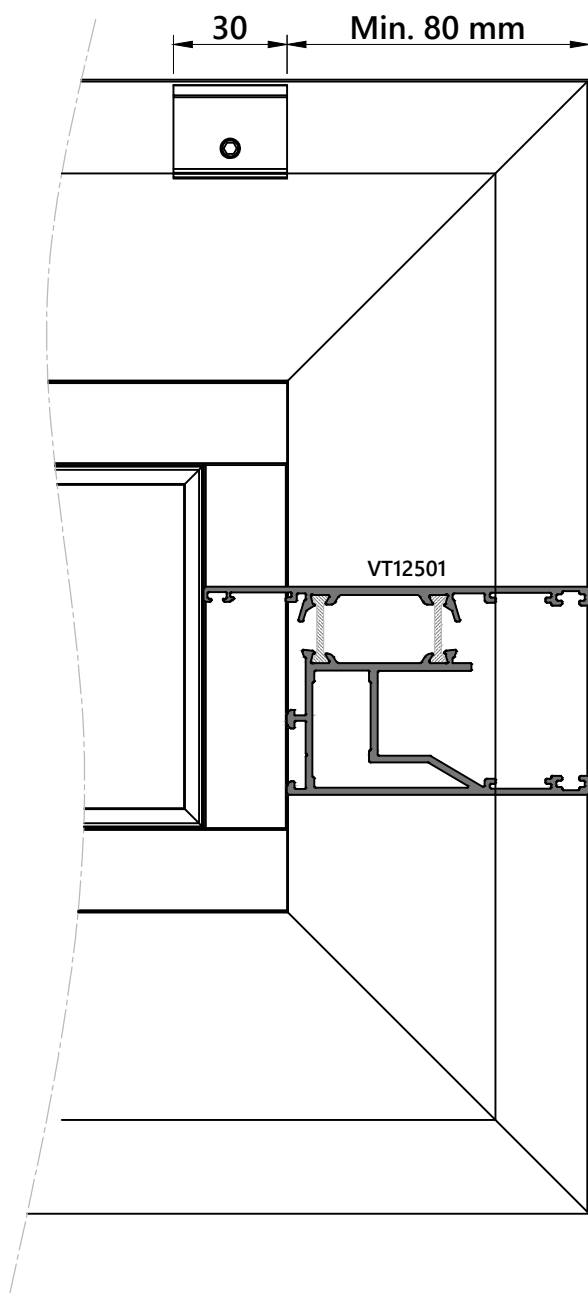
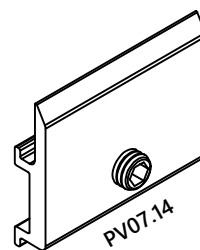

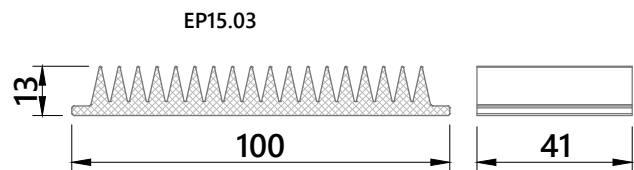
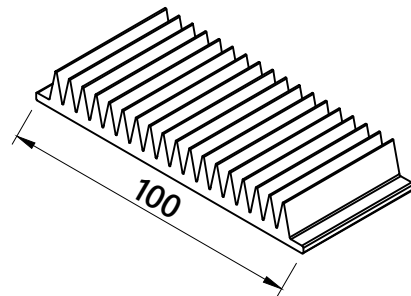
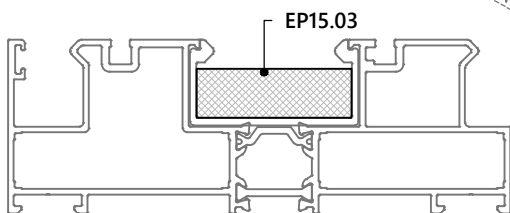
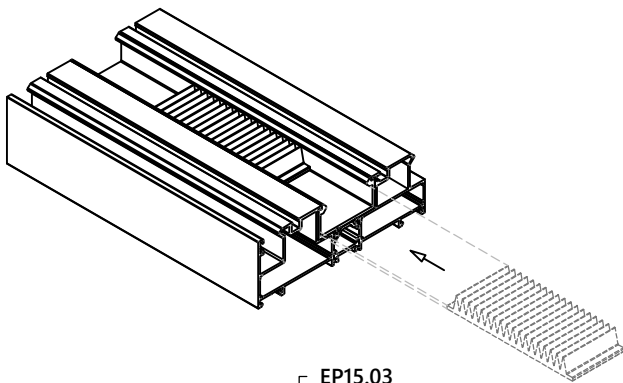
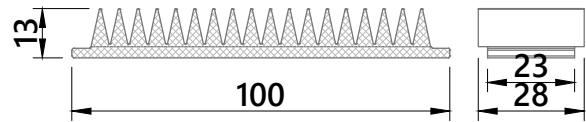
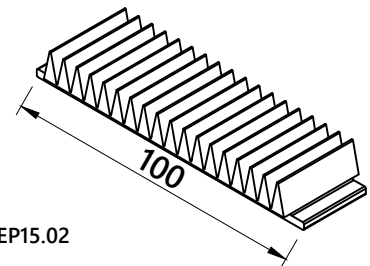
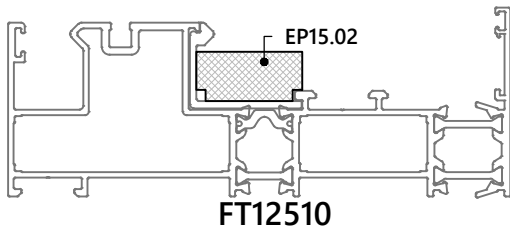
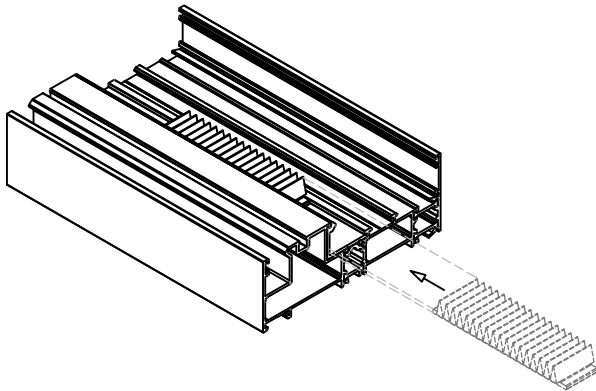
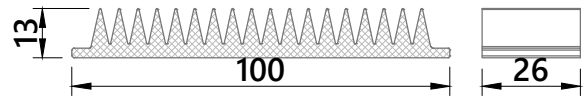
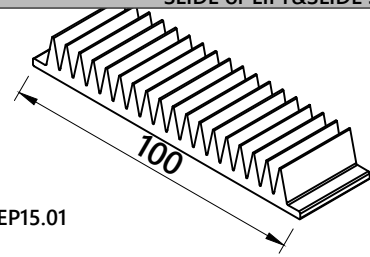
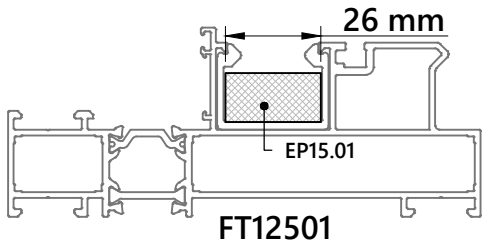
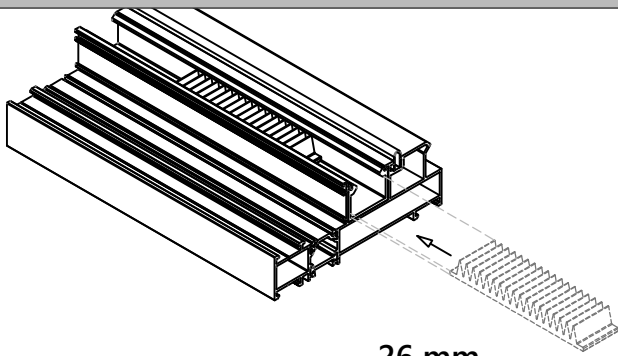

C12501

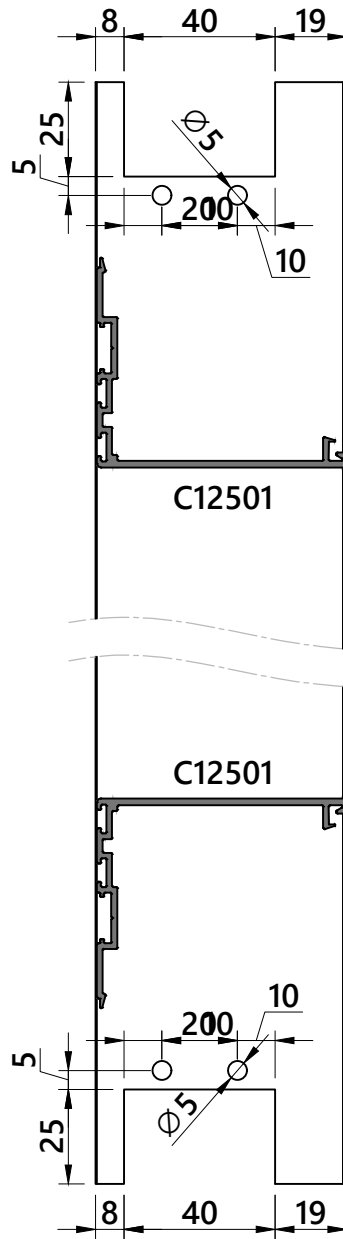
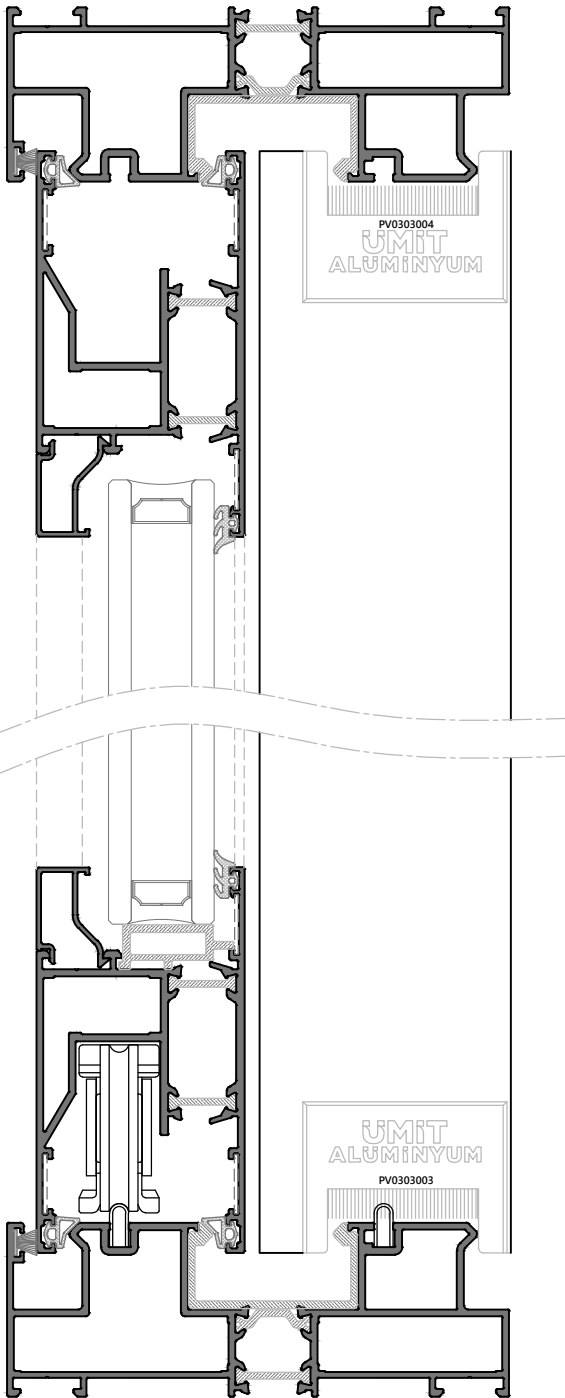
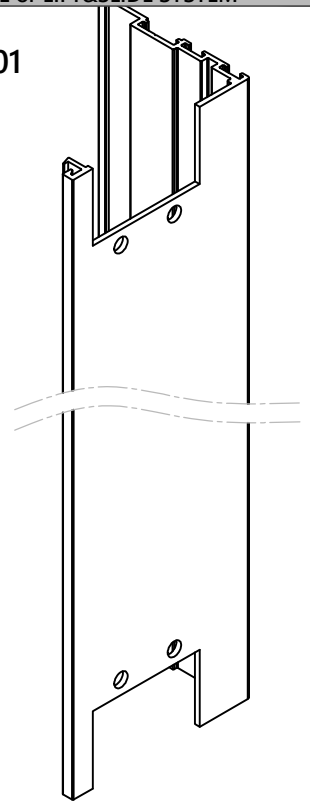

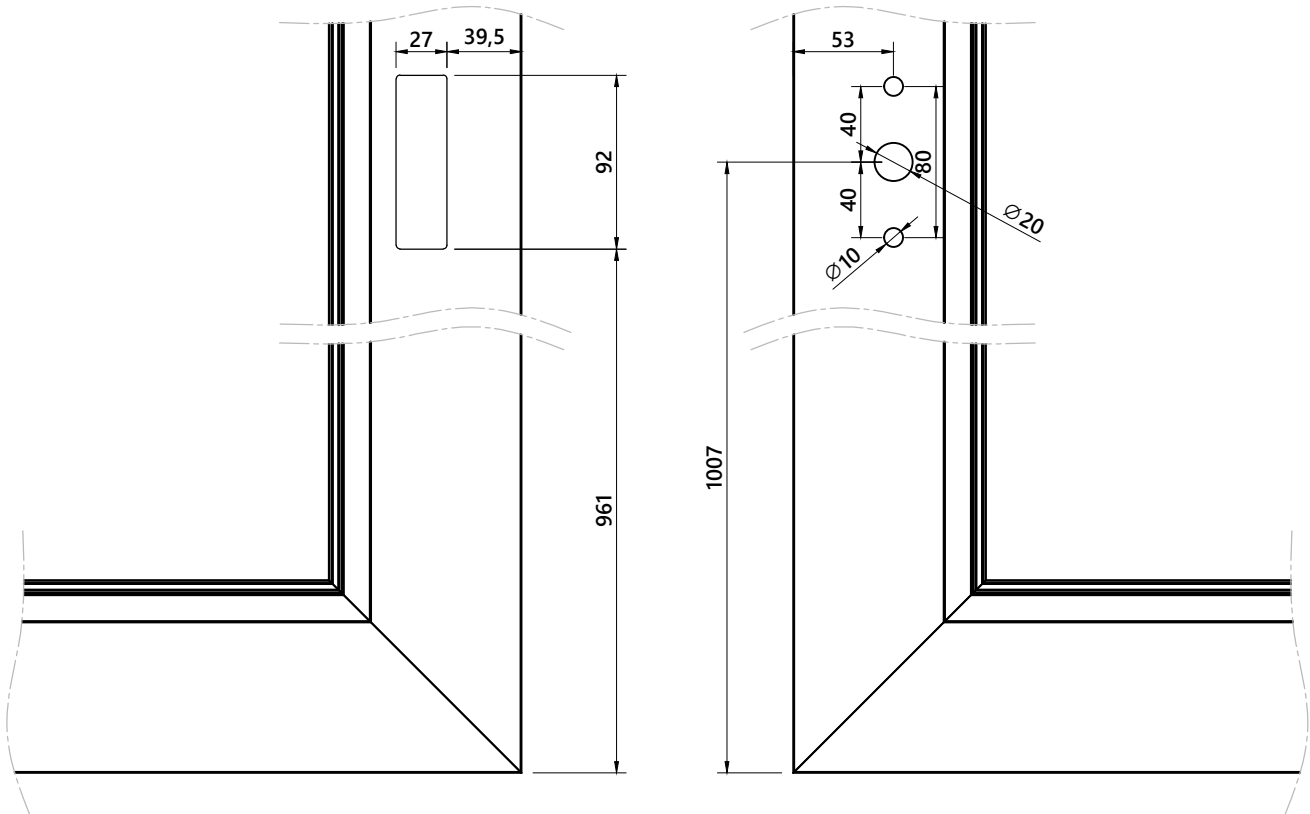
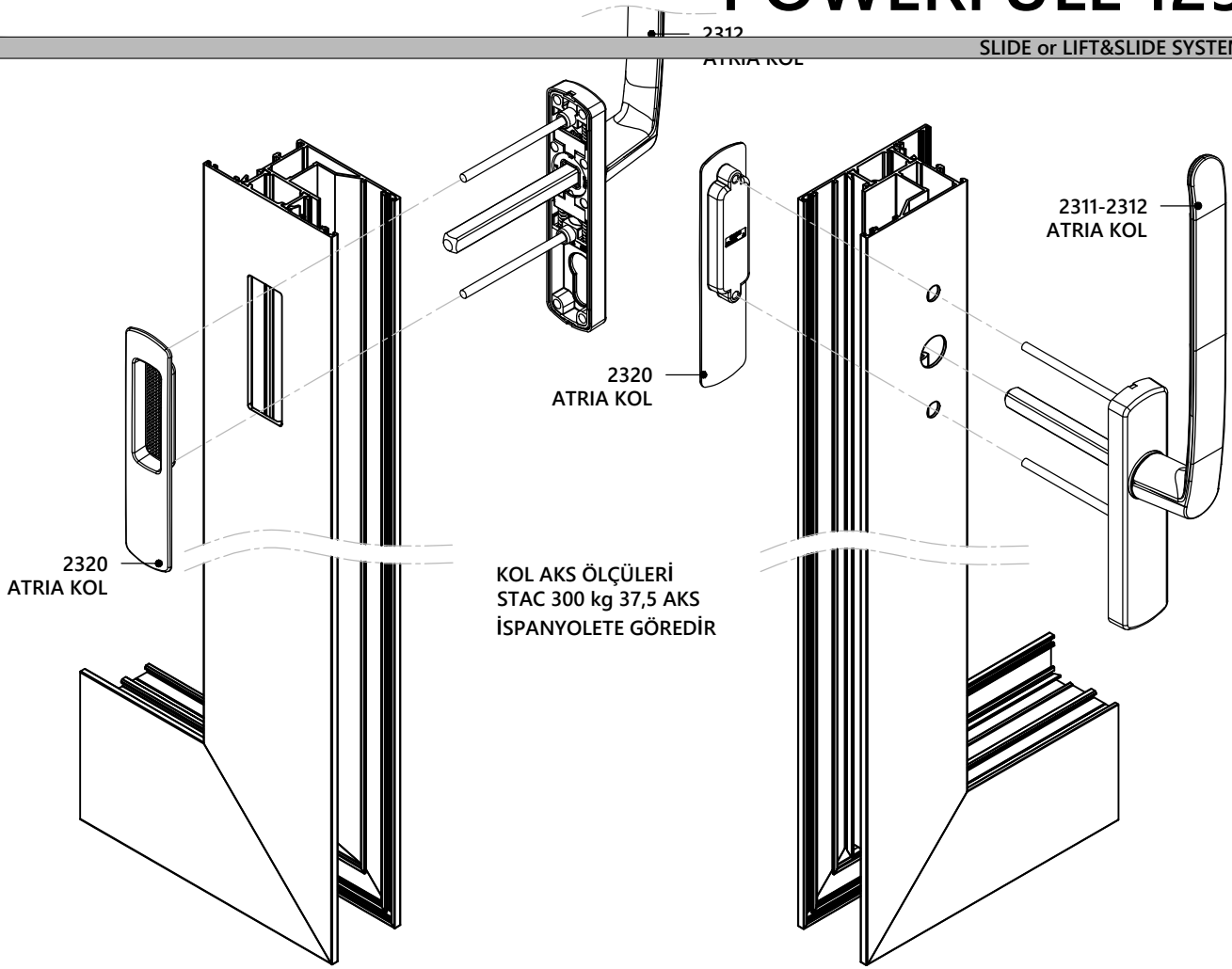

KESİM /İMALAT ÖLÇÜLERİ

MANUFACTURING DIMENSIONS

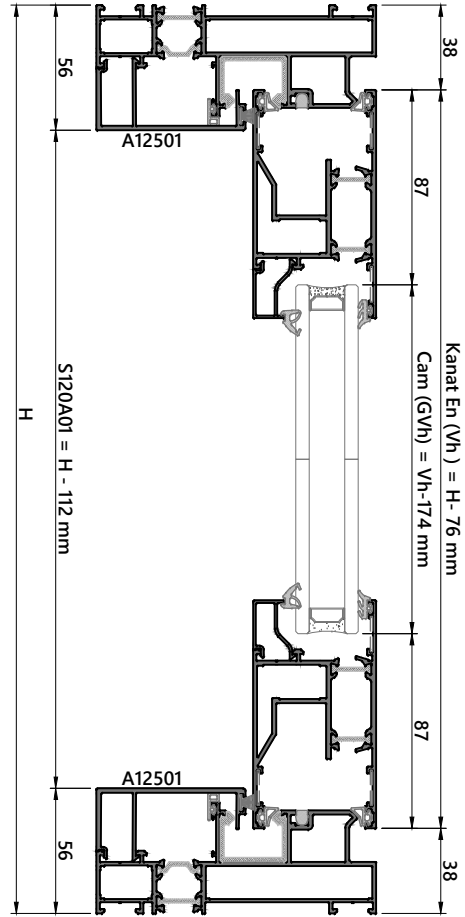

PROFİL KOD Profile Code	AÇIKLAMA Explanation	KESİM AÇISI Cut Angle	KESİM ÖLÇÜSÜ Cut Size	
			GENİŞLİK Weight	YÜKSEKLİK Height
FT12501 / F11	Kasa Profili	45° - 45°	W	H
VT12501	Kanat Profili	45° - 45°	$(W/2 - 38) + 94,5$	H - 76 mm
A12501	Ray Kapak Profili	90° - 90°	X - 68 mm	H - 112 mm
C12501	Kenet Profili (Sabit)	90° - 90°	-	H - 112 mm
C12501	Kenet Profili (Kanat)	90° - 90°	-	H - 76 mm
25 G **	Çıta Profili (Kanat)	90° - 90°	Vw-160 mm	Vh-204 mm
25 G **	Çıta Profili (Sabit)	90° - 90°	Y - 68 mm	H - 100 mm
	Cam (Kanat)	90° - 90°	Vw-174 mm	Vh-174 mm
	Cam (Sabit)	90° - 90°	Y - 82	H - 70 mm

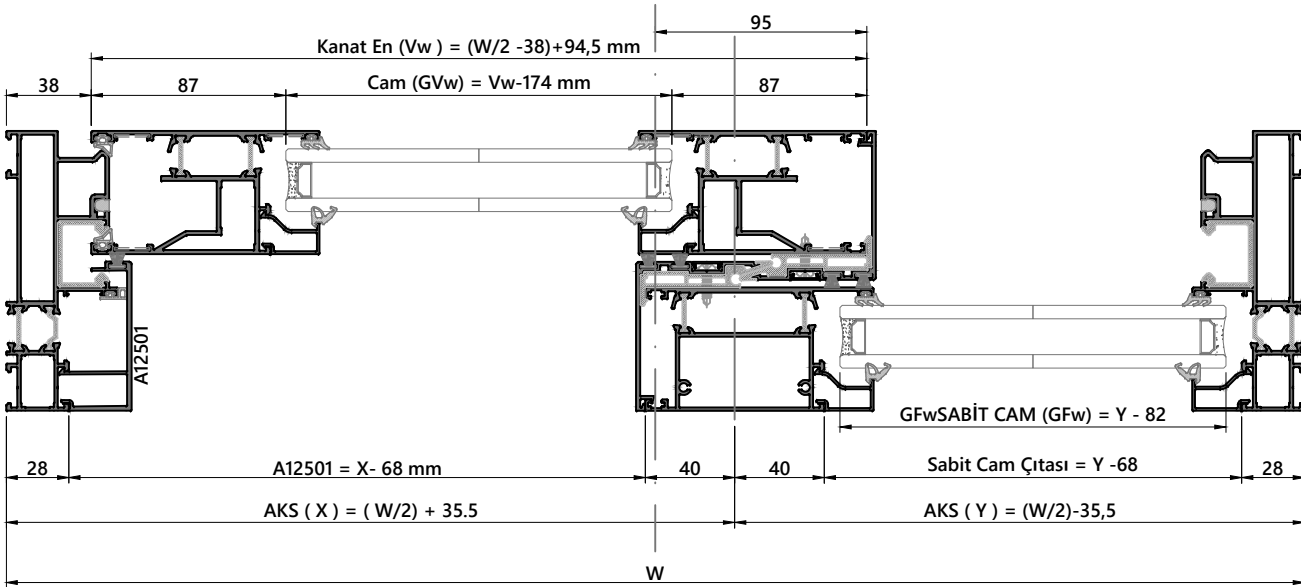
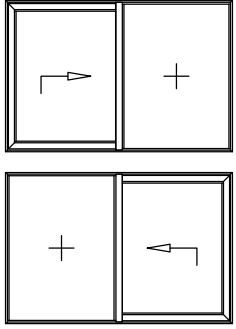

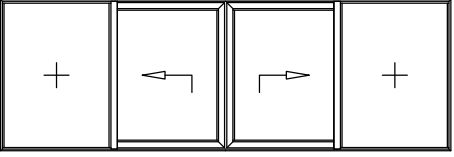

PROFİL KOD Profile Code	AÇIKLAMA Explanation	KESİM AÇISI Cut Angle	KESİM ÖLÇÜSÜ Cut Size	
			GENİŞLİK Weight	YÜKSEKLİK Height
FT12501 / F11	Kasa Profili	45° - 45 °	W	H
VT12501	Kanat Profili	45° - 45 °	$((W/4)-4)+77.5$	H- 76 mm
A12501	Ray Kapak Profili	90° - 90 °	X- 43 mm	-
C12501	Kenet Profili (Sabit)	90° - 90 °	-	H- 112 mm
C12501	Kenet Profili (Kanat)	90° - 90 °	-	H- 76 mm
25 G **	Çıta Profili (Kanat)	90° - 90 °	Vw-160 mm	Vh-204 mm
25 G **	Çıta Profili (Sabit)	90° - 90 °	Y - 86,5mm	H- 100 mm
	Cam (Kanat)	90° - 90 °	Vw-174 mm	Vh-174 mm
	Cam (Sabit)	90° - 90 °	Y-105	H - 70 mm

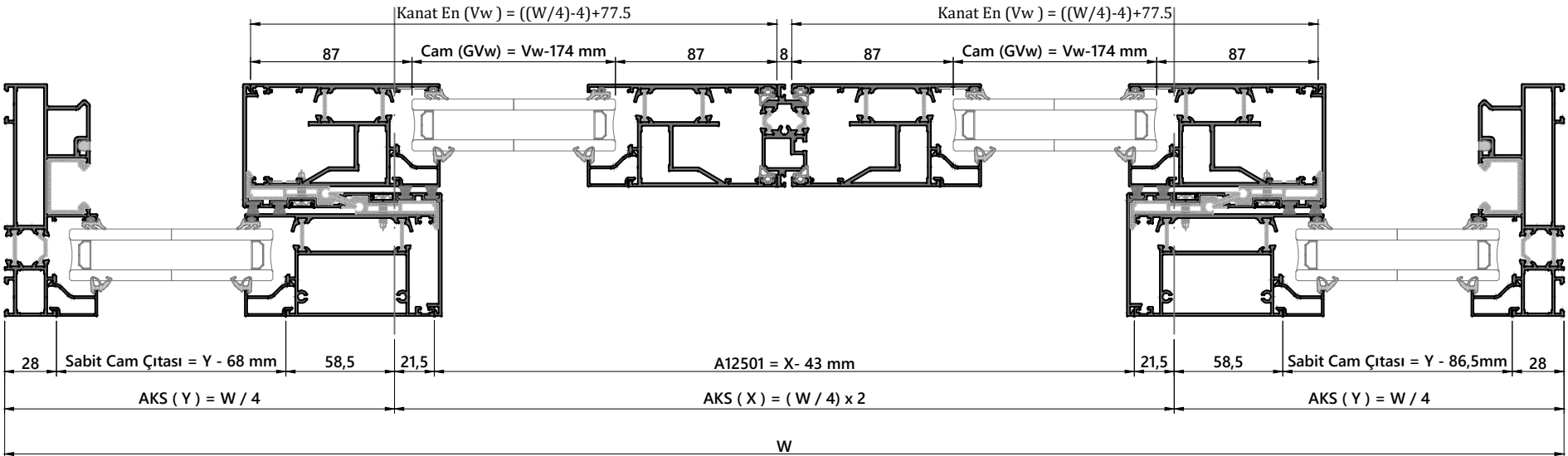
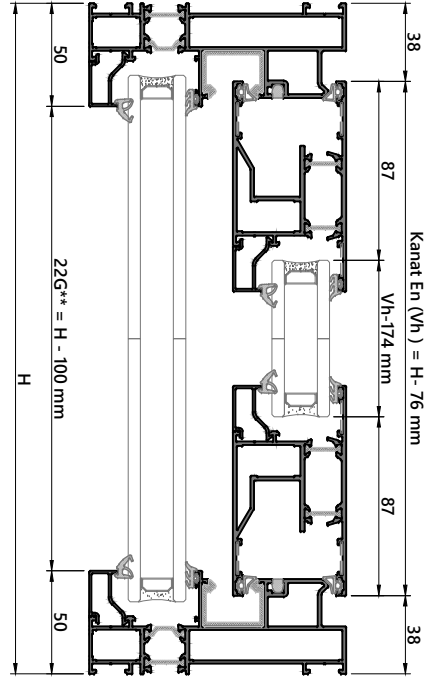

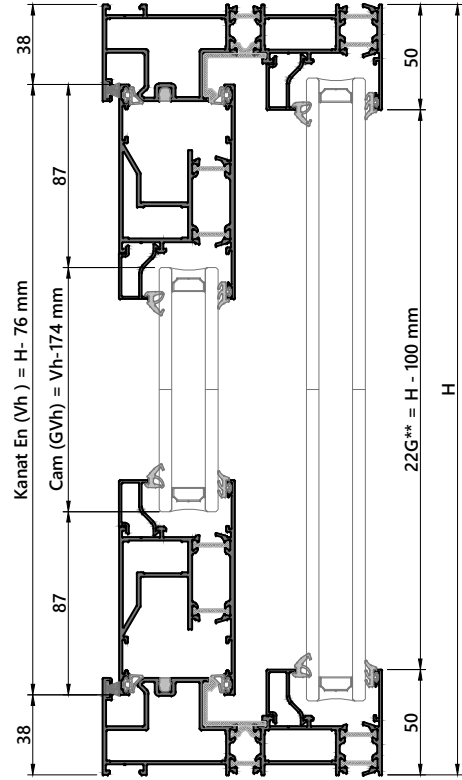

PROFİL KOD Profile Code	AÇIKLAMA Explanation	KESİM AÇISI Cut Angle	KESİM ÖLÇÜSÜ Cut Size	
			GENİŞLİK Weight	YÜKSEKLİK Height
FT12510	Kasa Profili	45° - 45°	W	H
VT12501	Kanat Profili	45° - 45°	$(W/2 - 38) + 94,5$	H - 76 mm
A12502	Ray Kapak Profili	90° - 90°	X-101 mm	H - 104 mm
C12501	Kenet Profili (Sabit)	90° - 90°	-	H - 104 mm
C12501	Kenet Profili (Kanat)	90° - 90°	-	H - 76 mm
25 G **	Çıta Profili (Kanat)	90° - 90°	Vw-160 mm	Vh-204 mm
25 G **	Çıta Profili (Sabit)	90° - 90°	Y - 57 mm	H - 100 mm
	Cam (Kanat)	90° - 90°	Vw-174 mm	Vh-174 mm
	Cam (Sabit)	90° - 90°	Y - 71 mm	H - 70 mm

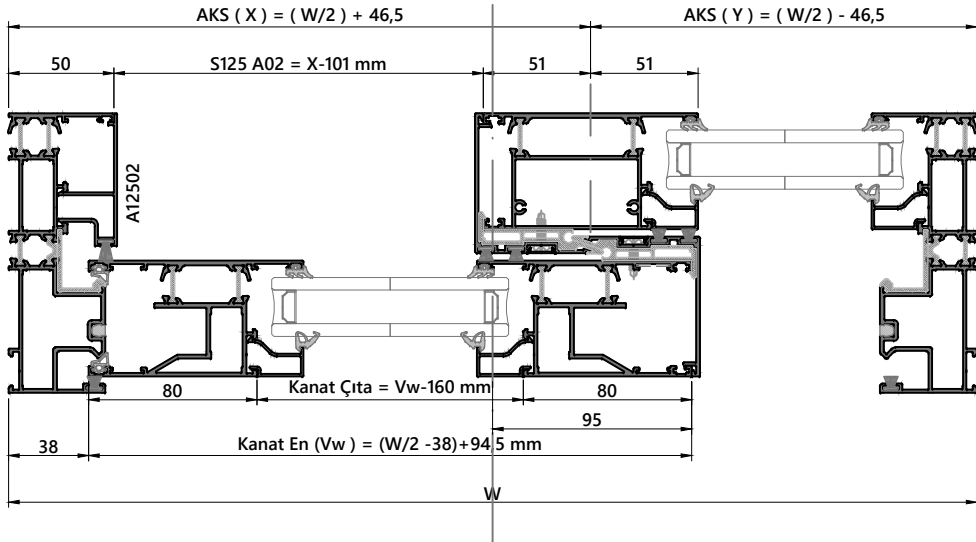
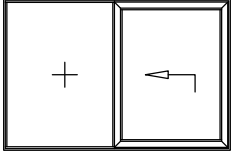
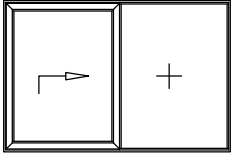

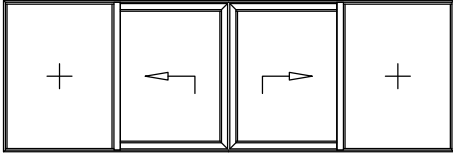

PROFİL KOD Profile Code	AÇIKLAMA Explanation	KESİM AÇISI Cut Angle	KESİM ÖLÇÜSÜ Cut Size	
			GENİŞLİK Weight	YÜKSEKLİK Height
FT12510	Kasa Profili	45° - 45°	W	H
VT12501	Kanat Profili	45° - 45°	$(W/4) - 4 + 77,5$	H - 76 mm
A12502	Ray Kapak Profili	90° - 90°	$(W/4) \times 2 - 43$	-
C12501	Kenet Profili (Sabit)	90° - 90°	-	H - 104 mm
C12501	Kenet Profili (Kanat)	90° - 90°	-	H - 76 mm
25 G **	Çıta Profili (Kanat)	90° - 90°	Vw-160 mm	Vh-204 mm
25 G **	Çıta Profili (Sabit)	90° - 90°	Y - 85 mm	H - 100 mm
	Cam (Kanat)	90° - 90°	Vw-174 mm	Vh-174 mm
	Cam (Sabit)	90° - 90°	Y - 72,5 mm	H - 70 mm

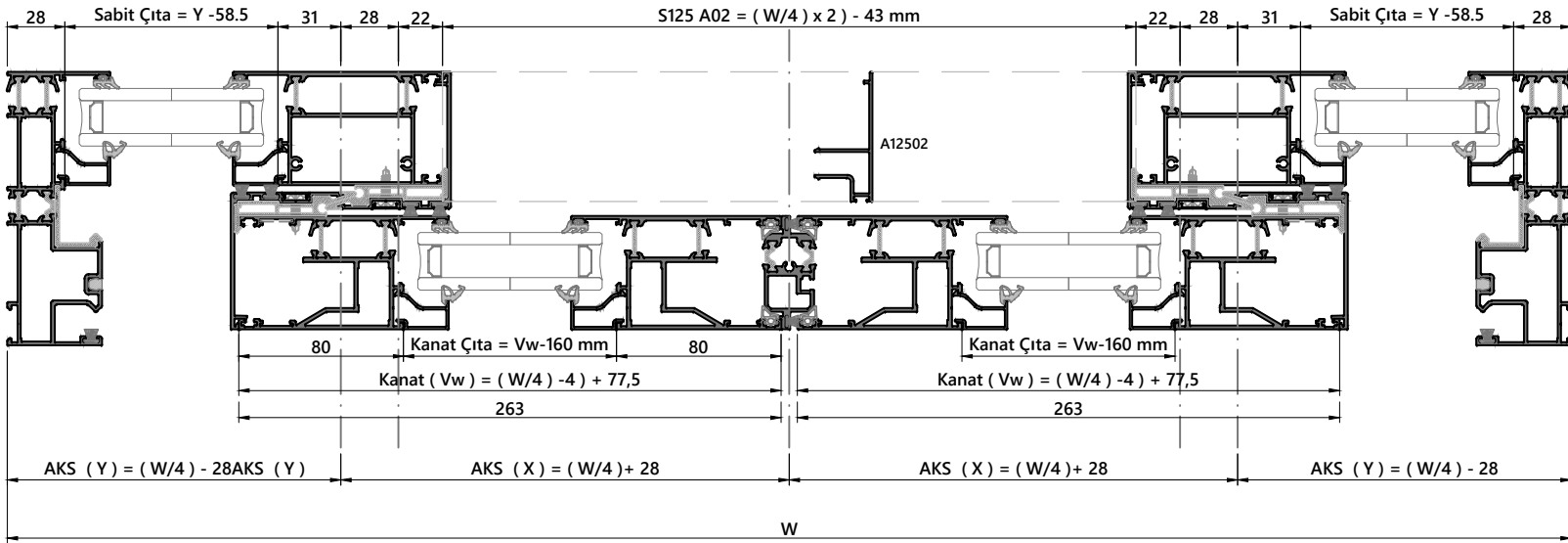
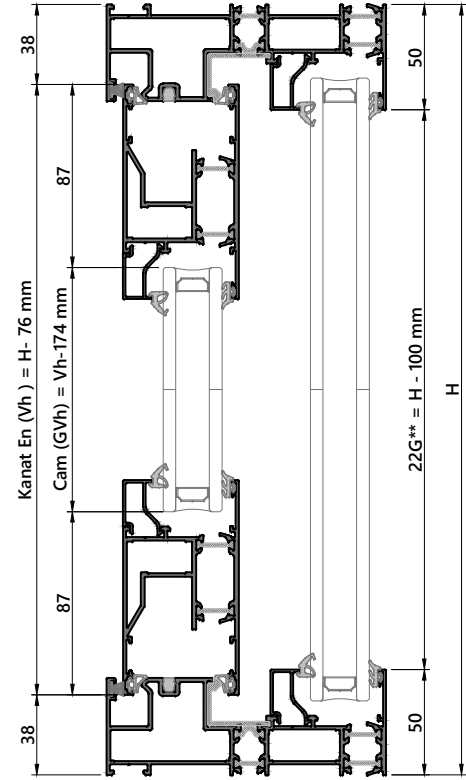

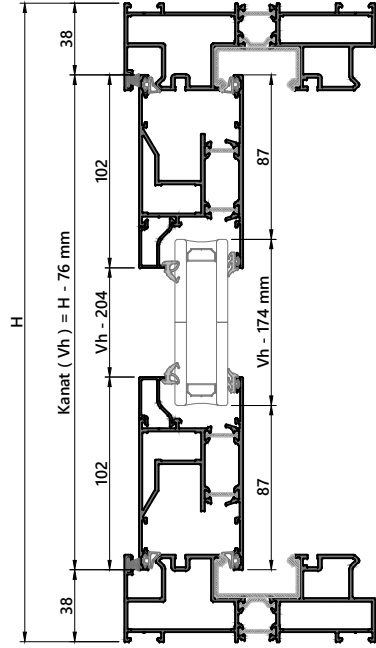

PROFİL KOD Profile Code	AÇIKLAMA Explanation	KESİM AÇISI Cut Angle	KESİM ÖLÇÜSÜ Cut Size	
			GENİŞLİK Weight	YÜKSEKLİK Height
FT12512 / F02	Kasa Profili	45° - 45°	W	H
VT12501	Kanat Profili	45° - 45°	(W/2) +12	H- 76 mm
C12501	Kenet Profili (Kanat)	90° - 90°	-	H- 76 mm
25 G **	Çita Profili (Kanat)	90° - 90°	Vw-160 mm	Vh-204 mm
	Cam (Kanat)	90° - 90°	Vw-174 mm	Vh-174 mm

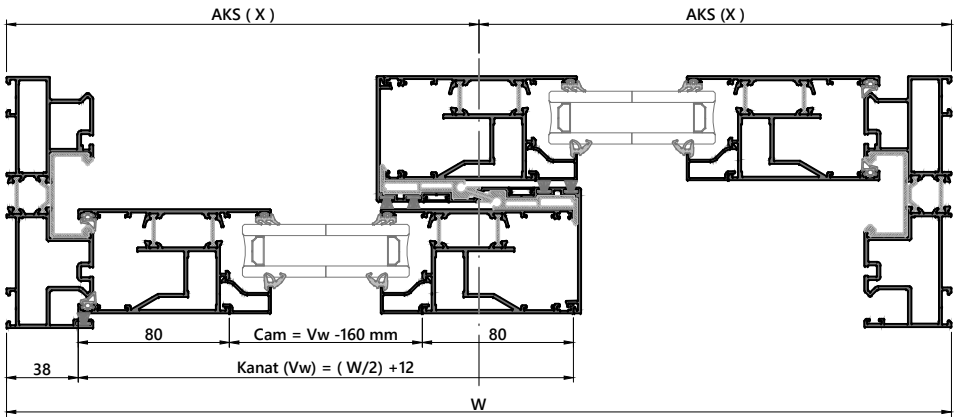
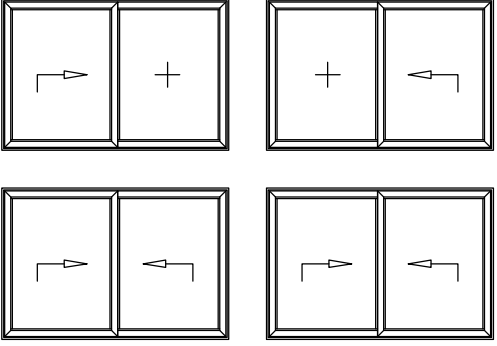

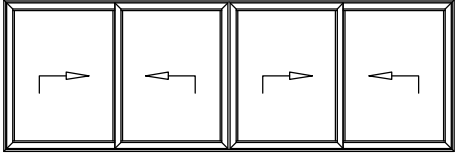
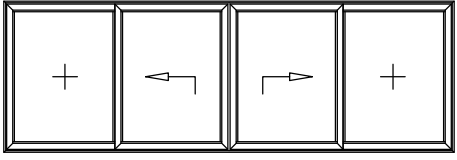

PROFİL KOD Profile Code	AÇIKLAMA Explanation	KESİM AÇISI Cut Angle	KESİM ÖLÇÜSÜ Cut Size	
			GENİŞLİK Weight	YÜKSEKLİK Height
FT12512 / F02	Kasa Profili	45° - 45°	W	H
VT12501	Kanat Profili	45° - 45°	$(W-84)/4+50$	H- 76 mm
C12501	Kenet Profili (Kanat)	90° - 90°	-	H- 76 mm
25 G **	Çita Profili (Kanat)	90° - 90°	Vw-160 mm	Vh-204 mm
	Cam (Kanat)	90° - 90°	Vw-174 mm	Vh-174 mm

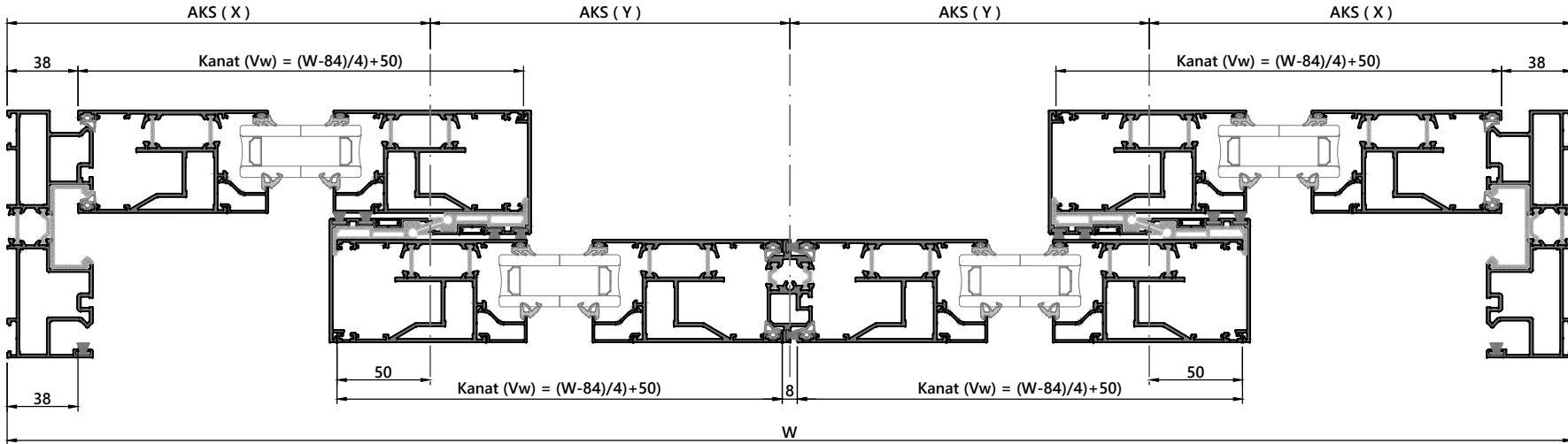
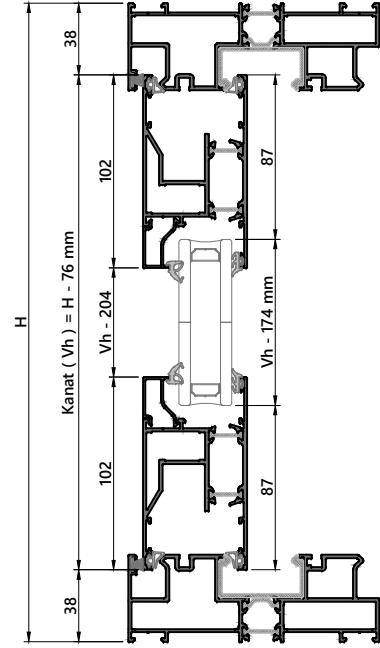

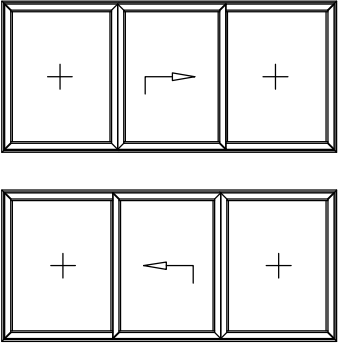

PROFİL KOD Profile Code	AÇIKLAMA Explanation	KESİM AÇISI Cut Angle	KESİM ÖLÇÜSÜ Cut Size	
			GENİŞLİK Weight	YÜKSEKLİK Height
FT12512 / F02	Kasa Profili	45° - 45°	W	H
VT12501	Kanat Profili	45° - 45°	$(W-84)/3+33$	H- 76 mm
C12501	Kenet Profili (Kanat)	90° - 90°	-	H- 76 mm
25 G **	Çita Profili (Kanat)	90° - 90°	Vw-160 mm	Vh-204 mm
	Cam (Kanat)	90° - 90°	Vw-174 mm	Vh-174 mm

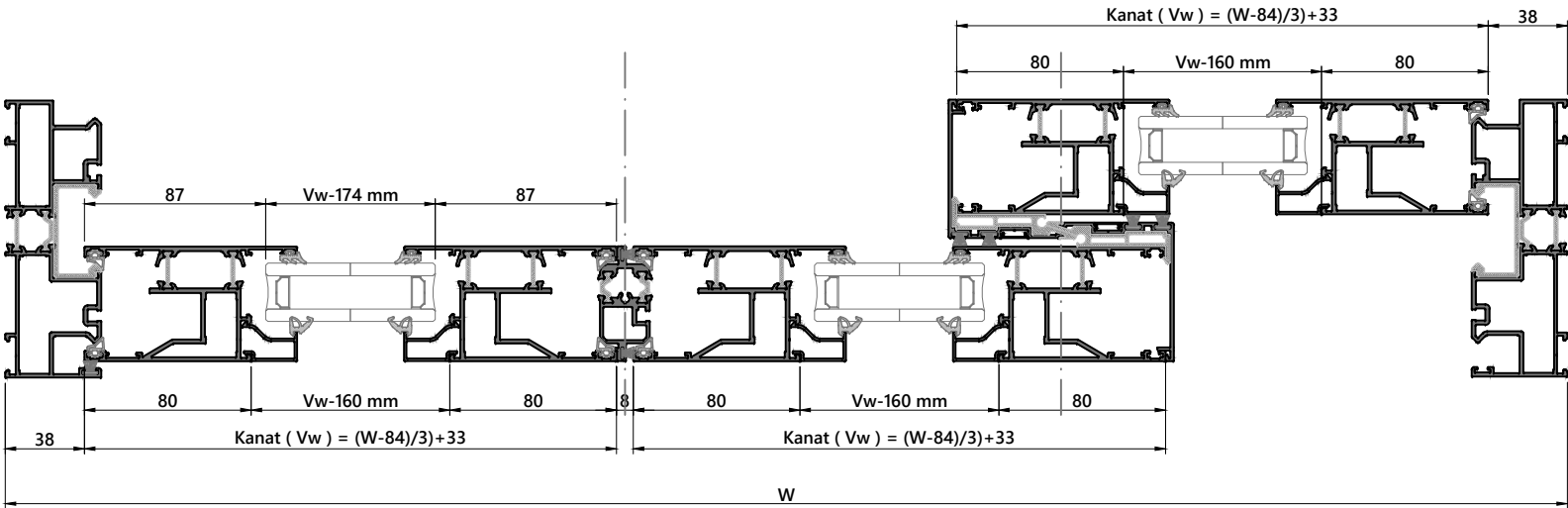
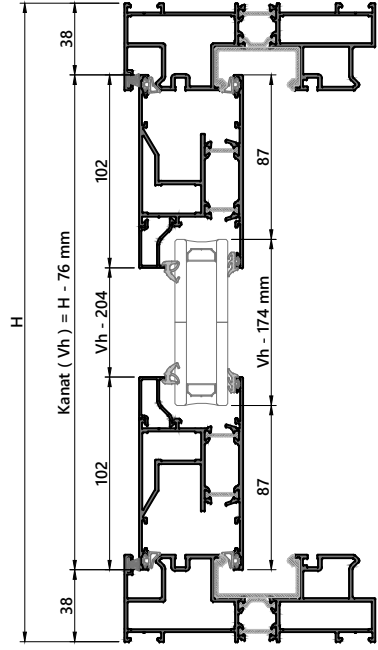

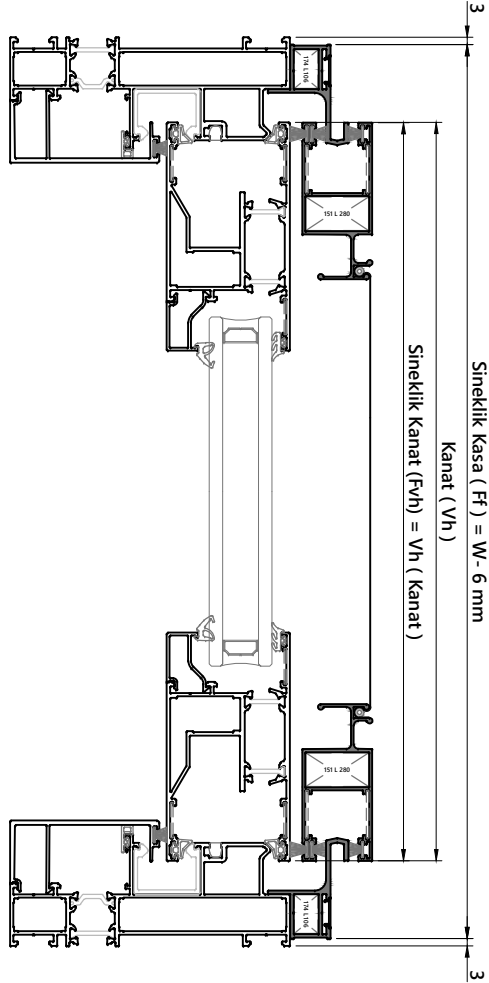

PROFİL KOD Profile Code	AÇIKLAMA Explanation	KESİM AÇISI Cut Angle	KESİM ÖLÇÜSÜ Cut Size	
			GENİŞLİK Weight	YÜKSEKLİK Height
S12502	Sineklik Kasa Profili	45° - 45°	W-6 mm	H - 6 mm
S12501	Sineklik Kanat Profili	45° - 45°	Vw	Vh
D12503	Vida Kapak Profili	45° - 45°	Ff-10 mm	

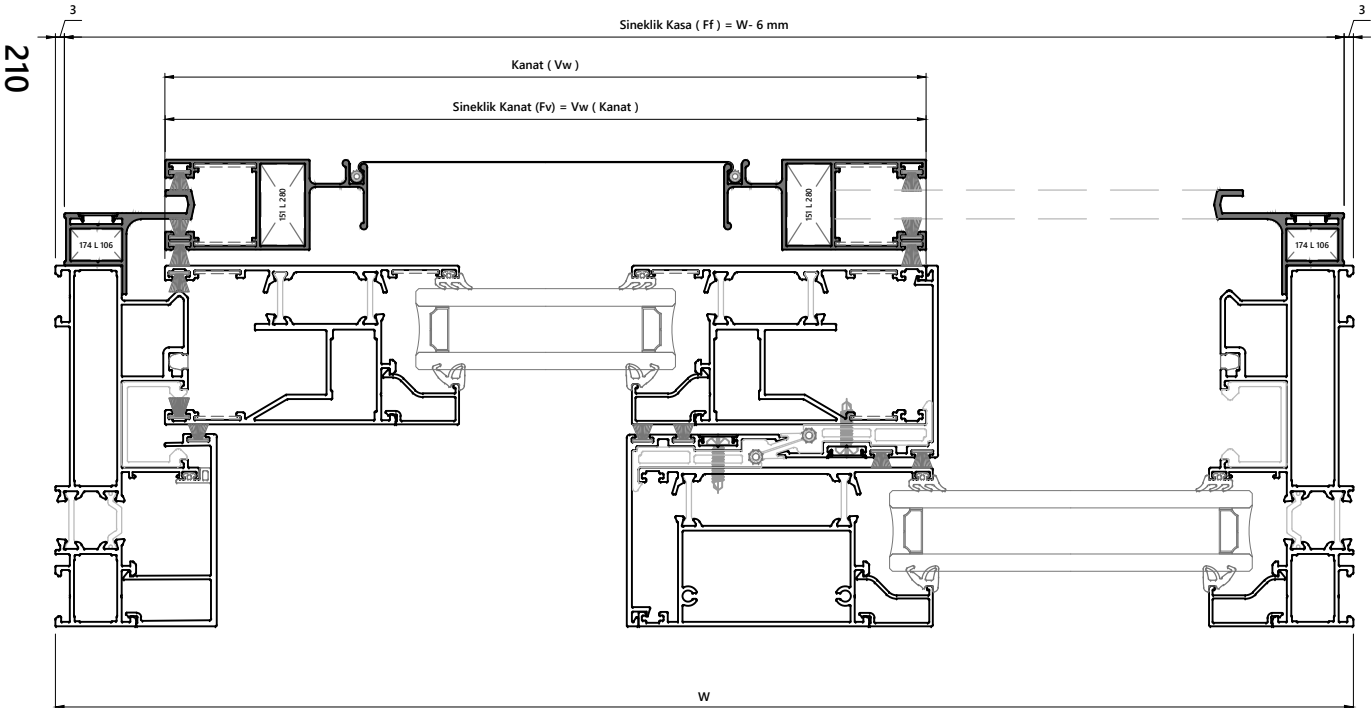
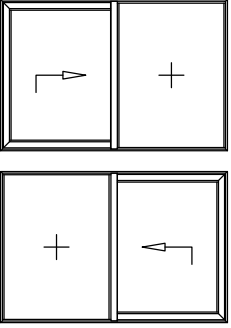

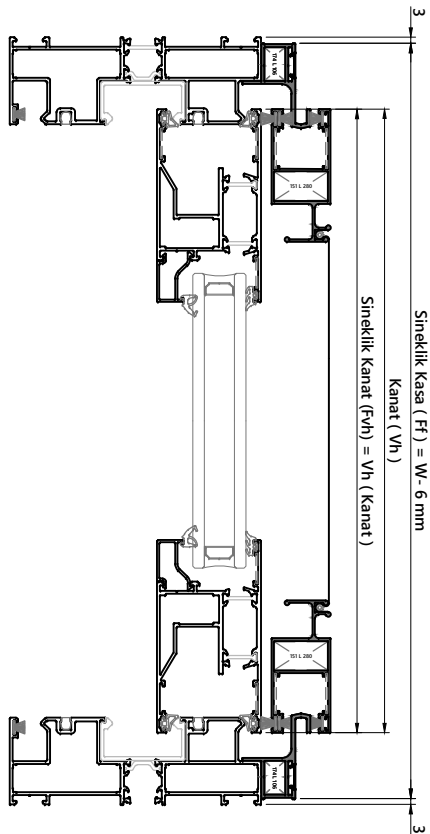

PROFİL KOD Profile Code	AÇIKLAMA Explanation	KESİM AÇISI Cut Angle	KESİM ÖLÇÜSÜ Cut Size	
			GENİŞLİK Weight	YÜKSEKLİK Height
S12502	Sineklik Kasa Profili	45° - 45°	W-6 mm	H - 6 mm
S12501	Sineklik Kanat Profili	45° - 45°	Vw	Vh
D12503	Vida Kapak Profili	45° - 45°	Ff-10 mm	

